



LABORATÓRIO NACIONAL  
DE ENGENHARIA CIVIL

DEPARTAMENTO DE ESTRUTURAS  
Núcleo de Engenharia Sísmica  
e Dinâmica de Estruturas

Proc. 0305/17/14529

## **PROJECT NEFOREEE – TASK 1**

### **Controlled Testing in the Non-Linear Range: Description of the Facility and Experimental Program**

Lisbon, February 2007

**I&D** ESTRUTURAS

**RELATÓRIO 25/2007 – NESDE/DE**



## **PROJECTO NEFOREEE – TASK 1**

### **Controlo de testes em presença de comportamentos não-lineares: Descrição das instalações e programa experimental**

O presente Relatório refere-se à Task 1 do Projecto NEFOREEE (New Fields of Research in Earthquake Engineering Experimentation) e compreende a descrição da plataforma sísmica triaxial do LNEC e o programa experimental desenvolvido no âmbito do Projecto em causa.

Apresenta-se a descrição da mesa sísmica com suporte gráfico, desenhos de dimensionamento e fotografias, bem como o seu sistema de controlo. Inclui-se ainda a instrumentação disponível no NESDE e a utilizada em particular para estes ensaios.

Descreve-se o modelo ensaiado, a sequência de ensaios e por fim apresentam-se os resultados obtidos. Para finalizar é feita uma breve análise de resultados.

Lisboa, Laboratório Nacional de Engenharia Civil, Fevereiro de 2007

## **NEFOREEE PROJECT – TASK 1**

### **Controlled testing in the non-linear Range: Description of the facility and experimental program**

This Report corresponds to Task 1 of the NEFOREEE (New Fields of Research in Earthquake Engineering Experimentation) Project and comprises the description of the LNEC triaxial seismic platform and a presentation of the experimental program developed in the scope of this Project.

It is presented a description of the facility and the 3D seismic table with graphical support, drawings of sizing and photographs, as well as its control system. The main instrumentation available at the NESDE laboratory and used for these tests is also included in this report.

The model tested is described as well as the sequence of tests and the obtained results. Finally a brief analysis of the results is made.

Lisbon, Laboratório Nacional de Engenharia Civil, February 2007



## TABLE OF CONTENTS

1. Introduction.....	1
2. Earthquake testing facility at LNEC.....	2
2.1. LNEC 3D SHAKING TABLE.....	2
2.2. INSTRUMENTATION.....	6
2.2.1. <i>Optical displacement transducers</i> .....	6
2.2.2. <i>Inductive displacement transducers – LVDTs</i> .....	6
2.2.3. <i>Accelerometers</i> .....	8
3. Description of the specimen tested.....	9
4. Instrumentation of the specimen and shaking tables.....	10
5. Experimental Program.....	11
5.1. INPUT SIGNAL.....	11
5.2. LOADING SEQUENCE.....	11
6. Data acquisition.....	12
7. Tests Results.....	13
8. Conclusions.....	14
9. Acknowledgements.....	14
10. References.....	14

### **ANNEX I - Details of the specimen - Photographic record**

### **ANNEX II - Shaking table tests: Input signals**

### **ANNEX III - Shaking table tests: Graphical presentation of the acquired data**

### **ANNEX IV - Preliminary results analysis**

## FIGURES INDEX

<b>Figure 1:</b> Bottom view of the LNEC-3D seismic platform.....	3
<b>Figure 2:</b> Transverse view. ....	3
<b>Figure 3:</b> Longitudinal view. ....	3
<b>Figure 4:</b> General plan of LNEC-3D shaking table. ....	4
<b>Figure 5:</b> Perspective of LNEC-3D shaking table.....	4
<b>Figure 6:</b> The optical spot position instrumentation unit (C5949 or C2399) using the semiconductor position sensing element (PSD).....	6
<b>Figure 7:</b> ACT Series Unguided LVDT Transducer (ACT2000C and ACT4000C). ....	7
<b>Figure 8:</b> ACT Series Unguided LVDT Transducer (ACT6000). ....	7
<b>Figure 9:</b> High frequency ENDEVCO, model 7290-A. ....	8
<b>Figure 10:</b> CROSSBOW LF series.....	8
<b>Figure 11:</b> PCB Piezotronics, model 337A26. ....	8
<b>Figure 12:</b> Front view of the model. ....	10
<b>Figure 13:</b> Lateral view of the model. ....	10
<b>Figure 14:</b> Instrumentation plan of the specimen and shaking table.....	11

## TABLE INDEX

<b>Table 1:</b> General Characteristics. ....	4
<b>Table 2:</b> Type of platform. ....	4
<b>Table 3:</b> Characteristics of the platform. ....	4
<b>Table 4:</b> Actuators. ....	4
<b>Table 5:</b> Platform performance. ....	5
<b>Table 6:</b> Characteristics of the control system. ....	5
<b>Table 7:</b> Characteristics of the analogic control. ....	5
<b>Table 8:</b> Characteristics of the digital control. ....	5
<b>Table 9:</b> Hydraulic system. ....	5
<b>Table 10:</b> Crane system inside the testing room. ....	5
<b>Table 11:</b> Access gates. ....	5
<b>Table 12:</b> Characteristics of the HAMAMATSU displacement transducers. ....	6
<b>Table 13:</b> Characteristics of the RDP displacements transducer. ....	7
<b>Table 14:</b> Characteristics of the HOTTINGER displacement transducer. ....	7
<b>Table 15:</b> Characteristics of the ENDEVCO accelerometers. ....	8
<b>Table 16:</b> Characteristics of the CROSSBOW LF accelerometers. ....	9
<b>Table 17:</b> Characteristics of the PCB accelerometers. ....	9
<b>Table 18:</b> Experimental program performed on LNEC-3D shaking table. ....	12
<b>Table 19:</b> List of channels used during the experimental program. ....	12
<b>Table 20:</b> Frequencies obtained during the experimental program. ....	13
<b>Table 21:</b> Required and achieved peak acceleration. ....	13





# 1. Introduction

This report provides a detailed account of a series of shaking table tests performed on a very specific specimen at the Portuguese National Laboratory of Civil Engineering (LNEC). The object of this research report corresponds to a part of TASK1 of NEFOREEE project (New Fields of Research in Earthquake Engineering Experimentation), named "Controlled Testing in the Non-Linear Range".

The main objectives of the NEFOREE Project are to pursue research in the following six areas of earthquake engineering:

1. Controlled testing in the non-linear range of material behaviour.
2. The complementarity of shaking tables and reaction walls.
3. Reliability of qualification tests performed on shaking tables.
4. Sub-structuring methods on shaking tables.
5. Multiple support input to large structures.
6. Continuous pseudodynamic (CPsD) testing with substructuring.

Each of the referred objectives corresponded to a determined Task, being LNEC involved in TASK 1 (Controlled Testing in the Non-Linear Range), and TASK 2 (Complementary Nature of Shaking Tables and Reaction Walls. For each one of the Tasks the lead partner was responsible for setting the objectives [1].

In what concerns the TASK1, the leadership was from the responsibility of CEA Saclay and the proposed research objectives were:

1. Test the large-scale model designed by the 3 partners and constructed in France. Two non-linear energy-absorbing devices will be used, together with a variety of inputs.
2. Carry out corroborating analysis of these tests, comparing linear with nonlinear behaviour.
3. Investigate what effect the previous results may have on Design Costs, particularly in EC8.
4. To transfer the model to LNEC Lisbon and LEE Athens for the same series of tests.

The test specimen was designed taking into account the different characteristics of each shaking table facility. The main characteristic of the specimen was the simulation of the global non-linear behaviour of a structure while being damaged during an earthquake. Besides that, the specimen had to be able to change its stiffness during the seismic tests in a controlled way, whenever wanted and during an adjustable duration.

Several tests were performed with the input motion to be scaled to achieve the required peak acceleration. During testing, the stiffness of the specimen was decreased, 5 seconds after the signal has been started by slow or fast discharge of pressure air.

These tests were performed in LNEC shaking table during the beginning of January 2005 and were carried out in the transverse direction of the shaking table.

## **2. Earthquake testing facility at LNEC**

The 3D shaking table together with a uniaxial shaking table are placed in the Earthquake Engineering Research Centre (NESDE), a LNEC division devoted to the research in the area of Earthquake Engineering. The research is being developed in NESDE in the past years addressing subjects from the seismic experimental and analytical modeling of structural systems to the issues of the seismic hazard and risk analysis [2].

LNEC seismic facility operates since 1996 and has been integrated in the “Large Scale Scientific Installations” of the European Union since its beginning. The equipment is operated by LNEC personnel. Besides the shaking tables and their power stations, this infrastructure includes specifically dedicated rooms devoted to control, data acquisition and processing.

The use of LNEC seismic testing facility by external users has been providing significant information and important outcomes for the improvement of knowledge on the seismic response of different types of structures. The equipment and the methodologies of testing have to be frequently improved, aiming at the continuous improvement of the service provided and the increase of the field of application of the facility.

The interest of the studies performed within the use of this facility has been clearly demonstrated by the results of several large experimental studies carried out within the European funded ECOEST and ECOLEADER networks that enabled, in the framework of the Large Scale Facilities and Access to Research Infrastructures sub-programmes of TMR and IHP Programmes, the access of numerous foreign researchers to the LNEC facility and allowed the study of several key issues in Earthquake Engineering Research.

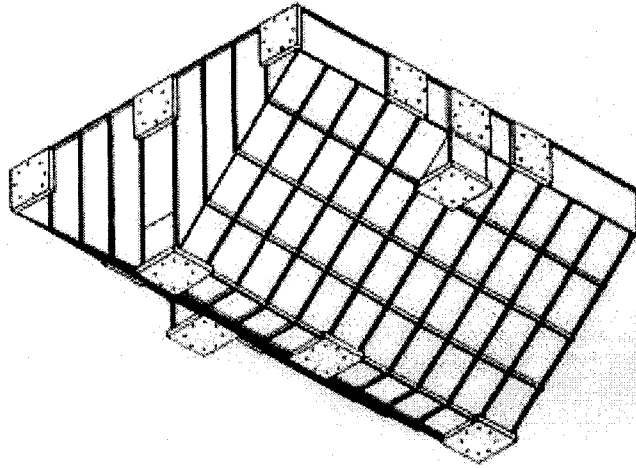
LNEC international standing has already attracted a widespread of interested scientific groups, clearly demonstrated by the quality of previous users and also by the interest shown by potential future users. It should be mentioned that LNEC 3D shaking table has unique features, which justify that some experimental research activities can only be performed in this facility.

On the National scale, LNEC holds a leading position in the fields of seismic testing and earthquake risk assessment. NESDE/LNEC has developed important activity in the framework definition of seismic scenarios for the Metropolitan Area of Lisbon (MAL) by the request of the National Civil Protection.

### **2.1. LNEC 3D Shaking table**

The LNEC3-D shaking table is constituted by three main subgroups: (1) the body (or platform), on which the models or specimens are attached and tested; (2) the guidance system, whose main mission consists of ensuring that the platform only moves according to desired degrees of freedom; and (3) the actuating system, which includes the control systems associates and that has for mission to impose the desired action during the experimental programs [3].

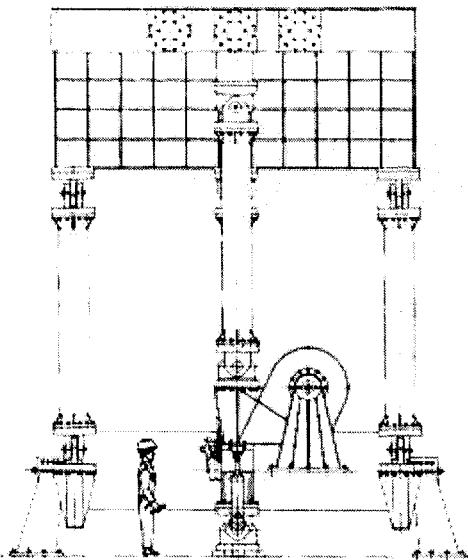
The platform is a structure in welded steel plates with a triangular prism form, with the corresponding useful dimensions of 4,6x5,6 m<sup>2</sup> where are mounted and fixed, the models or specimens to be tested during the experimental programs developed in LNEC. The structure of the platform was conceived in order to present high local and global rigidity in the connection areas with the remaining subgroups of the main structure (as the actuating and guidance systems).



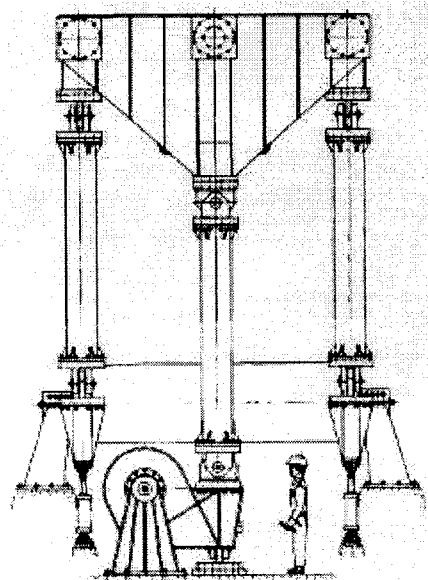
**Figure 1:** Bottom view of the LNEC-3D seismic platform.

The guidance system constitutes an innovative element when compared to other seismic platforms. In the seismic tests carried out in LNEC 3D seismic platform the global movement of the body will be result of the combination of three translation movements (two horizontal and a vertical one). These translations correspond to the three of the six degrees of freedom of the body of the platform. In this context, the guidance system will have to eliminate (or, in the reality, adequately to restrict) the possibility of the movement of the body according to these three remaining degrees of freedom, that, as it is known, are constituted by rotations around the three orthogonal.

The experience achieved with the seismic platform shows that the performance is not away from what was expect in the design.



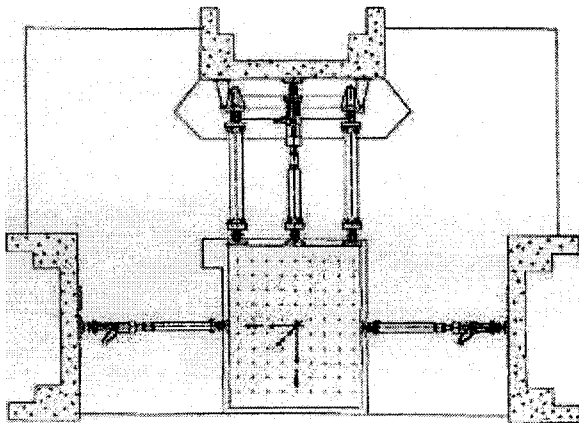
**Figure 2:** Transverse view.



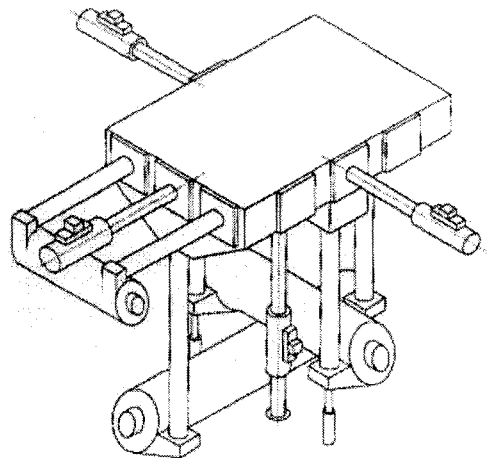
**Figure 3:** Longitudinal view.

The actuating system is essentially constituted by oil-hydrmechanical actuators and associated control systems. In a simplified way each actuator is constituted of an hydraulic cylinder of double-effect and pair-connecting rod, one or more servovalves and a set of hydraulic components, responsible for linking, command and security. The oil under pressure (normal

pressure of functioning 200 bar) is supplied by a group of hydraulical motion-bombs with a maximum debit of 690 liters/min [adapted from 2].



**Figure 4:** General plan of LNEC-3D shaking table.



**Figure 5:** Perspective of LNEC-3D shaking table.

In the following tables are resumed the main characteristics of LNEC – 3D shaking table:

**Table 1:** General Characteristics.

General Designation	MESA SÍSMICA TRIAXIAL DO LNEC
Short Designation	LNEC-3G
Design/Construction	LNEC e INSTRON
Year	1995

**Table 2:** Type of platform.

	Longitudinal X	Lateral Y	Vertical Z	Rotation X	Rotation Y	Rotation Z
Multiaxial	Yes	Yes	Yes	N/A	N/A	N/A

**Table 3:** Characteristics of the platform.

Dimensions (mxm)	4.6x5.6
Weight (kN)	392
Material	Steel

**Table 4:** Actuators.

	Hydraulic actuators		
	Manufacturer	Force (kN)	Units
Longitudinal	INSTRON	1250	1
Lateral	INSTRON	750	2
Vertical	INSTRON	375	1

**Table 5:** Platform performance.

Frequencies			Hz	0.1/40.0
Max efective course	Horizontal		mm	290/400
	Vertical		mm	290/400
Max velocity (nominal)	Horizontal	Transverse	cm/s	70.1/121.5
		Longitudinal	cm/s	41.9/72.6
	Vertical		cm/s	42.4/73.5
Max acceleration (platform without model)	Horizontal	Transverse	m/s <sup>2</sup>	18.75
		Longitudinal	m/s <sup>2</sup>	9.38
	Vertical		m/s <sup>2</sup>	31.25
Max self-weight of the model			kN	392
Max compensated self-weight			kN	392

**Table 6:** Characteristics of the control system.

Type of control	Compound (Analogic/Digital)
-----------------	-----------------------------

**Table 7:** Characteristics of the analogic control.

Manufacturer	INSTRON
Type	Uni-Variable units

**Table 8:** Characteristics of the digital control.

Hardware	Industrial Computer	INSTRON 8580 Control Tower
	Channels D/A	8 ADC channels – 16 bit
	Channels A/D	
Software	Design	INSTRON

In the testing room, where is placed the seismic platform, there are some additional structures that are described in the following tables

**Table 9:** Hydraulic system.

Electric Power (kW)	330
Flow Rate (kN)	690
Pressure (MPa)	20.7

**Table 10:** Crane system inside the testing room.

Number of cranes	2
Maximum capacity (kN)	392
Maximum height (m)	8

**Table 11:** Access gates.

Number of gates	2
Maximum height (m)	4.5

## 2.2. Instrumentation

### 2.2.1. Optical displacement transducers

Optical displacement transducers HAMAMATSU C5949 (comprising F50 mm lens, sensor head and led target) and HAMAMATSU conditioning device PSH Controllers C2399 can be used for measuring the displacements on the vertical/transverse plane. The following figure and table show the type of HAMAMATSUs used in LNEC-3D shaking table experimental programs and their main characteristics.



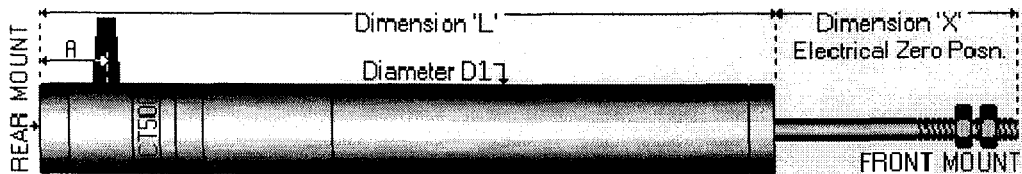
**Figure 6:** The optical spot position instrumentation unit (C5949 or C2399) using the semiconductor position sensing element (PSD).

**Table 12:** Characteristics of the Hamamatsu displacement transducers.

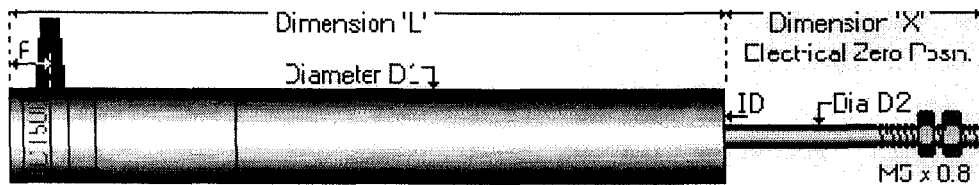
Manufacture	HAMAMATSU PHOTONICS ( <a href="http://www.hamamatsu.com">www.hamamatsu.com</a> )
Model	C2399-00 and C5949
Measurement points	1 to 7
Spectral response	700 to 1150 nm
Sampling frequency	300 Hz
Position detecting error	+/-1
Error due to lighth	+/-1

### 2.2.2. Inductive displacement transducers – LVDTs

RDP Electronics ACT/2000C, ACT4000C and ACT6000 inductive displacement transducers having work strokes of +/-50mm, +/-100mm and +/-150mm, respectively, can be used for measuring vertical and diagonal displacements. Figures 7 and 8 show the general aspect of the inductive displacement transducers used for the instrumentation in LNEC facility.



**Figure 7:** ACT Series Unguided LVDT Transducer (ACT2000C and ACT4000C).



**Figure 8:** ACT Series Unguided LVDT Transducer (ACT6000).

The following tables show some of the main characteristics of the LVDT displacement transducers that can be used during the tests performed in LNEC shaking table.

**Table 13:** Characteristics of the RDP displacements transducer.

Manufacture	RDP ELECTRONICS ( <a href="http://www.rdpe.com">www.rdpe.com</a> )
Model	ACT2000, ACT4000 and ACT6000
Stroke	+/-50mm (ACT2000); +/-100mm (ACT4000); +/-150mm (ACT6000)
Sensitivity	15mV/V/mm (ACT6000) to 3030mV/V/mm (ACT2000)
Energising supply	5 Vrms, 5 Hz
Linearity deviation	0.08% (ACT2000) to 0,3% (ACT6000)

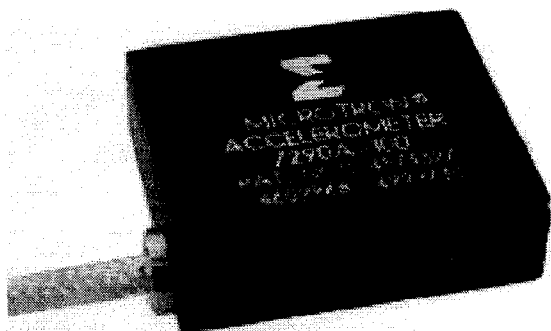
Besides the RDP Electronics, and for displacement measurements, are also available in LNEC facility inductive displacement transducers from the type HOTTINGER BALDWIN M. Their main characteristics are presented in the following table.

**Table 14:** Characteristics of the Hottinger displacement transducer.

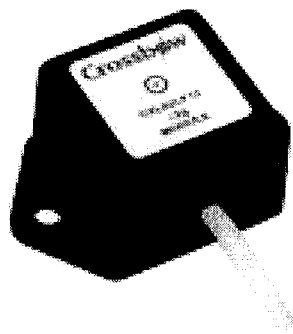
Manufacture	HOTTINGER BALDWIN M ( <a href="http://www.hbm.com">www.hbm.com</a> )
Model	WA300 and WA500
Sensitivity	80mV/V
Linear deviation	700 to 1150 nm
Sampling frequency	+/-0.1% to +/-0.2%
Frequency range	5 to 65 Hz

### 2.2.3. Accelerometers

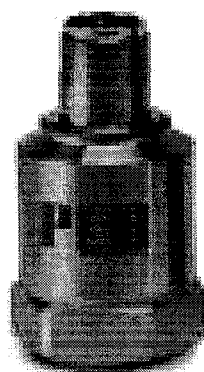
High frequency ENDEVCO, model 7290-A with variable capacitance, CROSSBOW LF series with high precision and PCB Piezotronics, model 337A26, can be used for acceleration measurements in the experimental programs in development in LNEC facility. Figures 9, 10 and 11 show the general aspect of the referred accelerometers.



**Figure 9:** High frequency ENDEVCO, model 7290-A.



**Figure 10:** CROSSBOW LF series.



**Figure 11:** PCB Piezotronics, model 337A26.

The following tables show some of the main characteristics of the accelerometers existing in LNEC facility.

**Table 15:** Characteristics of the ENDEVCO accelerometers.

Manufacture	MEGGITT SENSORS ( <a href="http://www.endevco.com">www.endevco.com</a> )
Model	7290A-2 and 7290A-10
Range [g pk]	+/-2 and +/-10
Sensitivity (at 100Hz) [mV/g]	1000+/-20 and 200+/-10
Amplitude Response +/-5% [Hz]	0 to 15 and 0 to 500
Mounted Resonance and frequency [Hz]	1300 and 3000
Transverse Sensitivity [% Max]	2
Zero Measurand Output [mV Max]	+/-50
Damping Ratio [-]	4.5 and 0.7



**Table 16:** Characteristics of the CROSSBOW LF accelerometers.

Manufacture	CROSSBOW ( <a href="http://www.xbow.com">www.xbow.com</a> )
Model	CXL02LF3
Input Range [g pk]	+/-2
Sensitivity [V/g]	1
Transverse Sensitivity [%FS]	+/-5
Non-Linearity [%FS]	+/-2
Alignment Error [deg]	+/-2
Noise Density [ $\mu\text{g}/\text{Hz}^{1/2}$ ]	140
Noise [mg rms]	1
Bandwidth [Hz]	DC-50

**Table 17:** Characteristics of the PCB accelerometers.

Manufacture	PCB PIEZOTRONICS ( <a href="http://www.pcb.com">www.pcb.com</a> )
Model	337A26
Sensitivity [mV/g]	100
Measurement range [g pk]	100
Broadband resolution [g rms]	0.0001
Frequency range [Hz]	0.5 to 5000

### 3. Description of the specimen tested

In general the specimen tested is composed by: a) footing plate which allows the perfect connection to CEA, LNEC and NTUA shaking tables, b) rigid steel frame, c) oscillation mass attached with more or less rigidity to the steel frame and corresponding to an initial excitation frequency of about 7Hz, d) system of four pressurized airbags which allows the modification of the frequency during any seismic test. In Figures 12 and 13 are presented, respectively, the front and the lateral view of the model.

The oscillation mass, above referred, is characterized by its stiffness and its damping, which roughly allows the simulation of the response of a model equivalent to a building. The main characteristics are able to change in a controlled way, whenever wanted and during an adjustable duration, in order to simulate the degradation due to seismic inputs. The mobile mass of the specimen corresponds to an important percentage of the shaking tables masses, particularly for the smallest table considered (NTUA) for which corresponds to 70%. The mass, composed by a set of several identical plates has a maximum of 7ton and allows the use of a smaller number of plates if convenient. Transversely the mass is guided in order not to disturb the longitudinal motion during the tests. Vertically the mass is maintained by a bearing device that was designed to have a vertical frequency higher than 20Hz [4].



**Figure 12:** Front view of the model.

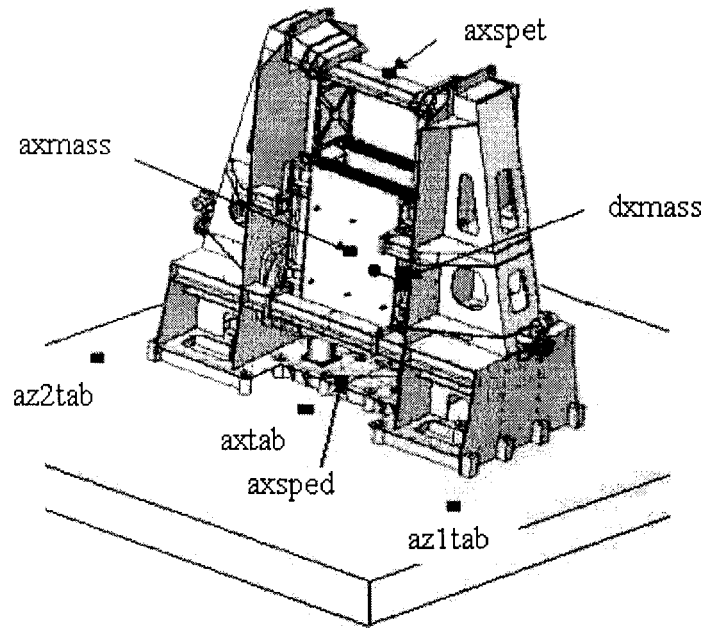


**Figure 13:** Lateral view of the model.

The frequency was able to be adjusted by the air bags pressures and the damping was ensured by a set of Gerb shock absorbers. The changing of frequency, from about 7Hz to 3Hz during the tests, was obtained by a partial depressurization through specific gauged diaphragms. Two diaphragms of larger (60mm) and smaller (10mm) openings were tested for validation of the discharges duration.

#### **4. Instrumentation of the specimen and shaking tables**

The instrumentation on the table and on the specimen consisted only in one displacement transducer to measure the displacement of the additional masses, one optical transducer to measure two displacements on the table and five accelerometers to measure the accelerations on the bottom and top of the specimen, on the centre of the additional masses and at two different points of the shaking table platform to check the level of rotations that were generated. In Figure 14 is presented the instrumentation plan of the specimen and of the shaking table proposed for the NEFOREE – Task 1 Project. In what concerns the LNEC experimental program the accelerometers az2tab, az1tab and axtab were not used.



**Figure 14:** Instrumentation plan of the specimen and shaking table.

The different input signals and the condition of the valves were also recorded: a) velocity, force and displacement of the table, b) displacement and force from roll and pitch degrees of freedom, c) displacement, intensity and delta pressure on the level of a servo valve of one actuator, d) driver signal sent to the servo valve, e) opening and closing commands of the valves and e) opening and closing response of the valves.

## 5. Experimental Program

### 5.1. Input signal

Preliminary tests have been performed to calibrate the pressure in each pair of airbags to obtain the required frequencies. With the referred pressurized airbags the frequency of the moving mass is 6.7Hz while without pressure the minimum frequency measured was 3.4Hz.

The base signal was filtered for a frequency band ranging from 0.1 to 33 Hz and adapted to achieve a table acceleration of 0.6g. During the tests this signal was scaled to achieve the desired peak acceleration level. In all tests the trigger action to open the relief valves has occurred 5s after the start of the input signal. The slow discharges (approximately 5s) were obtained by using a diaphragm with a 10mm opening; while the fast discharges (approximately 0.1 s) were obtained by using a diaphragm with a 60 mm opening.

### 5.2. Loading sequence

A common sequence of tests was proposed for the three shaking tables (CEA, LNEC and NTUA) under the NEFOREEE Project. In LNEC were also performed some additional tests. Next table resumes the experimental program performed at LNEC

**Table 18:** Experimental program performed on LNEC-3D shaking table.

PGA [g]	Description
<b>0.1</b>	<b>Test 1</b> - without discharge
	<b>Test 2</b> - with a 5 seconds discharge (10mm diaphragm)
	<b>Test 3</b> - with a 0.1 seconds discharge (60mm diaphragm)
<b>0.4</b>	<b>Test 4</b> - without discharge
	<b>Test 5</b> - with a 5 seconds discharge (10mm diaphragm)
	<b>Test 6</b> - with a 0.1 seconds discharge (60mm diaphragm)
<b>0.6</b>	<b>Test 7</b> - without discharge
	<b>Test 8</b> - with a 5 seconds discharge (10mm diaphragm)
	<b>Test 9</b> - with a 0.1 seconds discharge (60mm diaphragm)
<b>0.8</b>	<b>Test 10</b> - without discharge
	<b>Test 11</b> - with a 5 seconds discharge (10mm diaphragm)
	<b>Test 12</b> - with a 0.1 seconds discharge (60mm diaphragm)
<b>1.0</b>	<b>Test 13</b> - with a 0.1 seconds discharge (60mm diaphragm)
<b>1.2</b>	<b>Test 14</b> - with a 0.1 seconds discharge (60mm diaphragm)

## 6. Data acquisition

The model tested was instrumented with accelerometers and inductive displacement transducers (LVDTs) similar to the ones already referred. The corresponding physical units used all along the present Report are g and mm, respectively. The shaking table acceleration and displacement were recorded during the experimental program. The list of channels, with the corresponding identification numbers and simplified description of the measurement parameters, is following presented.

**Table 19:** List of channels used during the experimental program.

Channel	Identification
0	Acceleration in shaking table (EW)
1	Acceleration in shaking table (NS)
2	Acceleration in A1 (EW-bottom)
3	Acceleration in A2 (NS-bottom)
4	Air Bag Pressure Trigger
5	Acceleration in A4 (EW-Mass)
6	Acceleration in A5 (NS-Mass)
7	Acceleration in A6 (Vert-Mass)
8	Acceleration in A7 (EW-Top)
9	Acceleration in A8 (NS-Top)
10	Acceleration in A9 (Vert-Top)
11	Displacement in D1 (Mass)
12	Displacement D2 in shaking table (EW)
13	Displacement D3 in shaking table (NS)

## 7. Tests Results

The frequencies of the specimen were obtained by means of the FRFs for each on of the tests. The values obtained are summarized in the following table and graphically presented in Annex IV.

**Table 20:** Frequencies obtained during the experimental program.

Test	Frequency of specimen [Hz]
1	6.65
2	7.02
3	7.02
4	6.53
5	6.41
6	6.53
7	6.71
8	6.30
9	6.53
10	6.41
11	6.35
12	6.47
13	6.53
14	6.53

During discharge tests, the change of the frequency of the tests specimen was always triggered 5 seconds from the beginning of the seismic time history. In the case of slow discharge, the change of the frequency of the specimen took place within 5 seconds, while in the case of fast discharge the change of the frequency happened within 0.10 seconds. More detailed results are presented in Annex IV.

For each test, the acceleration time histories (Annex III) and the corresponding response spectrum are plotted, as well as the hysteretic loops of the force-displacement relations (Annex IV) in which may be observed the stiffness reduction from the situations without discharge to the situations with discharge. The comparison between required and achieved peak accelerations is presented in Table 23.

**Table 21:** Required and achieved peak acceleration.

Test	Required peak acceleration [g]	Achieved peak acceleration [g]	Difference [%]
1	0.1	0.082	-18.00
2	0.1	0.096	-4.00
3	0.1	0.098	-2.00
4	0.4	0.396	-1.00
5	0.4	0.386	-3.50
6	0.4	0.392	-2.00
7	0.6	0.563	-6.17
8	0.6	0.548	-8.67
9	0.6	0.555	-7.50
10	0.8	0.861	7.63
11	0.8	0.865	8.13
12	0.8	0.861	7.63
13	1.0	1.152	15.02
14	1.2	1.297	8.08

The comparison between the acceleration series for each one of the different PGA steps (0.1, 0.4, 0.6 and 0.8) is also presented in Annex IV. The differences observed correspond to the performance of the table for the different steps of the experimental program and considering the different discharges.

## 8. Conclusions

The tests carried out on the LNEC shaking table, and the analysis of their results, showed that the control of the LNEC 3D shaking table was not affected by the fast decrease of stiffness of the mock-up. It should be mentioned that the mass of the specimen tested was relatively small when compared with the mass of the shaking table (40 ton).

Comparing the achieved and desired time histories of input motion (Annex II) and the relevant response spectra (Annex IV) for all the performed tests it can be concluded that the tests performed in LNEC have demonstrated an excellent performance achieved by the control system of the shaking table during the performance of the tests. In both cases (slow or fast changes) the frequency of the response did not show a significant difference.

The stiff reduction observed was larger for fast discharges. It was also observed the increasing of the force in the mass during the tests as well as the measured displacements, as expected.

## 9. Acknowledgements

The studies described in the present paper were financed by the European Union (contract HPRI-CT-2001-50023) under the NEFOREEE Project (New Fields of Research in Earthquake Engineering Experimentation) in the aim of the “Specific Research and Technological Development Programme” of the “Human Research Potential and Socio-Economic Knowledge Base”.

The cooperation of LNEC personnel, namely Eng<sup>o</sup> Campos Costa, Eng<sup>o</sup> Paulo Morais, Artur Santos, Ana Marques, Paulo Semedo and Dulcina Marecos, during the preparation and the performance of the shaking table tests, was deeply appreciated.

The authors wish to thank also Ana Marques, for her careful help concerning the tables and figures preparation and the word processing of this report.

## 10. References

- [1] New Fields of Research in Earthquake Engineering Experimentation (NEFOREEE) – Third Annual Report on RTD CONTRACT HPRI – CT – 2001 – 50023
- [2] Coelho, E., Campos Costa, A., Experimental Earthquake Engineering Research in LNEC, LNEC divulgation brochure, 2005.
- [3] Emílio, F.T., Duarte, R.T., Carvalhal, F.J., Costa, C.O., Vaz, C.T., Corrrêa, M.R., The new LNEC shaking table for earthquake resistance testing, Memoire LNEC 757, 1989.
- [4] Bairrão, R. Falcão Silva, M.J., Carydis, P., Mouzakis, H., Karapitta, L., Quéval, J.C., NEFOREEE: Performance benchmark of three major European shaking tables, 1<sup>st</sup> European Conference on Earthquake Engineering and Seismology, paper 110, Geneve, Switzerland, 2006.

VISTOS

A Chefe do Núcleo de Engenharia Sísmica e  
Dinâmica de Estruturas



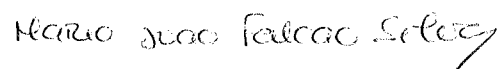
Ema Coelho

O Director  
do Departamento de Estruturas



João Almeida Fernandes

AUTORIA



Maria João Falcão Silva  
Bolsista de Doutoramento



Rogério Bairrão  
Investigador Principal

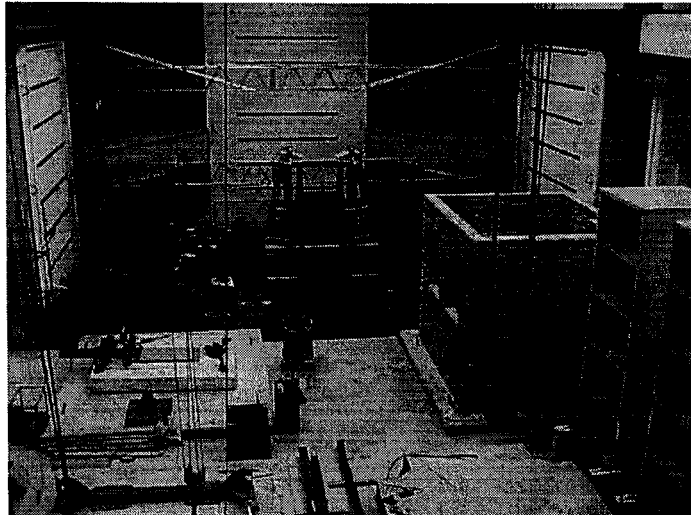




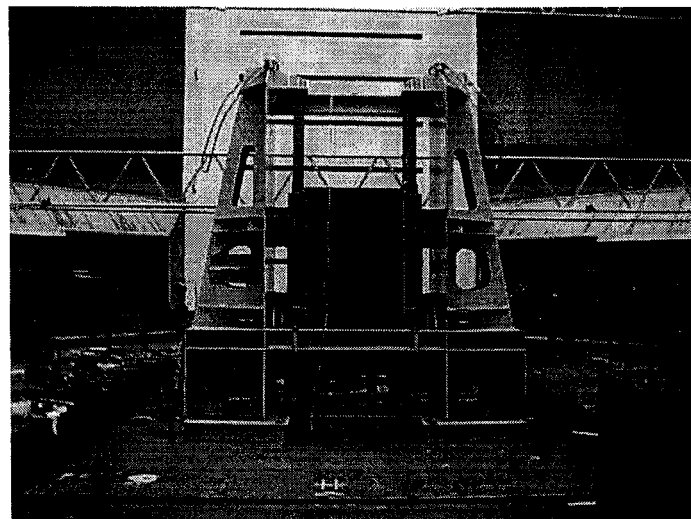
## FIGURES INDEX

<b>Figure 1:</b> General view of the LNEC facility with the NEFOREEE specimen on the 3D-shaking table. ....	1
<b>Figure 2:</b> NEFOREEE specimen before the experimental program (front view). ....	1
<b>Figure 3:</b> NEFOREEE specimen before the experimental program (side view). ....	1
<b>Figure 4:</b> Details on the instrumentation of the NEFOREEE specimen (axsped). ....	2
<b>Figure 5:</b> Details on the instrumentation of the NEFOREEE specimen (dxmass). ....	2
<b>Figure 6:</b> Details on the instrumentation of the NEFOREEE specimen (axmass). ....	2

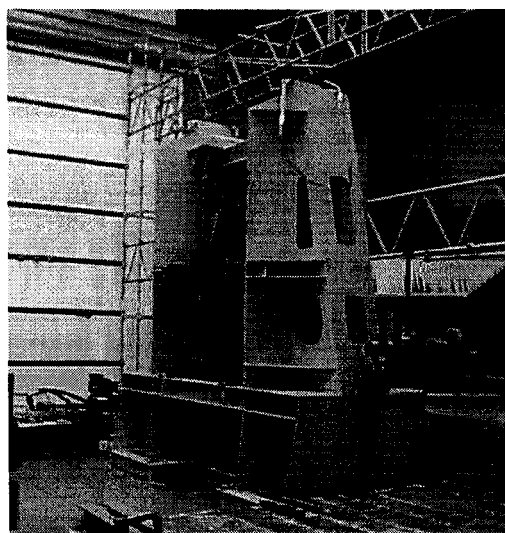




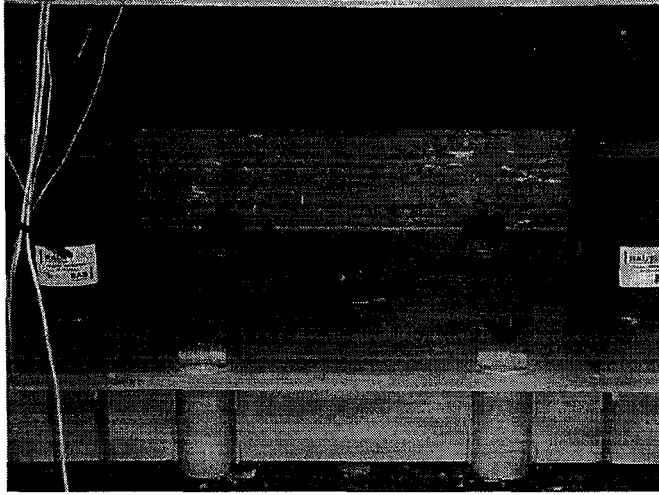
**Figure 1:** General view of the LNEC facility with the NEFOREEE specimen on the 3D-shaking table.



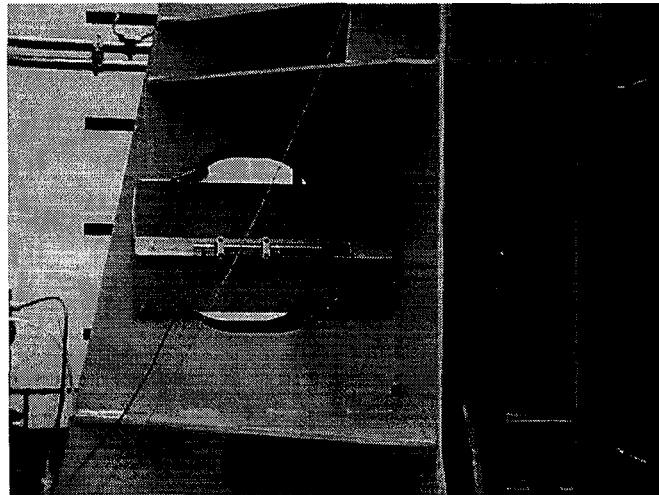
**Figure 2:** NEFOREEE specimen before the experimental program (front view).



**Figure 3:** NEFOREEE specimen before the experimental program (side view).



**Figure 4:** Details on the instrumentation of the NEFOREEE specimen (axsped).



**Figure 5:** Details on the instrumentation of the NEFOREEE specimen (dxmass).



**Figure 6:** Details on the instrumentation of the NEFOREEE specimen (axmass).

## **ANNEX II – Shaking table tests: Input signals**

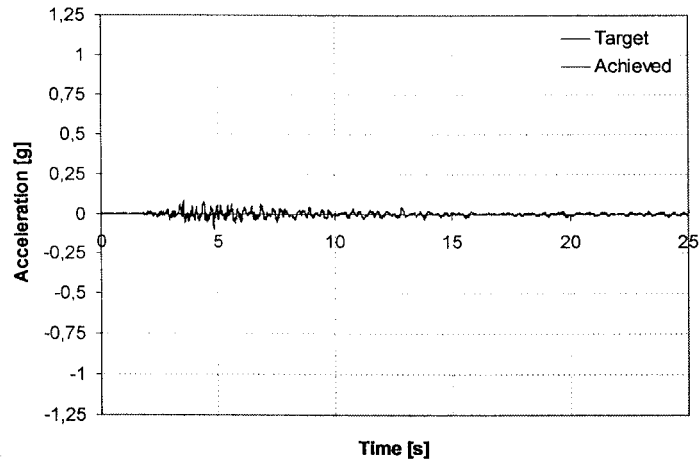


## FIGURES INDEX

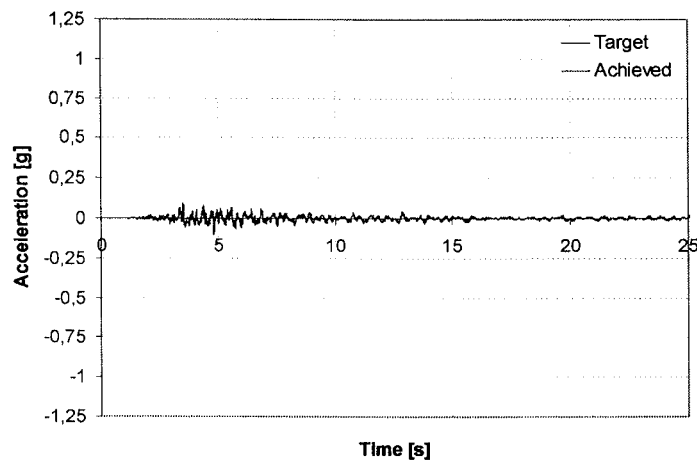
<b>Figure 1:</b> Target and achieved time histories in EW direction (Test 1).....	1
<b>Figure 2:</b> Target and achieved time histories in EW direction (Test 2).....	1
<b>Figure 3:</b> Target and achieved time histories in EW direction (Test 3).....	1
<b>Figure 4:</b> Target and achieved time histories in EW direction (Test 4).....	2
<b>Figure 5:</b> Target and achieved time histories in EW direction (Test 5).....	2
<b>Figure 6:</b> Target and achieved time histories in EW direction (Test 6).....	2
<b>Figure 7:</b> Target and achieved time histories in EW direction (Test 7).....	3
<b>Figure 8:</b> Target and achieved time histories in EW direction (Test 8).....	3
<b>Figure 9:</b> Target and achieved time histories in EW direction (Test 9).....	3
<b>Figure 10:</b> Target and achieved time histories in EW direction (Test 10).....	4
<b>Figure 11:</b> Target and achieved time histories in EW direction (Test 11).....	4
<b>Figure 12:</b> Target and achieved time histories in EW direction (Test 12).....	4
<b>Figure 13:</b> Target and achieved time histories in EW direction (Test 13).....	5
<b>Figure 14:</b> Target and achieved time histories in EW direction (Test 14).....	5



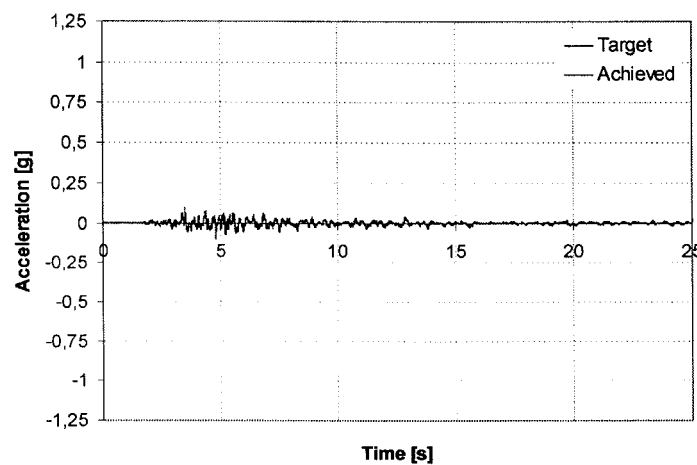




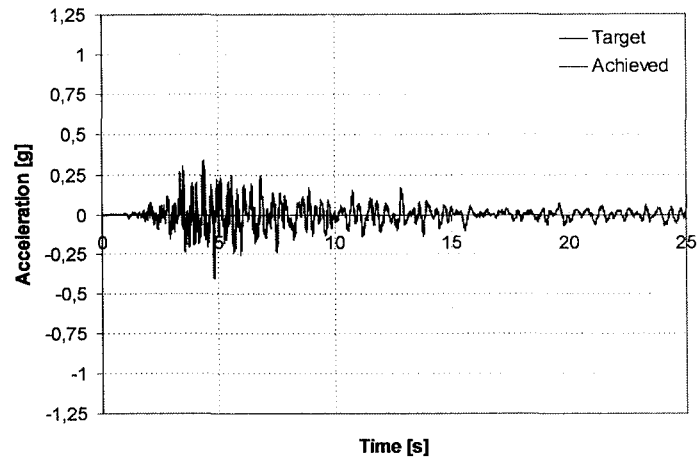
**Figure 1:** Target and achieved time histories in EW direction (Test 1).



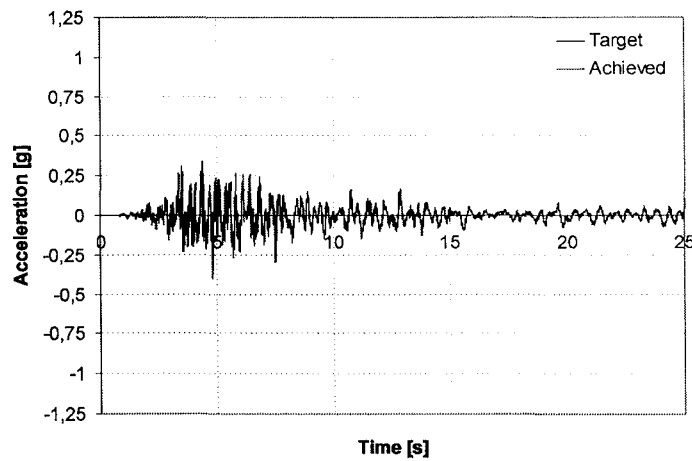
**Figure 2:** Target and achieved time histories in EW direction (Test 2).



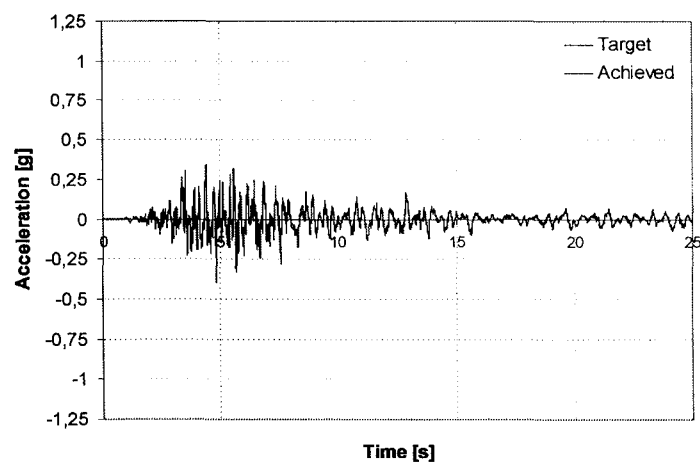
**Figure 3:** Target and achieved time histories in EW direction (Test 3).



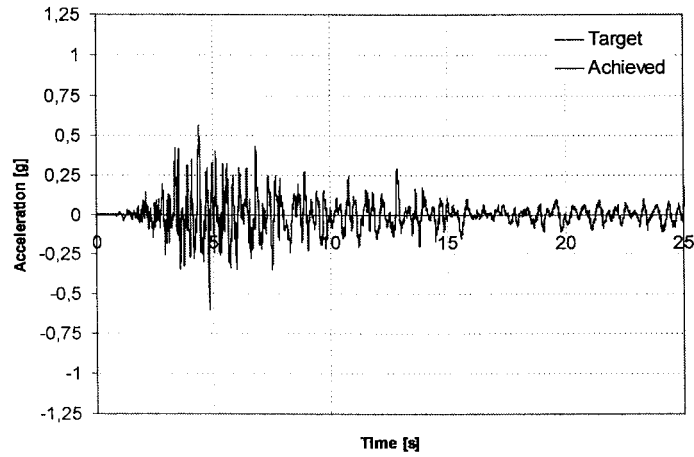
**Figure 4:** Target and achieved time histories in EW direction (Test 4).



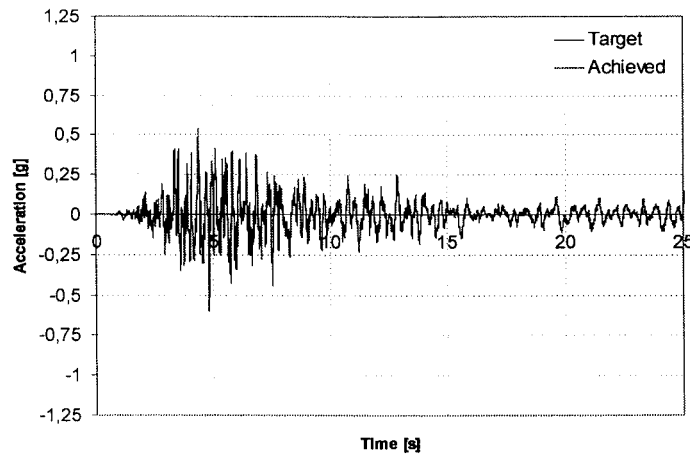
**Figure 5:** Target and achieved time histories in EW direction (Test 5).



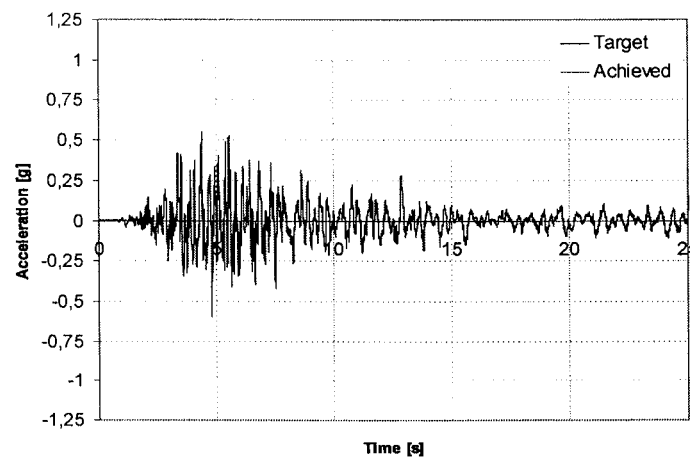
**Figure 6:** Target and achieved time histories in EW direction (Test 6).



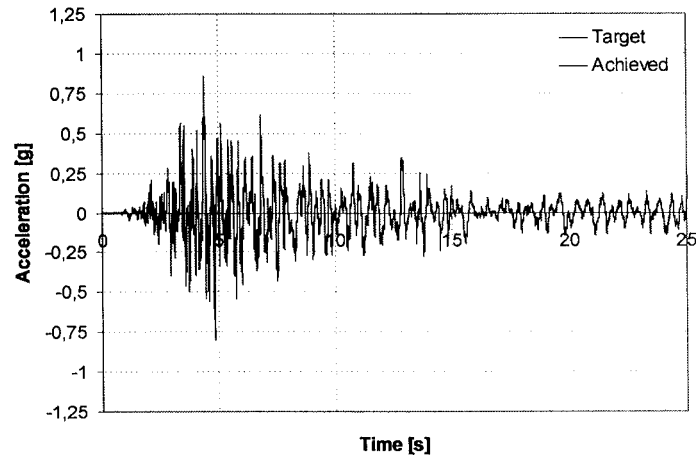
**Figure 7:** Target and achieved time histories in EW direction (Test 7).



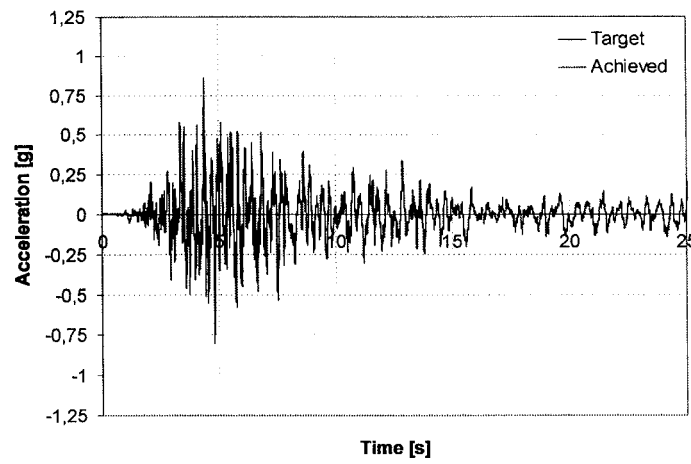
**Figure 8:** Target and achieved time histories in EW direction (Test 8).



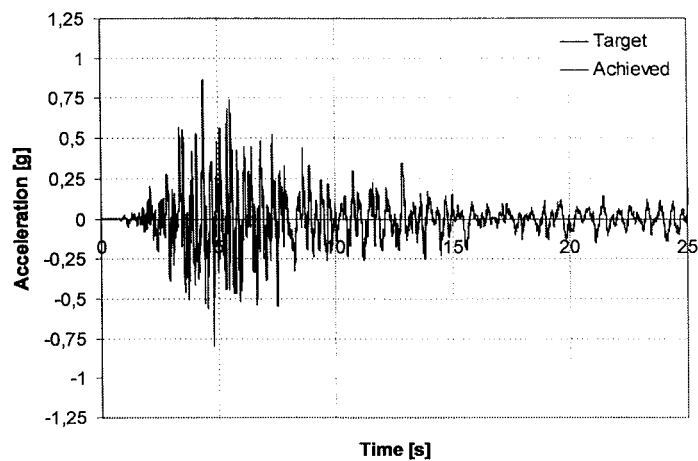
**Figure 9:** Target and achieved time histories in EW direction (Test 9).



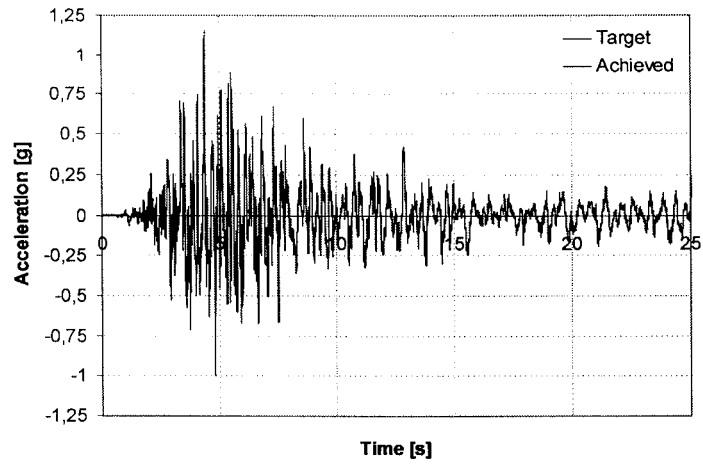
**Figure 10:** Target and achieved time histories in EW direction (Test 10).



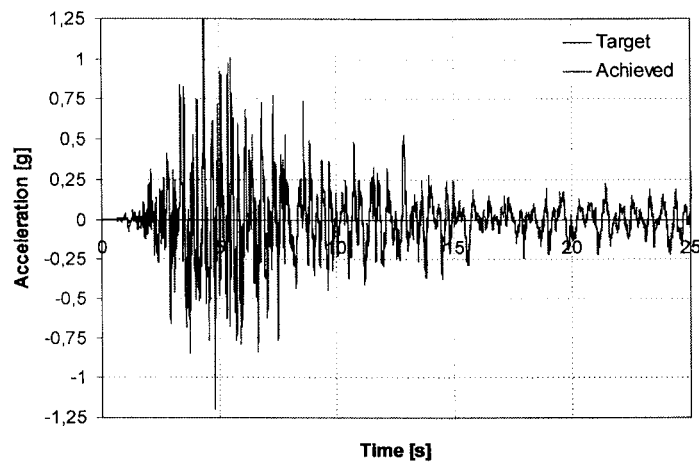
**Figure 11:** Target and achieved time histories in EW direction (Test 11).



**Figure 12:** Target and achieved time histories in EW direction (Test 12).



**Figure 13:** Target and achieved time histories in EW direction (Test 13).



**Figure 14:** Target and achieved time histories in EW direction (Test 14).



**ANNEX III – Shaking table tests: Graphical presentation of the acquired data**





## FIGURES INDEX

### Test 1 – PGA=0.1g without discharge

<b>Figure 1:</b> EW acceleration in shaking table.....	3
<b>Figure 2:</b> NS acceleration in shaking table.....	3
<b>Figure 3:</b> Bottom EW acceleration (A1).....	3
<b>Figure 4:</b> Bottom NS Acceleration (A2).....	4
<b>Figure 5:</b> Air Bag Pressure Trigger. ....	4
<b>Figure 6:</b> Mass EW acceleration (A4). ....	4
<b>Figure 7:</b> Mass NS acceleration (A5). ....	5
<b>Figure 8:</b> Mass vertical acceleration (A6).....	5
<b>Figure 9:</b> Top EW acceleration (A7).....	5
<b>Figure 10:</b> Top NS acceleration (A8). ....	6
<b>Figure 11:</b> Top vertical acceleration (A9). ....	6
<b>Figure 12:</b> Mass displacement (D1). ....	6
<b>Figure 13:</b> EW displacement in shaking table (D2). ....	7
<b>Figure 14:</b> NS Displacement in shaking table (D3).....	7

### Test 2 - PGA=0.1g with a 5 seconds discharge

<b>Figure 15:</b> EW acceleration in shaking table.....	11
<b>Figure 16:</b> NS acceleration in shaking table.....	11
<b>Figure 17:</b> Bottom EW acceleration (A1).....	11
<b>Figure 18:</b> Bottom NS Acceleration (A2).....	12
<b>Figure 19:</b> Air Bag Pressure Trigger. ....	12
<b>Figure 20:</b> Mass EW acceleration (A4). ....	12
<b>Figure 21:</b> Mass NS acceleration (A5). ....	13
<b>Figure 22:</b> Mass vertical acceleration (A6).....	13
<b>Figure 23:</b> Top EW acceleration (A7).....	13
<b>Figure 24:</b> Top NS acceleration (A8). ....	14
<b>Figure 25:</b> Top vertical acceleration (A9). ....	14
<b>Figure 26:</b> Mass displacement (D1). ....	14
<b>Figure 27:</b> EW displacement in shaking table (D2). ....	15
<b>Figure 28:</b> NS Displacement in shaking table (D3).....	15

### Test 3 - PGA=0.1g with a 0.1 seconds discharge

<b>Figure 29:</b> EW acceleration in shaking table.....	19
<b>Figure 30:</b> NS acceleration in shaking table.....	19
<b>Figure 31:</b> Bottom EW acceleration (A1).....	19
<b>Figure 32:</b> Bottom NS Acceleration (A2).....	20
<b>Figure 33:</b> Air Bag Pressure Trigger. ....	20
<b>Figure 34:</b> Mass EW acceleration (A4). ....	20
<b>Figure 35:</b> Mass NS acceleration (A5). ....	21
<b>Figure 36:</b> Mass vertical acceleration (A6).....	21
<b>Figure 37:</b> Top EW acceleration (A7).....	21
<b>Figure 38:</b> Top NS acceleration (A8). ....	22
<b>Figure 39:</b> Top vertical acceleration (A9). ....	22

<b>Figure 40:</b> Mass displacement (D1).....	22
<b>Figure 41:</b> EW displacement in shaking table (D2).....	23
<b>Figure 42:</b> NS Displacement in shaking table (D3).....	23

#### **Test 4 - PGA=0.4g without discharge**

<b>Figure 43:</b> EW acceleration in shaking table.....	27
<b>Figure 44:</b> NS acceleration in shaking table.....	27
<b>Figure 45:</b> Bottom EW acceleration (A1).....	27
<b>Figure 46:</b> Bottom NS Acceleration (A2).....	28
<b>Figure 47:</b> Air Bag Pressure Trigger.....	28
<b>Figure 48:</b> Mass EW acceleration (A4).....	28
<b>Figure 49:</b> Mass NS acceleration (A5).....	29
<b>Figure 50:</b> Mass vertical acceleration (A6).....	29
<b>Figure 51:</b> Top EW acceleration (A7).....	29
<b>Figure 52:</b> Top NS acceleration (A8).....	30
<b>Figure 53:</b> Top vertical acceleration (A9).....	30
<b>Figure 54:</b> Mass displacement (D1).....	30
<b>Figure 55:</b> EW displacement in shaking table (D2).....	31
<b>Figure 56:</b> NS Displacement in shaking table (D3).....	31

#### **Test 5 - PGA=0.4g with a 5 seconds discharge**

<b>Figure 57:</b> EW acceleration in shaking table.....	35
<b>Figure 58:</b> NS acceleration in shaking table.....	35
<b>Figure 59:</b> Bottom EW acceleration (A1).....	35
<b>Figure 60:</b> Bottom NS Acceleration (A2).....	36
<b>Figure 61:</b> Air Bag Pressure Trigger.....	36
<b>Figure 62:</b> Mass EW acceleration (A4).....	36
<b>Figure 63:</b> Mass NS acceleration (A5).....	37
<b>Figure 64:</b> Mass vertical acceleration (A6).....	37
<b>Figure 65:</b> Top EW acceleration (A7).....	37
<b>Figure 66:</b> Top NS acceleration (A8).....	38
<b>Figure 67:</b> Top vertical acceleration (A9).....	38
<b>Figure 68:</b> Mass displacement (D1).....	38
<b>Figure 69:</b> EW displacement in shaking table (D2).....	39
<b>Figure 70:</b> NS Displacement in shaking table (D3).....	39

#### **Test 6 - PGA=0.4g with a 0.1 seconds discharge**

<b>Figure 71:</b> EW acceleration in shaking table.....	43
<b>Figure 72:</b> NS acceleration in shaking table.....	43
<b>Figure 73:</b> Bottom EW acceleration (A1).....	43
<b>Figure 74:</b> Bottom NS Acceleration (A2).....	44
<b>Figure 75:</b> Air Bag Pressure Trigger.....	44
<b>Figure 76:</b> Mass EW acceleration (A4).....	44
<b>Figure 77:</b> Mass NS acceleration (A5).....	45
<b>Figure 78:</b> Mass vertical acceleration (A6).....	45
<b>Figure 79:</b> Top EW acceleration (A7).....	45
<b>Figure 80:</b> Top NS acceleration (A8).....	46
<b>Figure 81:</b> Top vertical acceleration (A9).....	46
<b>Figure 82:</b> Mass displacement (D1).....	46

<b>Figure 83:</b> EW displacement in shaking table (D2).	47
<b>Figure 84:</b> NS Displacement in shaking table (D3).	47

**Test 7 - PGA=0.6g without discharge**

<b>Figure 85:</b> EW acceleration in shaking table.	51
<b>Figure 86:</b> NS acceleration in shaking table.	51
<b>Figure 87:</b> Bottom EW acceleration (A1).	51
<b>Figure 88:</b> Bottom NS Acceleration (A2).	52
<b>Figure 89:</b> Air Bag Pressure Trigger.	52
<b>Figure 90:</b> Mass EW acceleration (A4).	52
<b>Figure 91:</b> Mass NS acceleration (A5).	53
<b>Figure 92:</b> Mass vertical acceleration (A6).	53
<b>Figure 93:</b> Top EW acceleration (A7).	53
<b>Figure 94:</b> Top NS acceleration (A8).	54
<b>Figure 95:</b> Top vertical acceleration (A9).	54
<b>Figure 96:</b> Mass displacement (D1).	54
<b>Figure 97:</b> EW displacement in shaking table (D2).	55
<b>Figure 98:</b> NS Displacement in shaking table (D3).	55

**Test 8 - PGA=0.6g with a 5 seconds discharge**

<b>Figure 99:</b> EW acceleration in shaking table.	59
<b>Figure 100:</b> NS acceleration in shaking table.	59
<b>Figure 101:</b> Bottom EW acceleration (A1).	59
<b>Figure 102:</b> Bottom NS Acceleration (A2).	60
<b>Figure 103:</b> Air Bag Pressure Trigger.	60
<b>Figure 104:</b> Mass EW acceleration (A4).	60
<b>Figure 105:</b> Mass NS acceleration (A5).	61
<b>Figure 106:</b> Mass vertical acceleration (A6).	61
<b>Figure 107:</b> Top EW acceleration (A7).	61
<b>Figure 108:</b> Top NS acceleration (A8).	62
<b>Figure 109:</b> Top vertical acceleration (A9).	62
<b>Figure 110:</b> Mass displacement (D1).	62
<b>Figure 111:</b> EW displacement in shaking table (D2).	63
<b>Figure 112:</b> NS Displacement in shaking table (D3).	63

**Test 9 - PGA=0.6g with a 0.1 seconds discharge**

<b>Figure 113:</b> EW acceleration in shaking table.	67
<b>Figure 114:</b> NS acceleration in shaking table.	67
<b>Figure 115:</b> Bottom EW acceleration (A1).	67
<b>Figure 116:</b> Bottom NS Acceleration (A2).	68
<b>Figure 117:</b> Air Bag Pressure Trigger.	68
<b>Figure 118:</b> Mass EW acceleration (A4).	68
<b>Figure 119:</b> Mass NS acceleration (A5).	69
<b>Figure 120:</b> Mass vertical acceleration (A6).	69
<b>Figure 121:</b> Top EW acceleration (A7).	69
<b>Figure 122:</b> Top NS acceleration (A8).	70
<b>Figure 123:</b> Top vertical acceleration (A9).	70
<b>Figure 124:</b> Mass displacement (D1).	70

<b>Figure 125:</b> EW displacement in shaking table (D2).....	71
<b>Figure 126:</b> NS Displacement in shaking table (D3).....	71

**Test 10 - PGA=0.8g without discharge**

<b>Figure 127:</b> EW acceleration in shaking table.....	75
<b>Figure 128:</b> NS acceleration in shaking table. ....	75
<b>Figure 129:</b> Bottom EW acceleration (A1). ....	75
<b>Figure 130:</b> Bottom NS Acceleration (A2).....	76
<b>Figure 131:</b> Air Bag Pressure Trigger.....	76
<b>Figure 132:</b> Mass EW acceleration (A4).....	76
<b>Figure 133:</b> Mass NS acceleration (A5).....	77
<b>Figure 134:</b> Mass vertical acceleration (A6).....	77
<b>Figure 135:</b> Top EW acceleration (A7). ....	77
<b>Figure 136:</b> Top NS acceleration (A8). ....	78
<b>Figure 137:</b> Top vertical acceleration (A9).....	78
<b>Figure 138:</b> Mass displacement (D1).....	78
<b>Figure 139:</b> EW displacement in shaking table (D2).....	79
<b>Figure 140:</b> NS Displacement in shaking table (D3).....	79

**Test 11 - PGA=0.8g with a 5 seconds discharge**

<b>Figure 141:</b> EW acceleration in shaking table.....	83
<b>Figure 142:</b> NS acceleration in shaking table. ....	83
<b>Figure 143:</b> Bottom EW acceleration (A1). ....	83
<b>Figure 144:</b> Bottom NS Acceleration (A2).....	84
<b>Figure 145:</b> Air Bag Pressure Trigger.....	84
<b>Figure 146:</b> Mass EW acceleration (A4).....	84
<b>Figure 147:</b> Mass NS acceleration (A5).....	85
<b>Figure 148:</b> Mass vertical acceleration (A6).....	85
<b>Figure 149:</b> Top EW acceleration (A7). ....	85
<b>Figure 150:</b> Top NS acceleration (A8). ....	86
<b>Figure 151:</b> Top vertical acceleration (A9).....	86
<b>Figure 152:</b> Mass displacement (D1).....	86
<b>Figure 153:</b> EW displacement in shaking table (D2).....	87
<b>Figure 154:</b> NS Displacement in shaking table (D3).....	87

**Test 12 - PGA=0.8g with a 0.1 seconds discharge**

<b>Figure 155:</b> EW acceleration in shaking table.....	91
<b>Figure 156:</b> NS acceleration in shaking table. ....	91
<b>Figure 157:</b> Bottom EW acceleration (A1). ....	91
<b>Figure 158:</b> Bottom NS Acceleration (A2).....	92
<b>Figure 159:</b> Air Bag Pressure Trigger.....	92
<b>Figure 160:</b> Mass EW acceleration (A4).....	92
<b>Figure 161:</b> Mass NS acceleration (A5).....	93
<b>Figure 162:</b> Mass vertical acceleration (A6).....	93
<b>Figure 163:</b> Top EW acceleration (A7). ....	93
<b>Figure 164:</b> Top NS acceleration (A8). ....	94
<b>Figure 165:</b> Top vertical acceleration (A9).....	94
<b>Figure 166:</b> Mass displacement (D1).....	94
<b>Figure 167:</b> EW displacement in shaking table (D2).....	95

<b>Figure 168:</b> NS Displacement in shaking table (D3).	95
---	----

**Test 13 - PGA=1.0g with a 0.1 seconds discharge**

<b>Figure 169:</b> EW acceleration in shaking table.	99
<b>Figure 170:</b> NS acceleration in shaking table.	99
<b>Figure 171:</b> Bottom EW acceleration (A1).	99
<b>Figure 172:</b> Bottom NS Acceleration (A2).	100
<b>Figure 173:</b> Air Bag Pressure Trigger.	100
<b>Figure 174:</b> Mass EW acceleration (A4).	100
<b>Figure 175:</b> Mass NS acceleration (A5).	101
<b>Figure 176:</b> Mass vertical acceleration (A6).	101
<b>Figure 177:</b> Top EW acceleration (A7).	101
<b>Figure 178:</b> Top NS acceleration (A8).	102
<b>Figure 179:</b> Top vertical acceleration (A9).	102
<b>Figure 180:</b> Mass displacement (D1).	102
<b>Figure 181:</b> EW displacement in shaking table (D2).	103
<b>Figure 182:</b> NS Displacement in shaking table (D3).	103

**Test 14 - PGA=1.2g with a 0.1 seconds discharge**

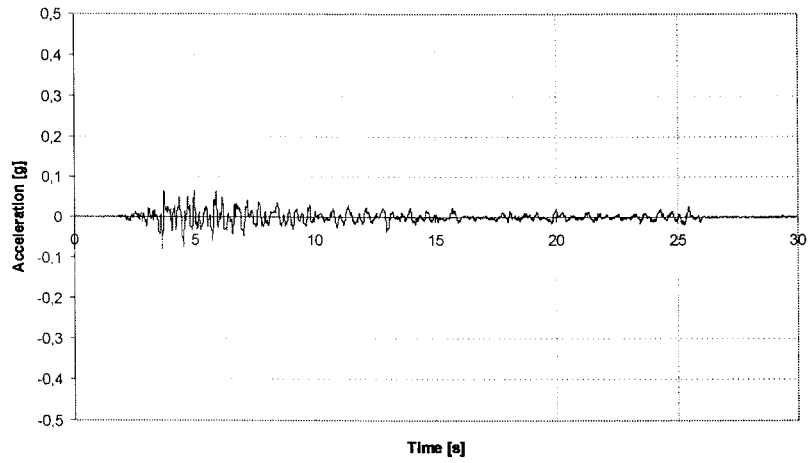
<b>Figure 183:</b> EW acceleration in shaking table.	107
<b>Figure 184:</b> NS acceleration in shaking table.	107
<b>Figure 185:</b> Bottom EW acceleration (A1).	107
<b>Figure 186:</b> Bottom NS Acceleration (A2).	108
<b>Figure 187:</b> Air Bag Pressure Trigger.	108
<b>Figure 188:</b> Mass EW acceleration (A4).	108
<b>Figure 189:</b> Mass NS acceleration (A5).	109
<b>Figure 190:</b> Mass vertical acceleration (A6).	109
<b>Figure 191:</b> Top EW acceleration (A7).	109
<b>Figure 192:</b> Top NS acceleration (A8).	110
<b>Figure 193:</b> Top vertical acceleration (A9).	110
<b>Figure 194:</b> Mass displacement (D1).	110
<b>Figure 195:</b> EW displacement in shaking table (D2).	111
<b>Figure 196:</b> NS Displacement in shaking table (D3).	111



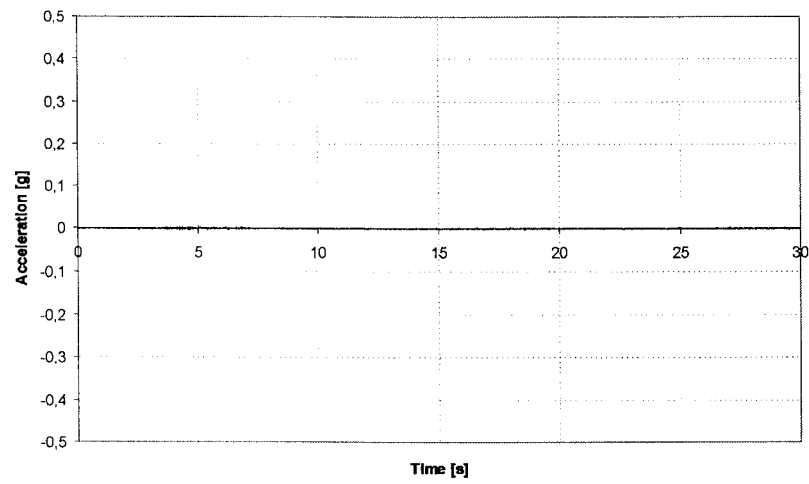
**Test 1– PGA=0.1g without discharge**



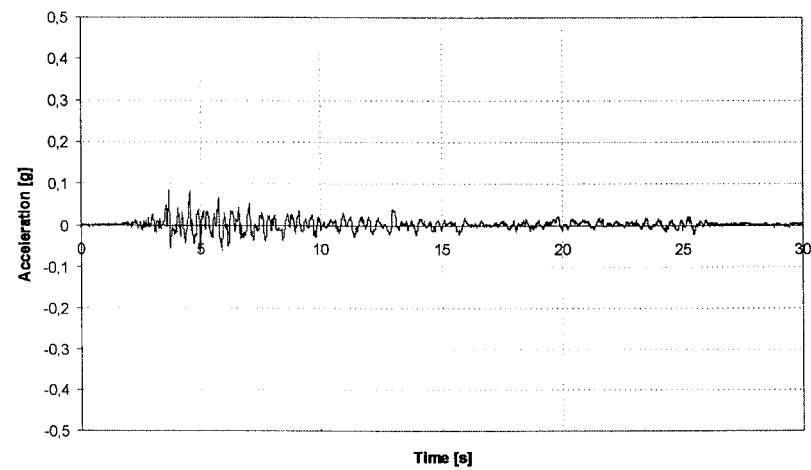




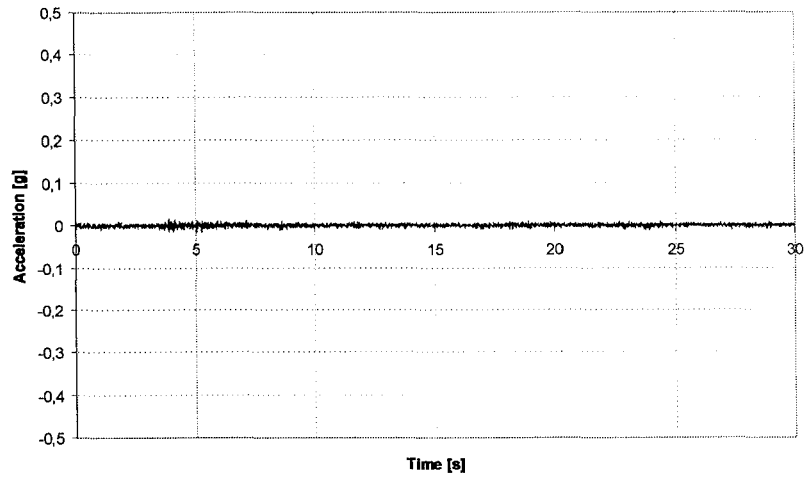
**Figure 1:** EW acceleration in shaking table.



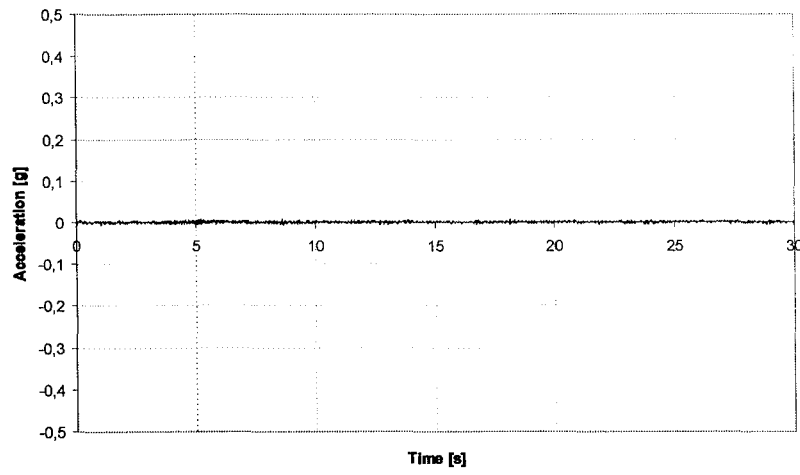
**Figure 2:** NS acceleration in shaking table.



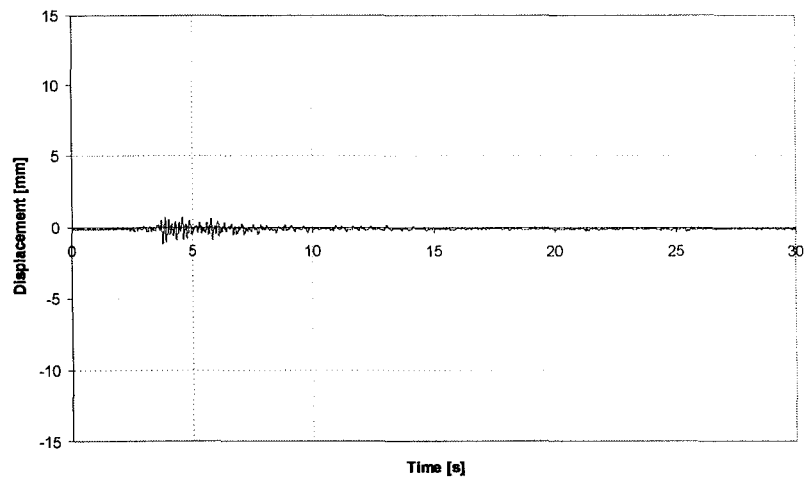
**Figure 3:** Bottom EW acceleration (A1).



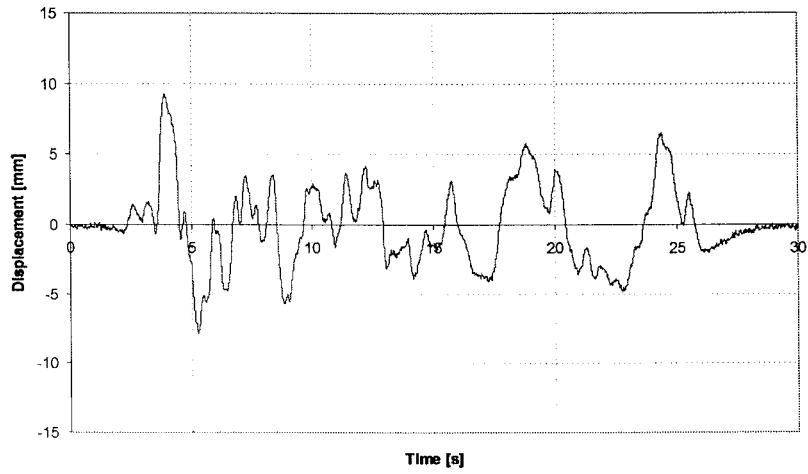
**Figure 10:** Top NS acceleration (A8).



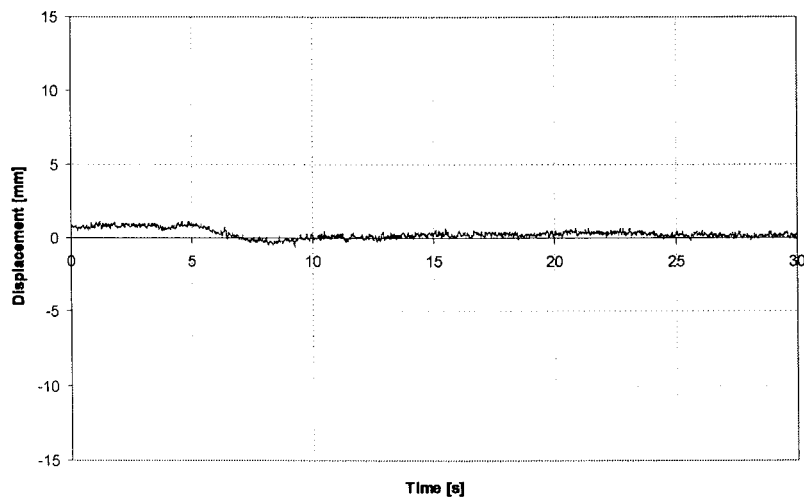
**Figure 11:** Top vertical acceleration (A9).



**Figure 12:** Mass displacement (D1).



**Figure 13:** EW displacement in shaking table (D2).

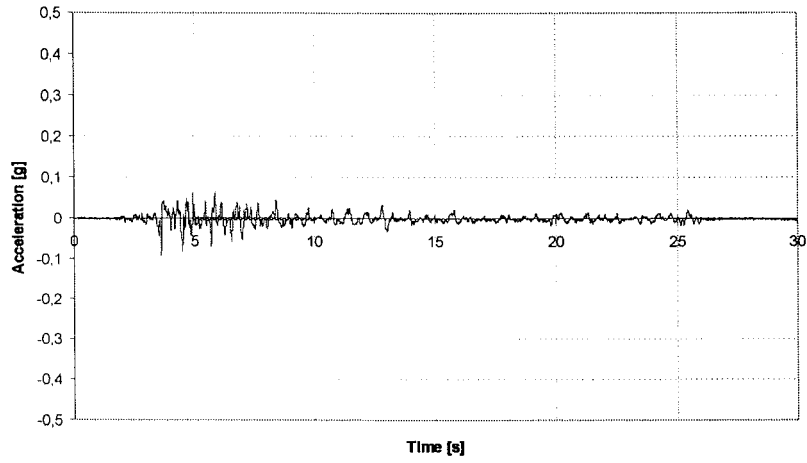


**Figure 14:** NS Displacement in shaking table (D3).

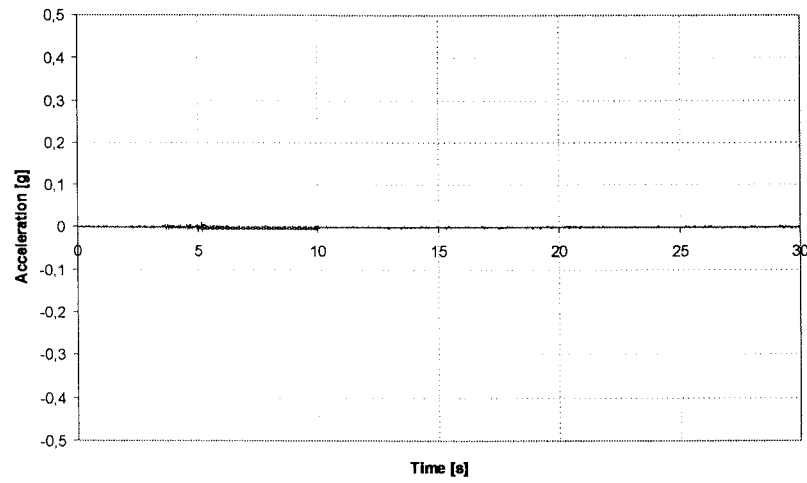


**Test 2 – PGA=0.1g with a 5 seconds discharge**

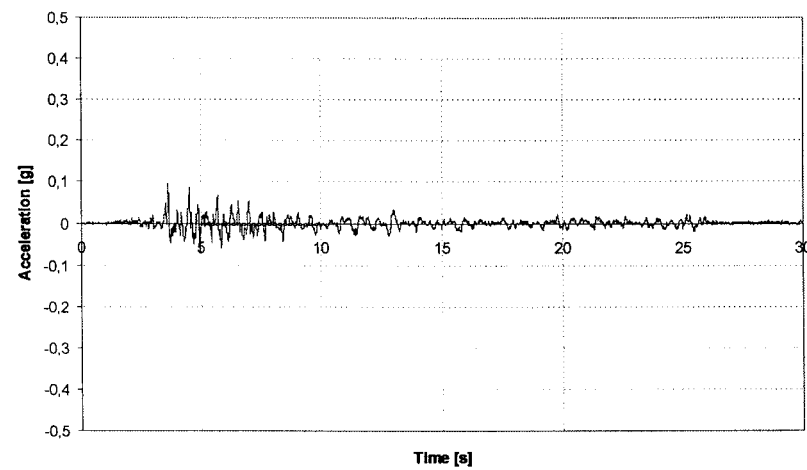




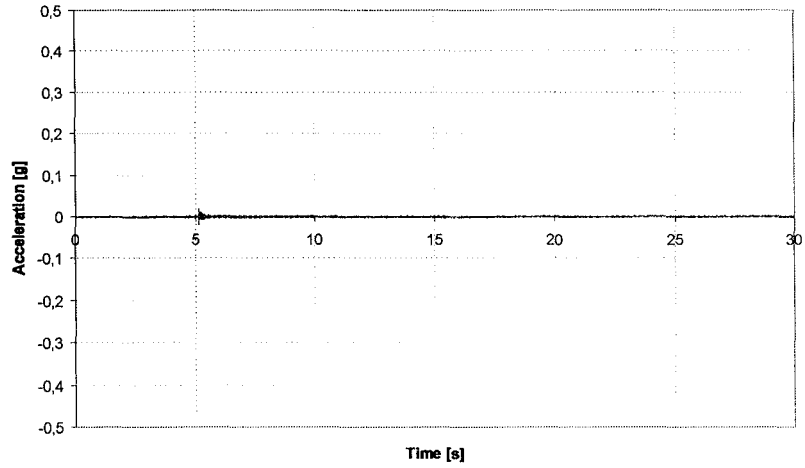
**Figure 15:** EW acceleration in shaking table.



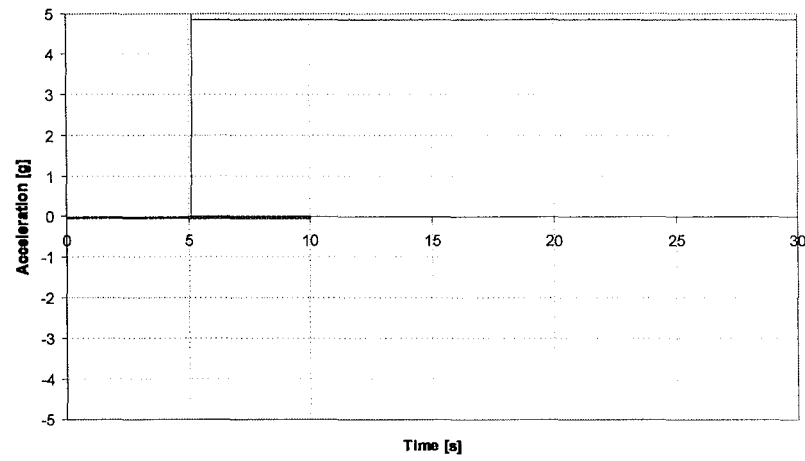
**Figure 16:** NS acceleration in shaking table.



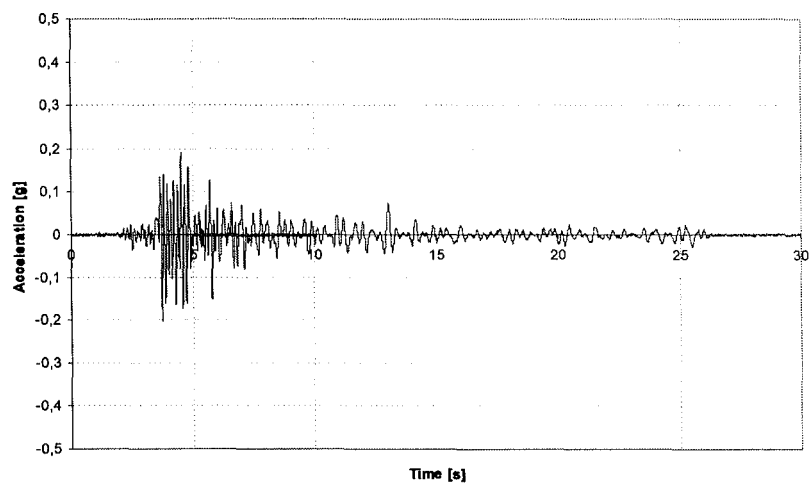
**Figure 17:** Bottom EW acceleration (A1).



**Figure 18:** Bottom NS Acceleration (A2).

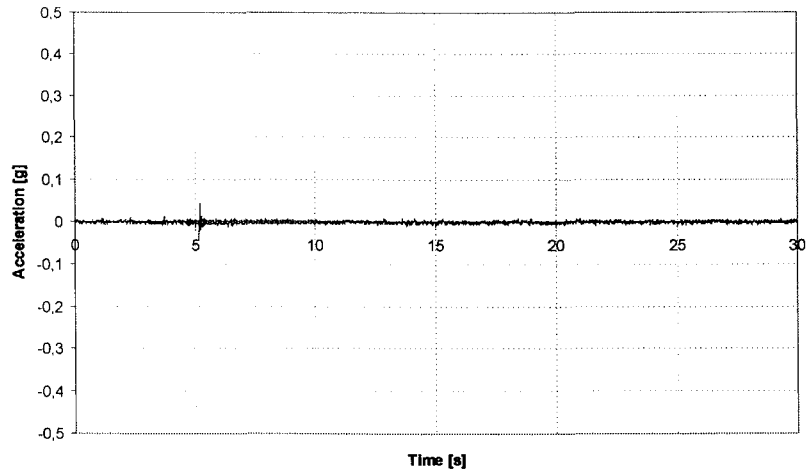


**Figure 19:** Air Bag Pressure Trigger.

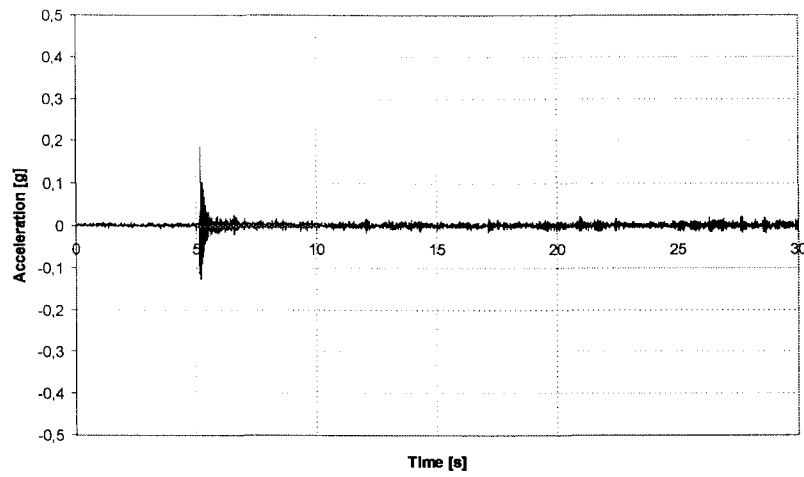


**Figure 20:** Mass EW acceleration (A4).

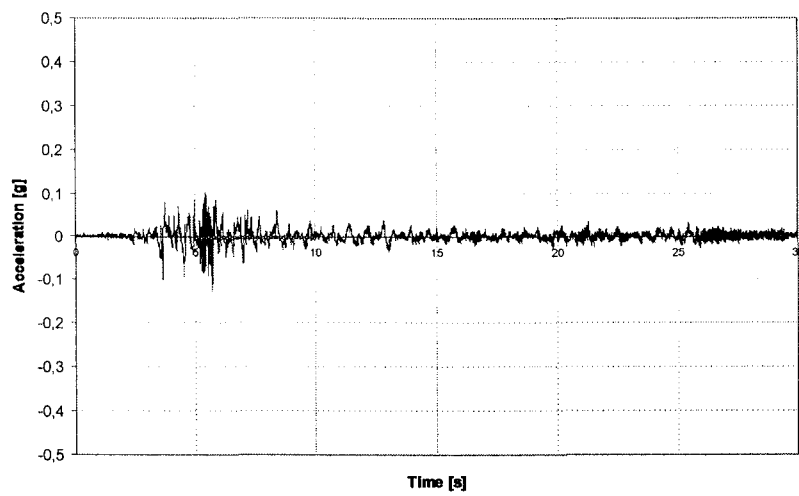




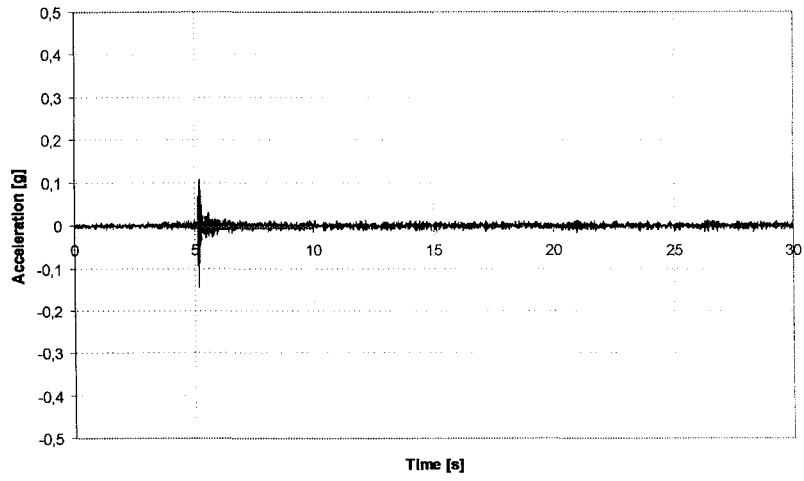
**Figure 21:** Mass NS acceleration (A5).



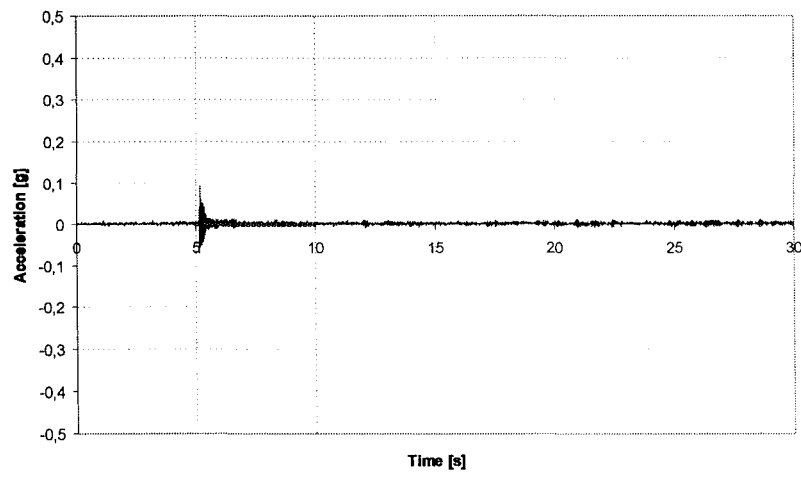
**Figure 22:** Mass vertical acceleration (A6).



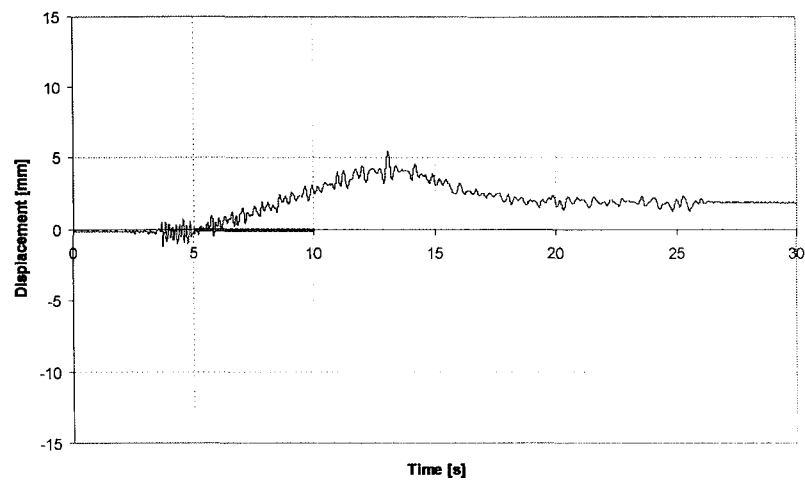
**Figure 23:** Top EW acceleration (A7).



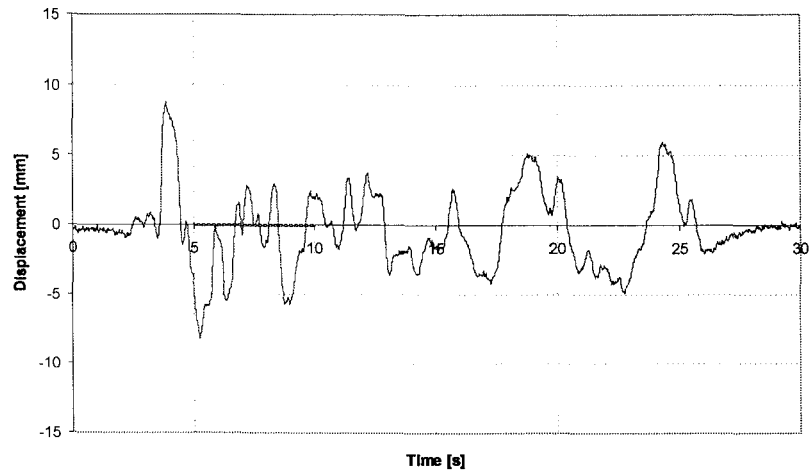
**Figure 24:** Top NS acceleration (A8).



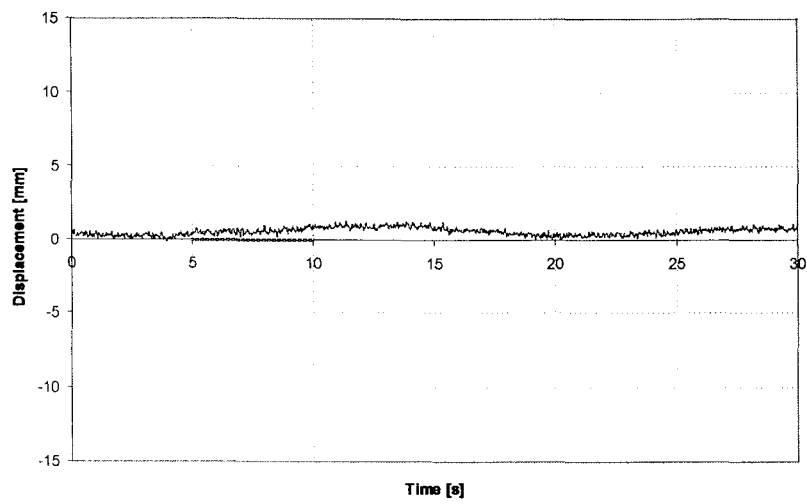
**Figure 25:** Top vertical acceleration (A9).



**Figure 26:** Mass displacement (D1).



**Figure 27:** EW displacement in shaking table (D2).

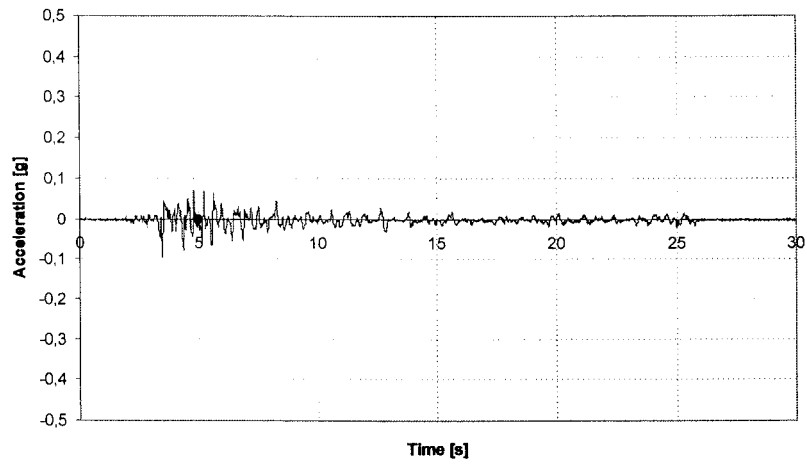


**Figure 28:** NS Displacement in shaking table (D3).

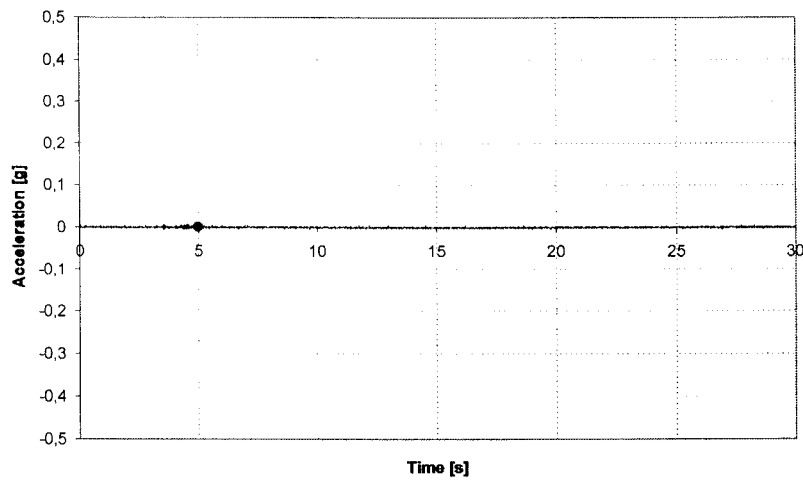


**Test 3 – PGA=0.1g with a 0.1 seconds discharge**

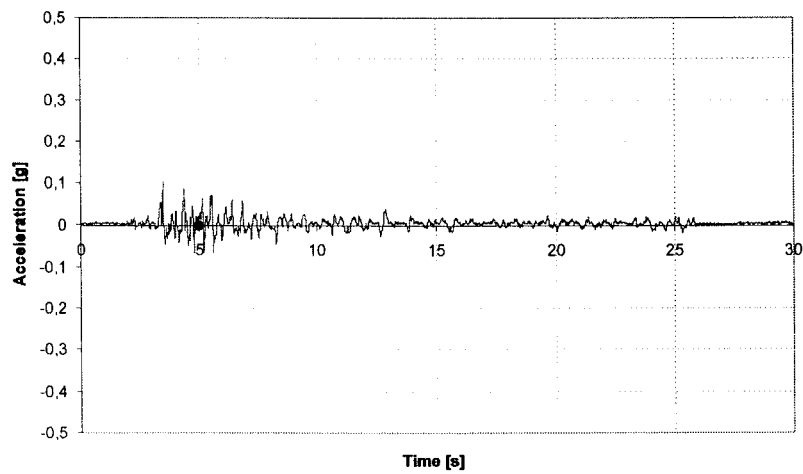




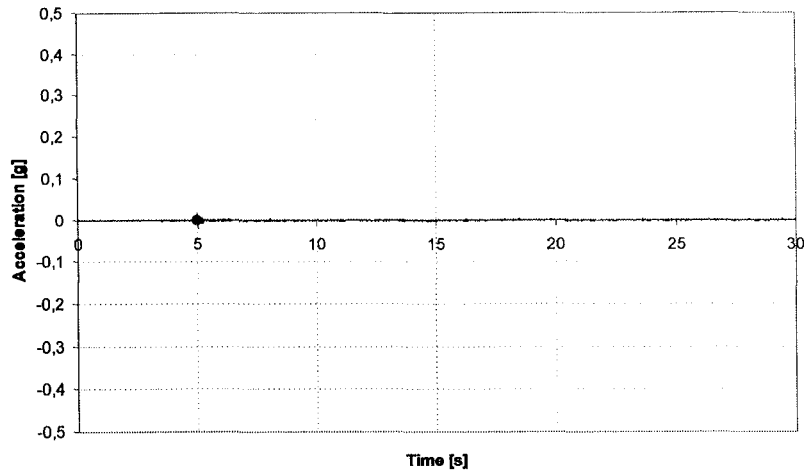
**Figure 29:** EW acceleration in shaking table.



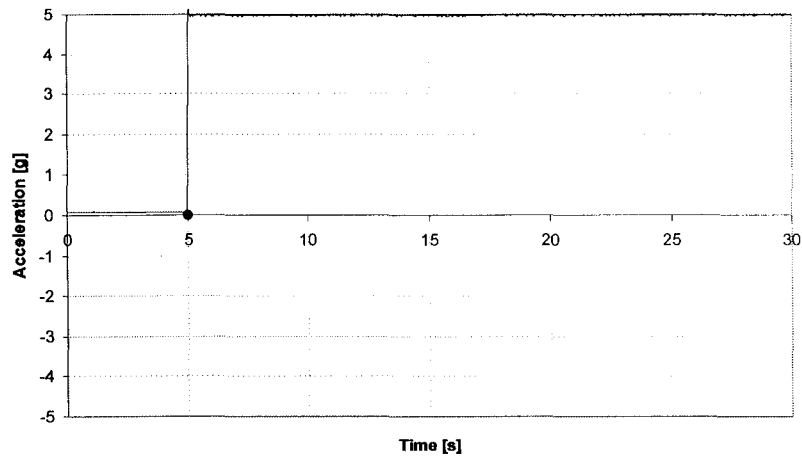
**Figure 30:** NS acceleration in shaking table.



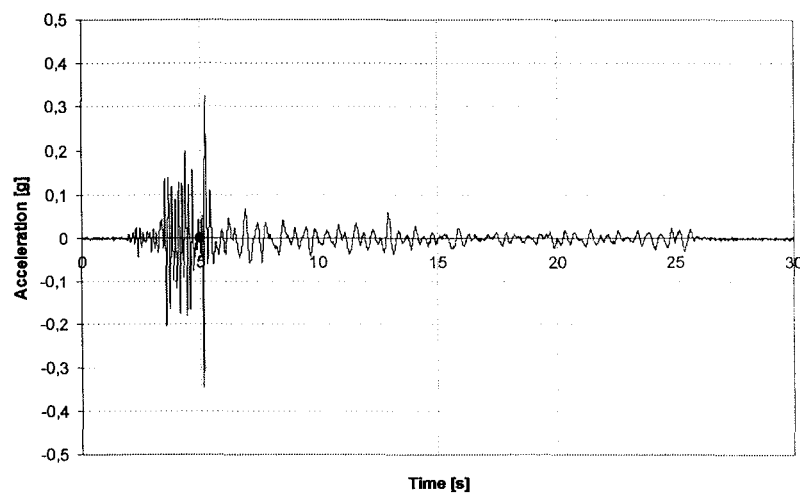
**Figure 31:** Bottom EW acceleration (A1).



**Figure 32:** Bottom NS Acceleration (A2).

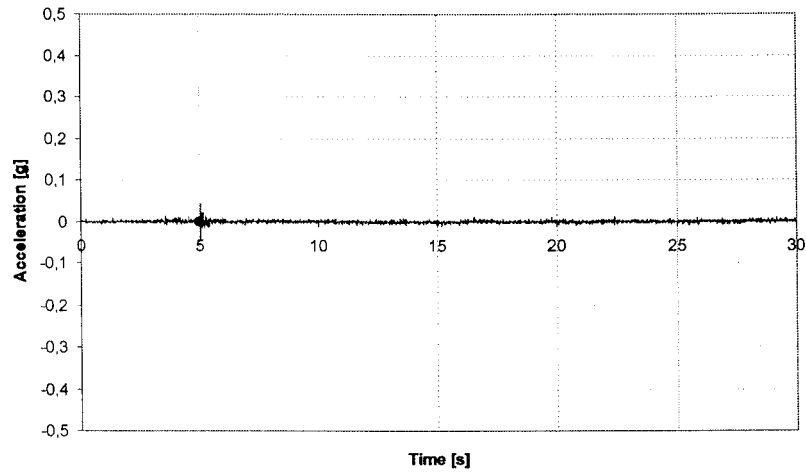


**Figure 33:** Air Bag Pressure Trigger.

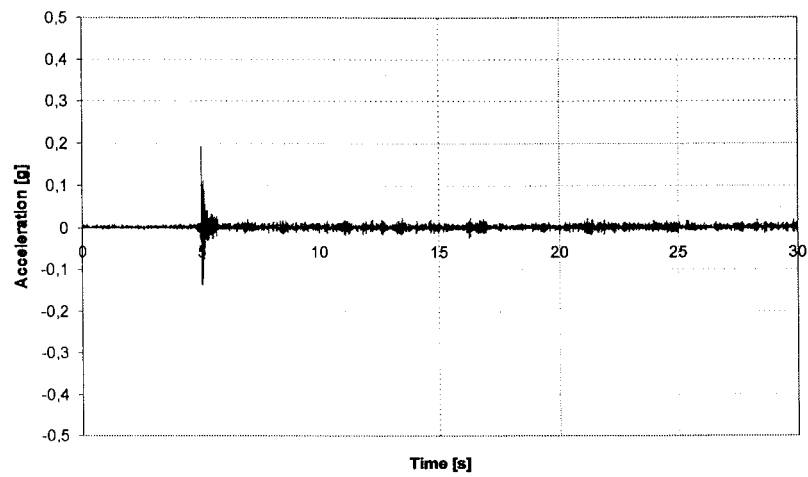


**Figure 34:** Mass EW acceleration (A4).

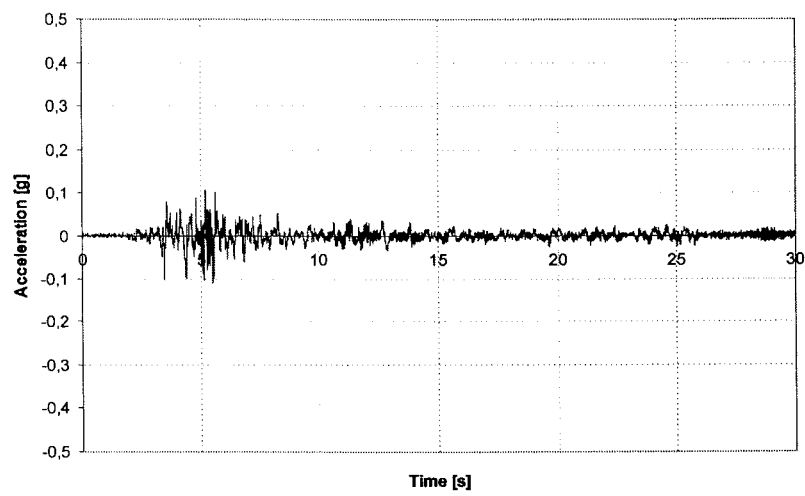




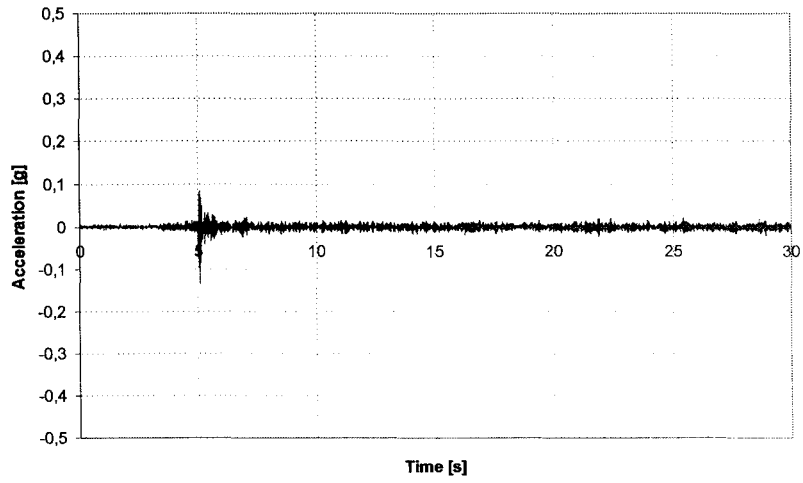
**Figure 35:** Mass NS acceleration (A5).



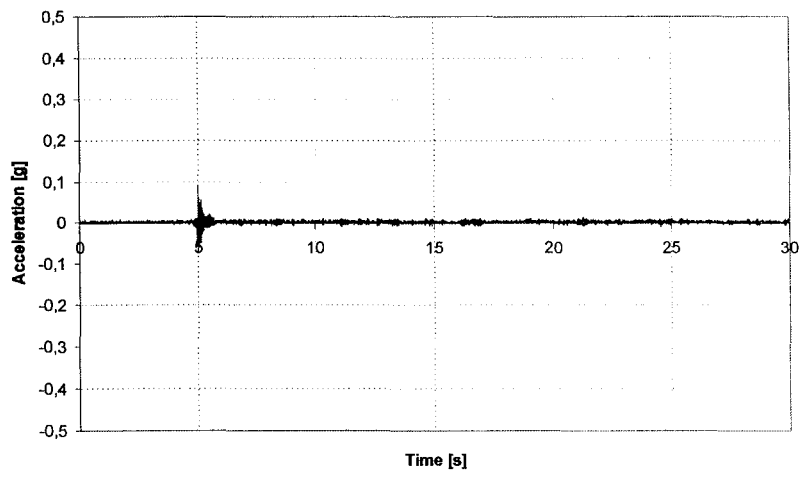
**Figure 36:** Mass vertical acceleration (A6).



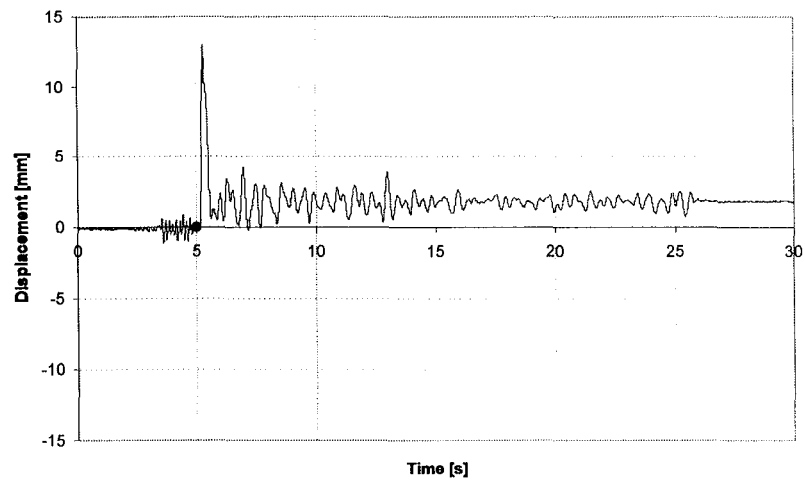
**Figure 37:** Top EW acceleration (A7).



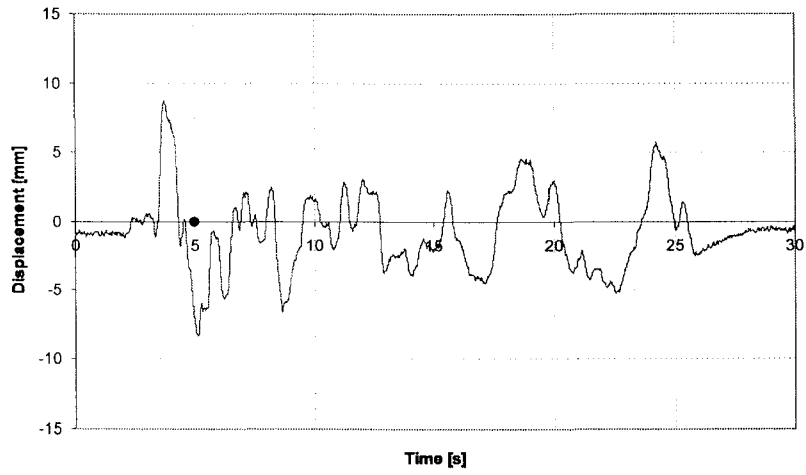
**Figure 38:** Top NS acceleration (A8).



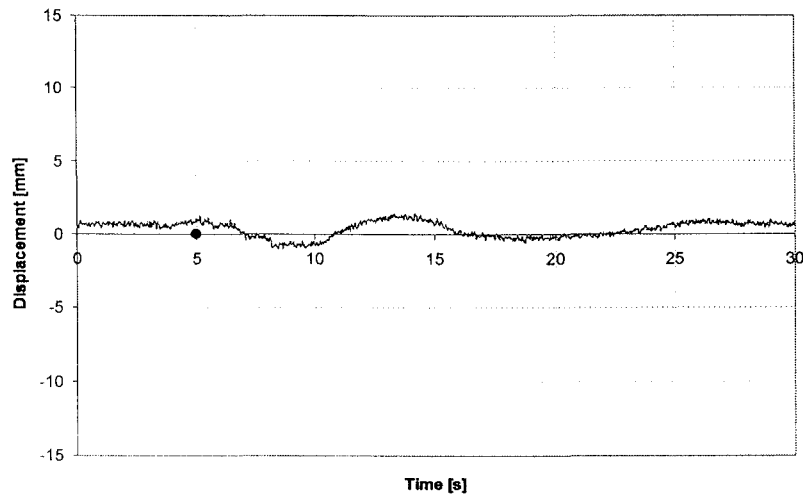
**Figure 39:** Top vertical acceleration (A9).



**Figure 40:** Mass displacement (D1).



**Figure 41:** EW displacement in shaking table (D2).

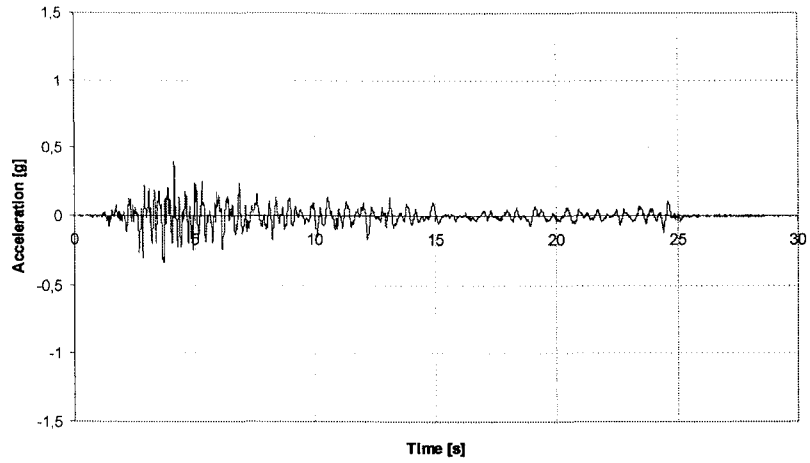


**Figure 42:** NS Displacement in shaking table (D3).

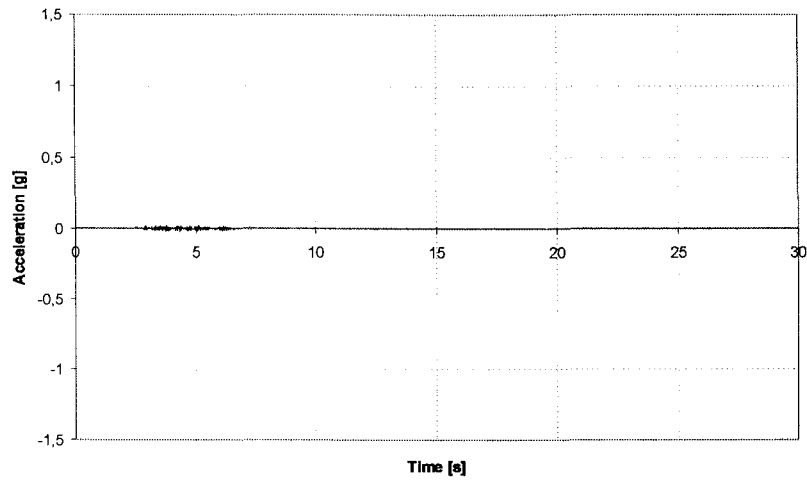


**Test 4 – PGA=0.4g without discharge**

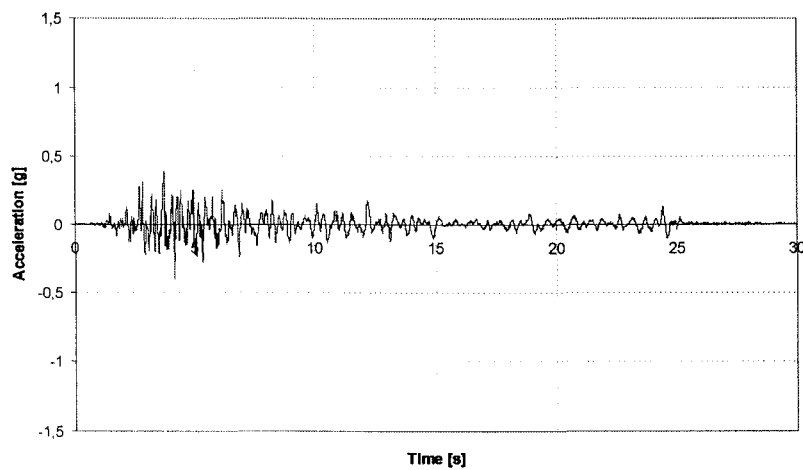




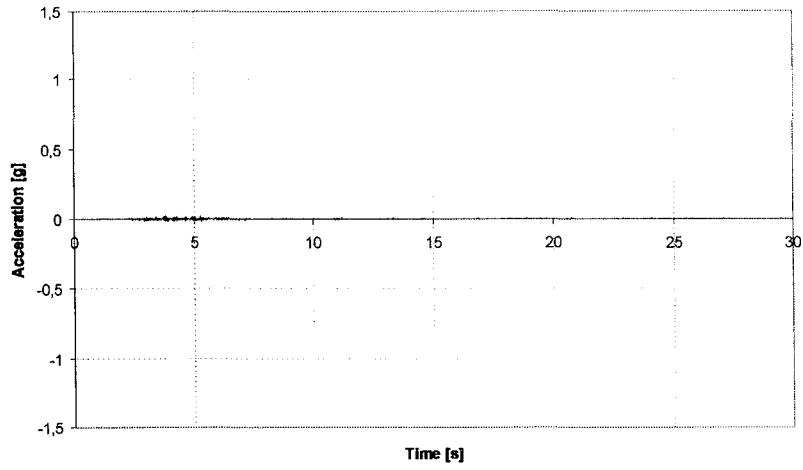
**Figure 43:** EW acceleration in shaking table.



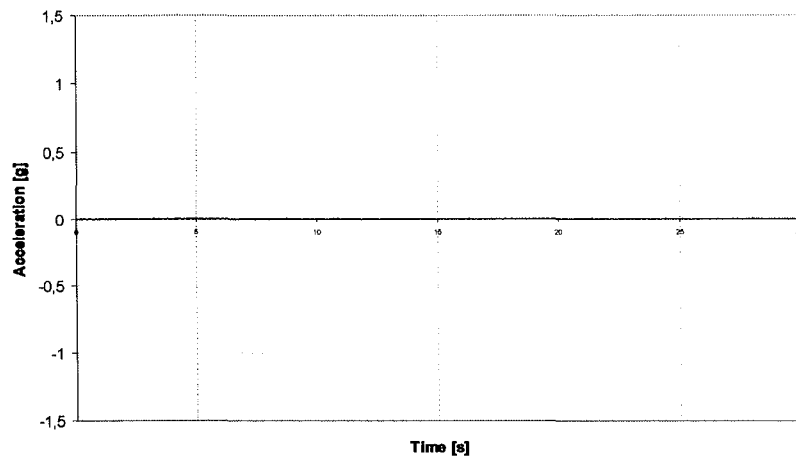
**Figure 44:** NS acceleration in shaking table.



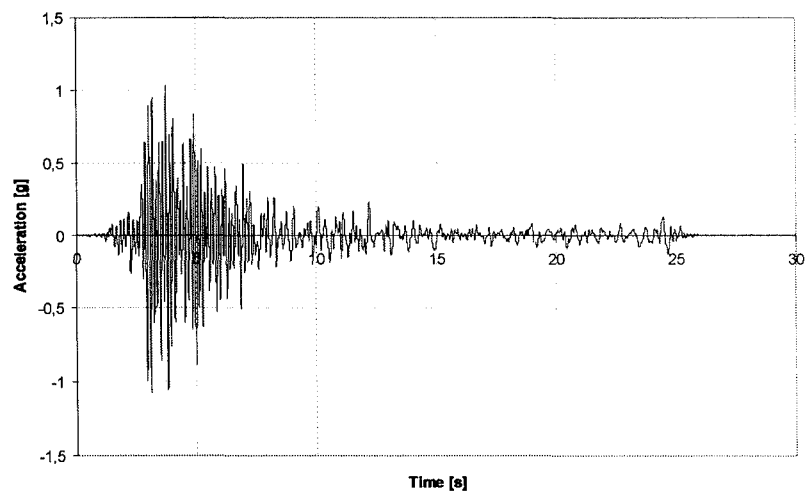
**Figure 45:** Bottom EW acceleration (A1).



**Figure 46:** Bottom NS Acceleration (A2).

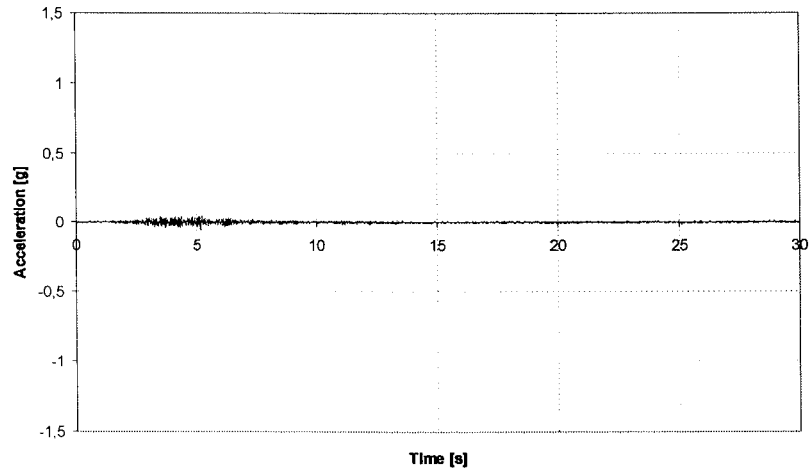


**Figure 47:** Air Bag Pressure Trigger.

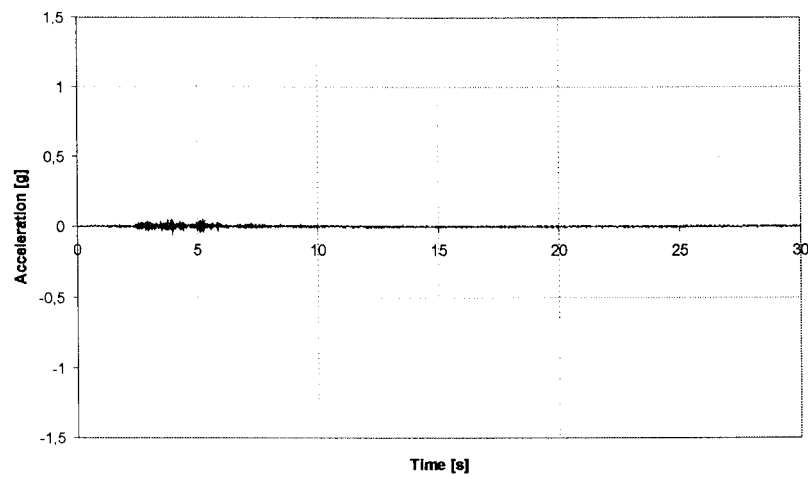


**Figure 48:** Mass EW acceleration (A4).

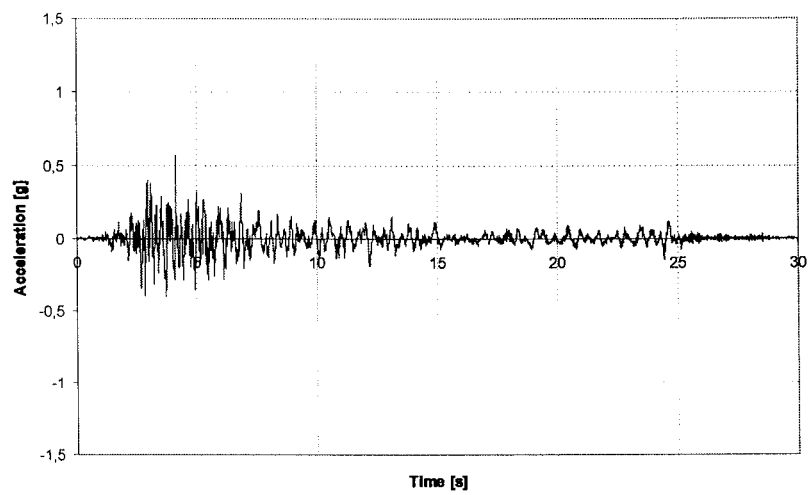




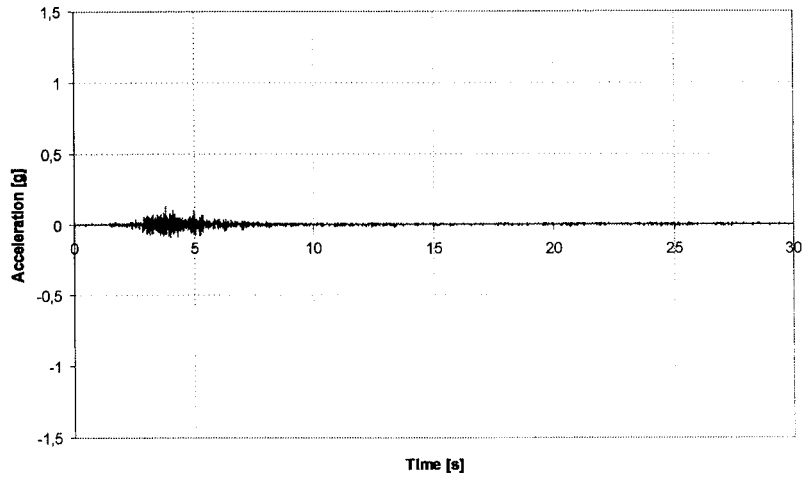
**Figure 49:** Mass NS acceleration (A5).



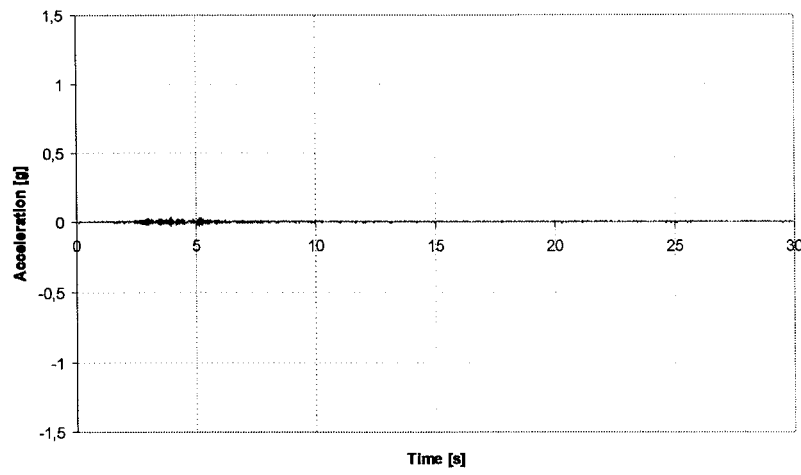
**Figure 50:** Mass vertical acceleration (A6).



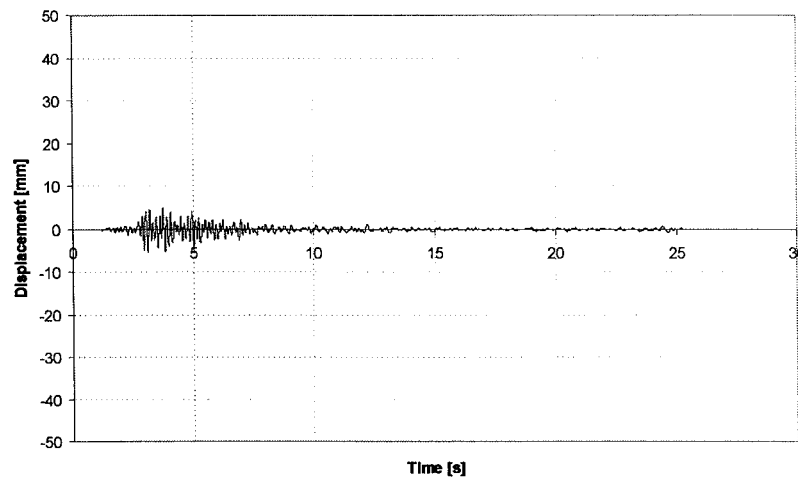
**Figure 51:** Top EW acceleration (A7).



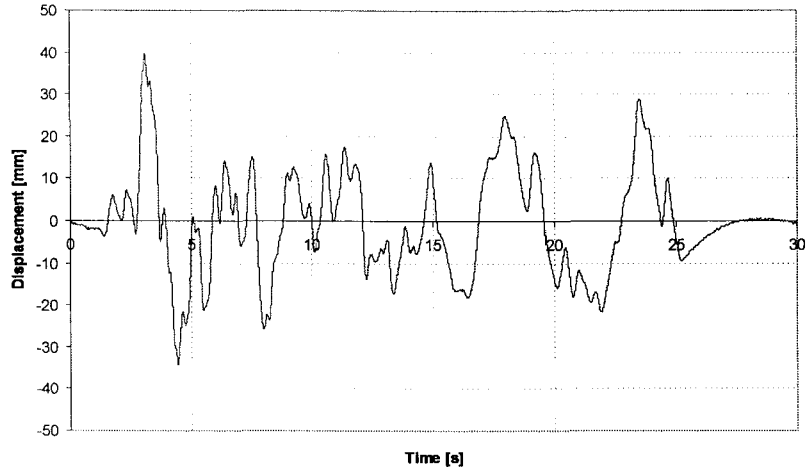
**Figure 52:** Top NS acceleration (A8).



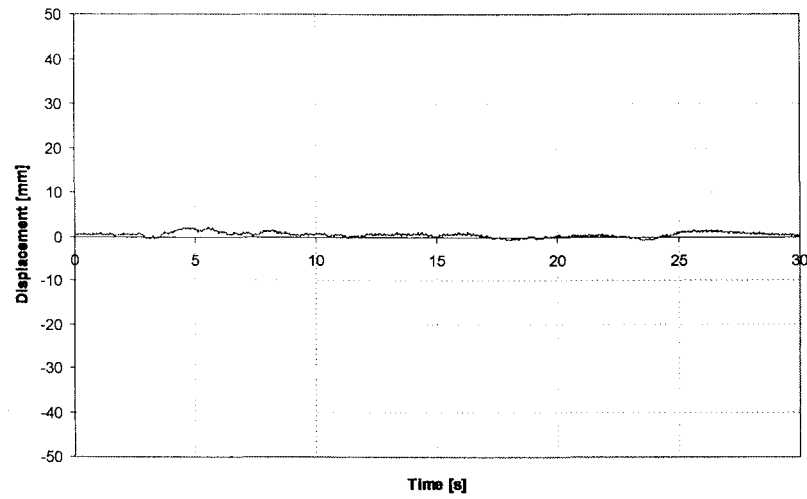
**Figure 53:** Top vertical acceleration (A9).



**Figure 54:** Mass displacement (D1).



**Figure 55:** EW displacement in shaking table (D2).

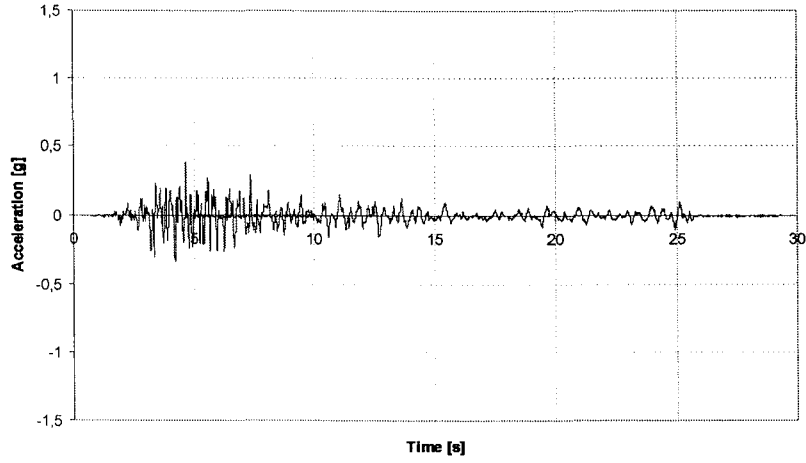


**Figure 56:** NS Displacement in shaking table (D3).

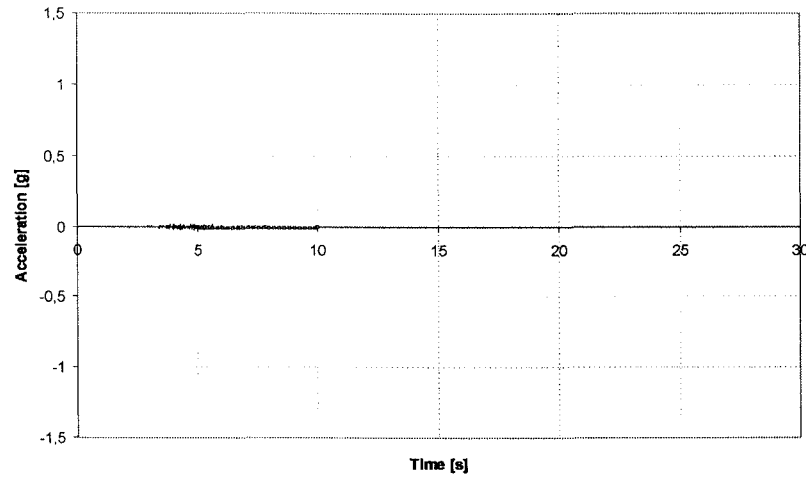


**Test 5 – PGA=0.4g with a 5 seconds discharge**

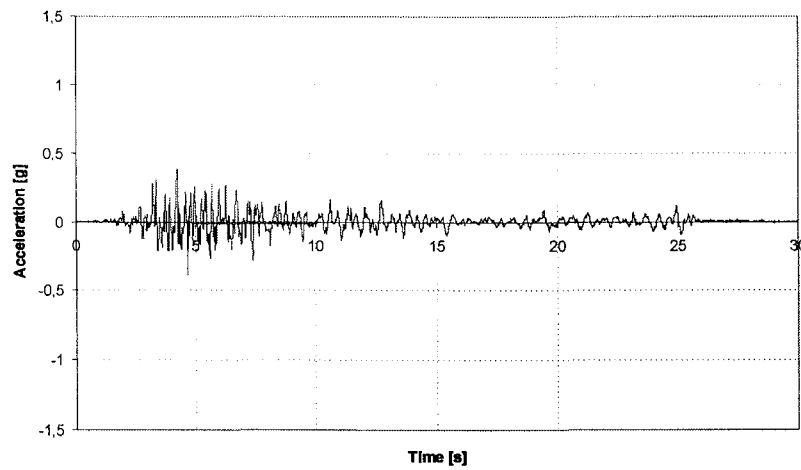




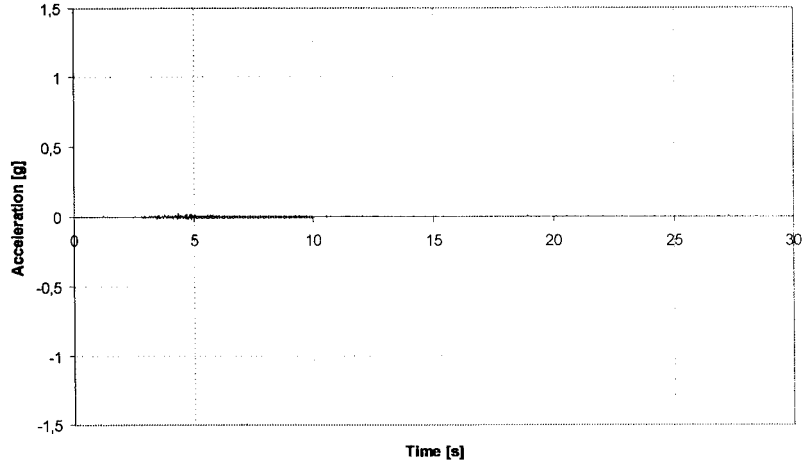
**Figure 57:** EW acceleration in shaking table.



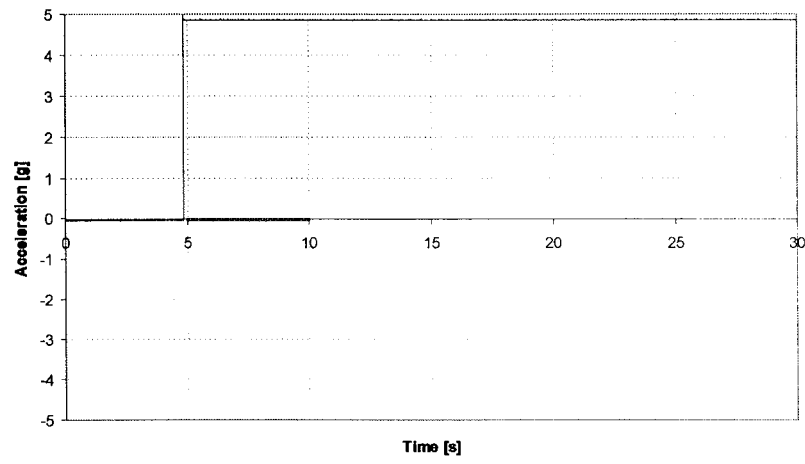
**Figure 58:** NS acceleration in shaking table.



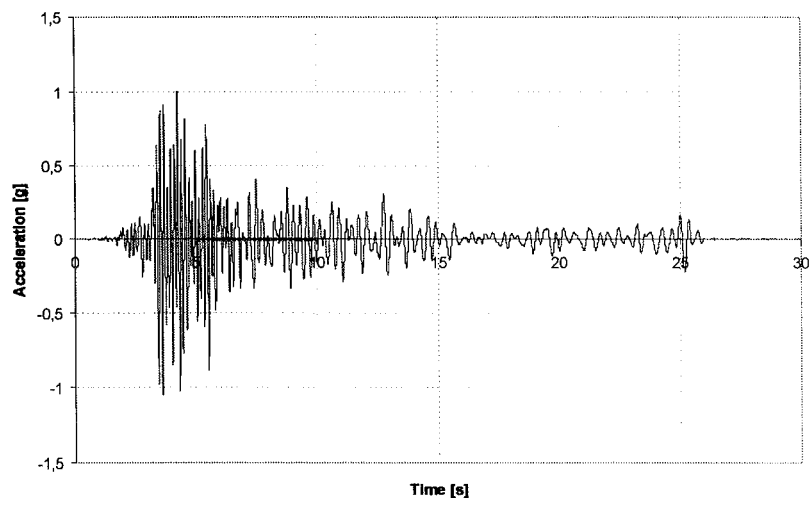
**Figure 59:** Bottom EW acceleration (A1).



**Figure 60:** Bottom NS Acceleration (A2).

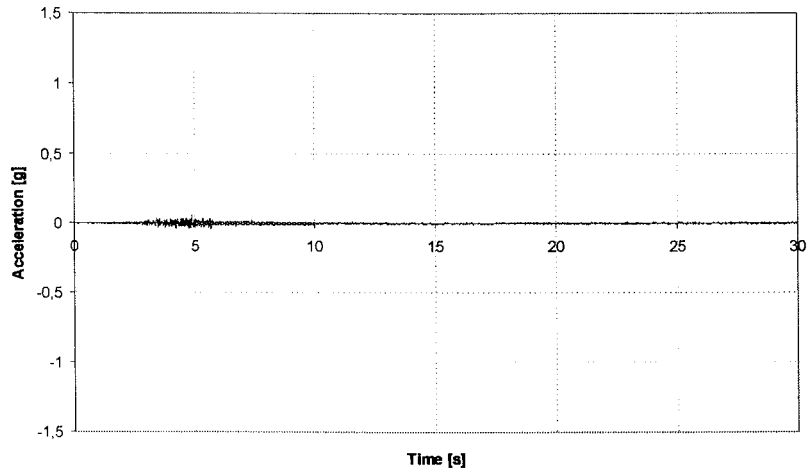


**Figure 61:** Air Bag Pressure Trigger.

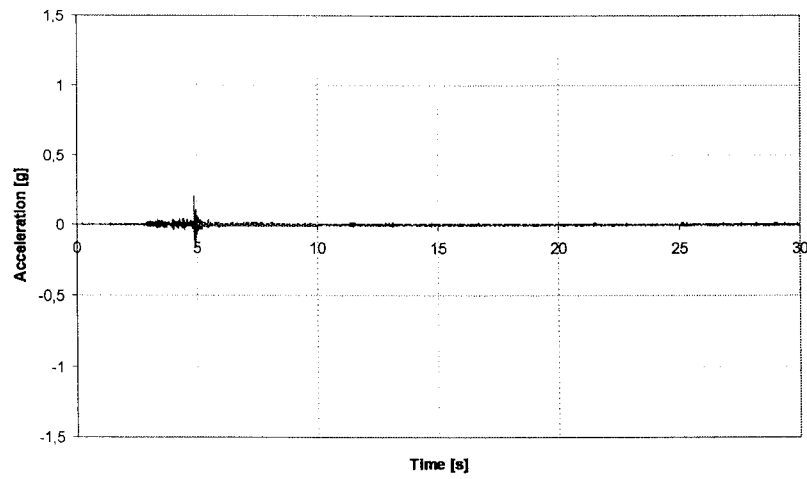


**Figure 62:** Mass EW acceleration (A4).

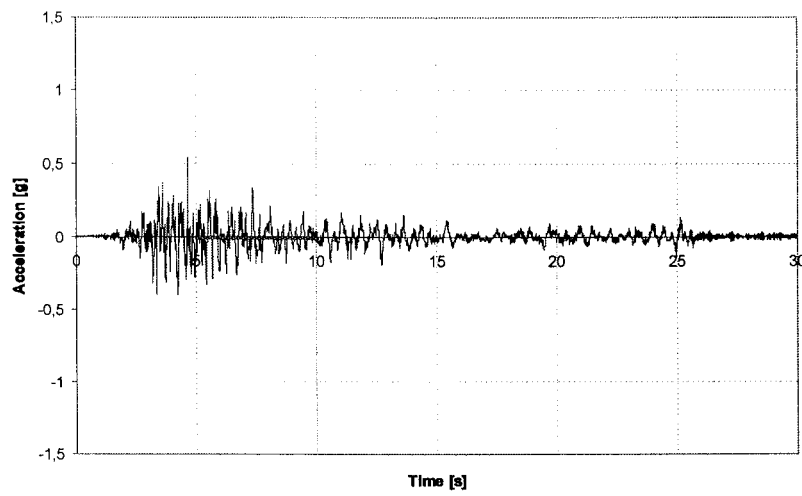




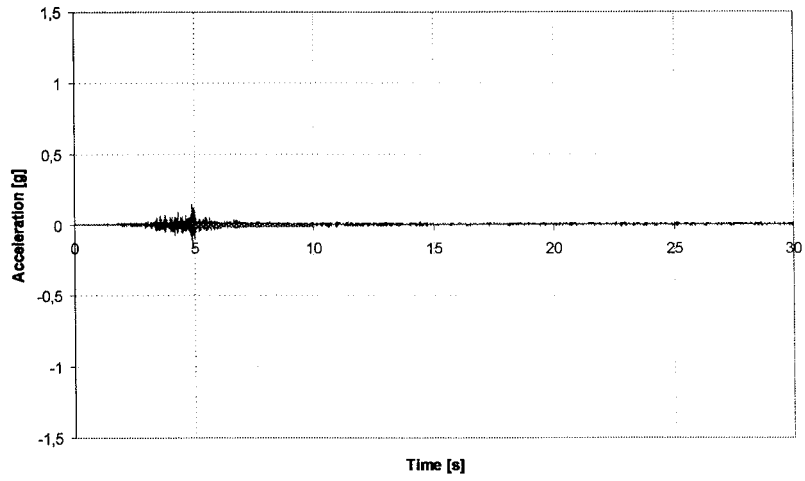
**Figure 63:** Mass NS acceleration (A5).



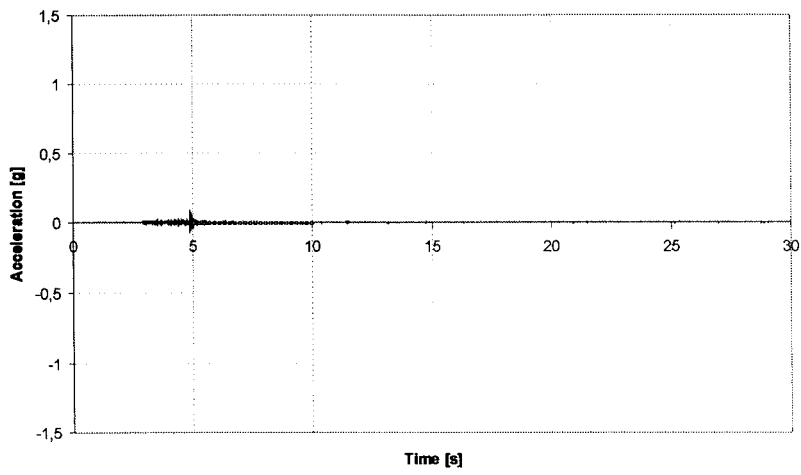
**Figure 64:** Mass vertical acceleration (A6).



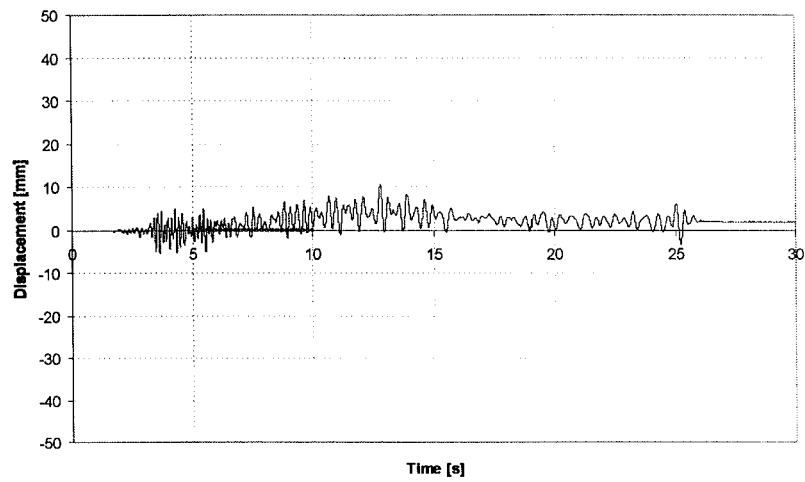
**Figure 65:** Top EW acceleration (A7).



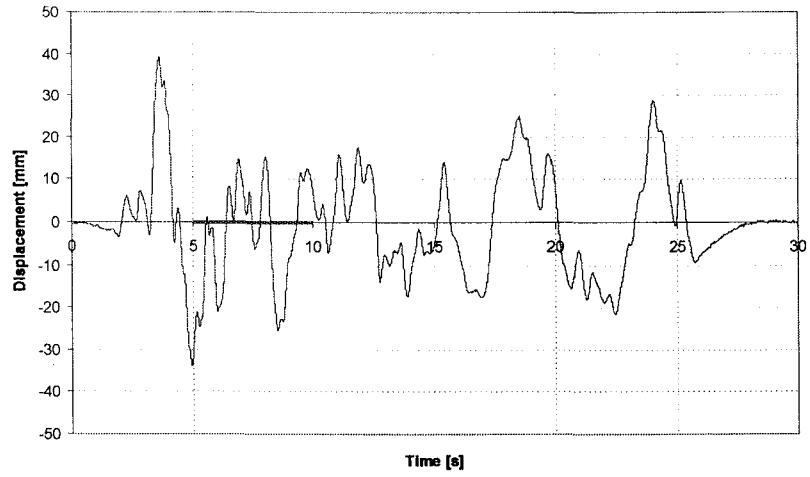
**Figure 66:** Top NS acceleration (A8).



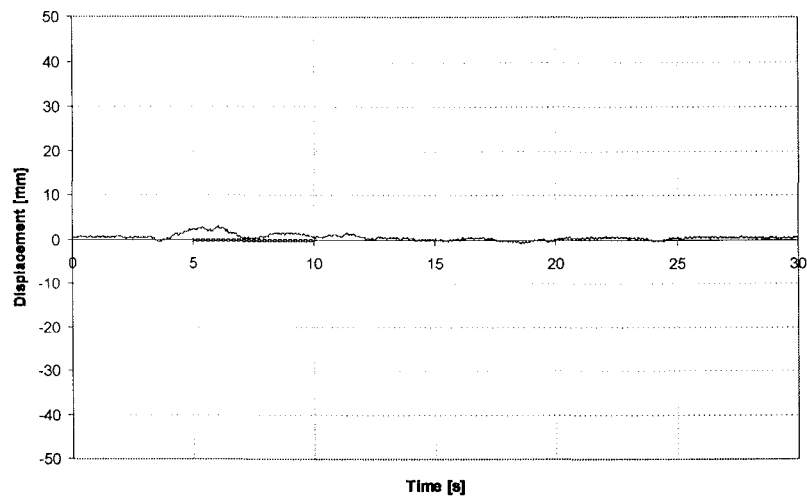
**Figure 67:** Top vertical acceleration (A9).



**Figure 68:** Mass displacement (D1).



**Figure 69:** EW displacement in shaking table (D2).

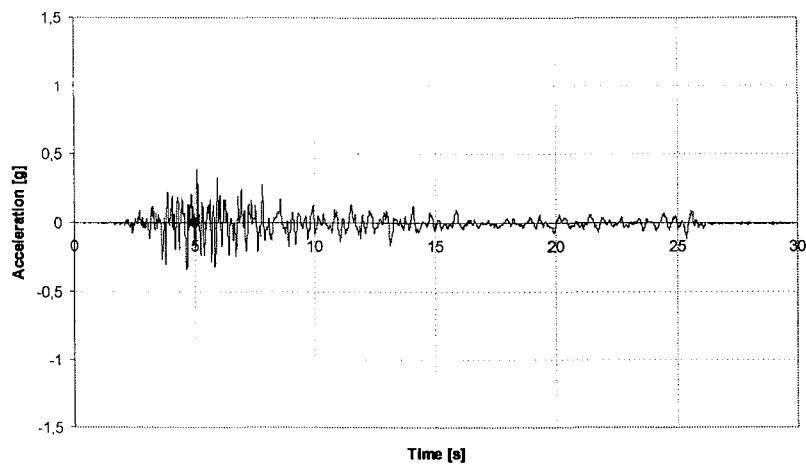


**Figure 70:** NS Displacement in shaking table (D3).

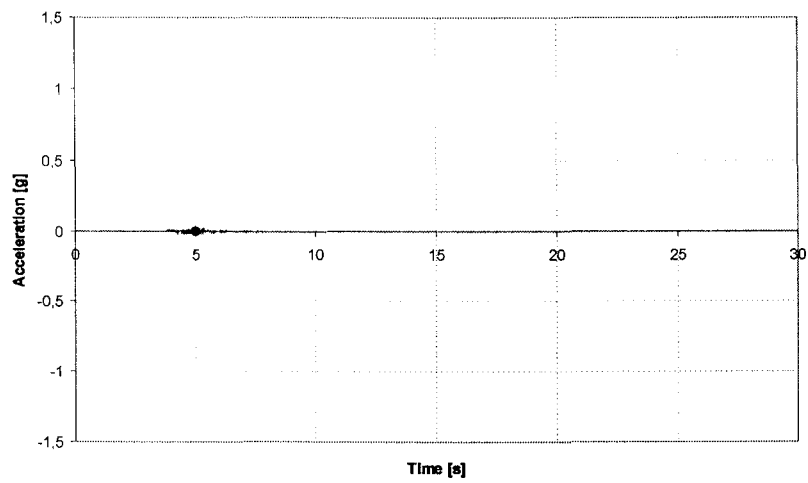


**Test 6 – PGA=0.4g with a 0.1 seconds discharge**

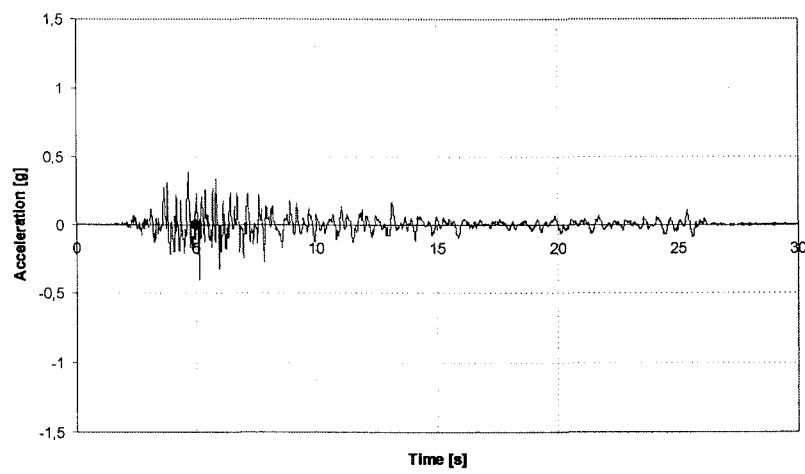




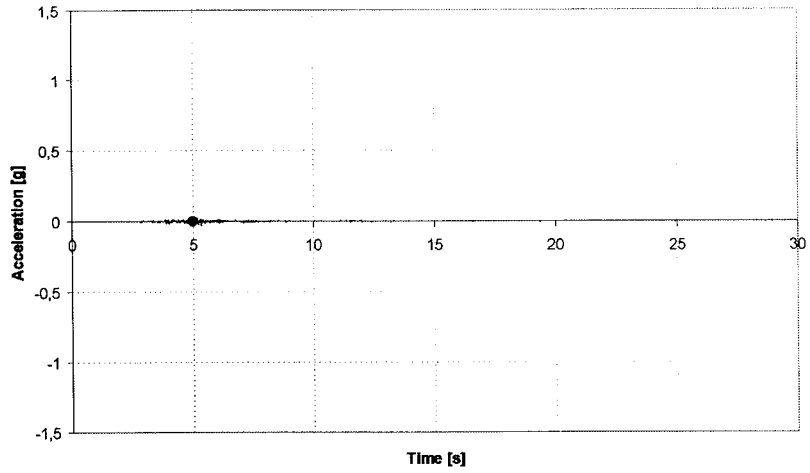
**Figure 71:** EW acceleration in shaking table.



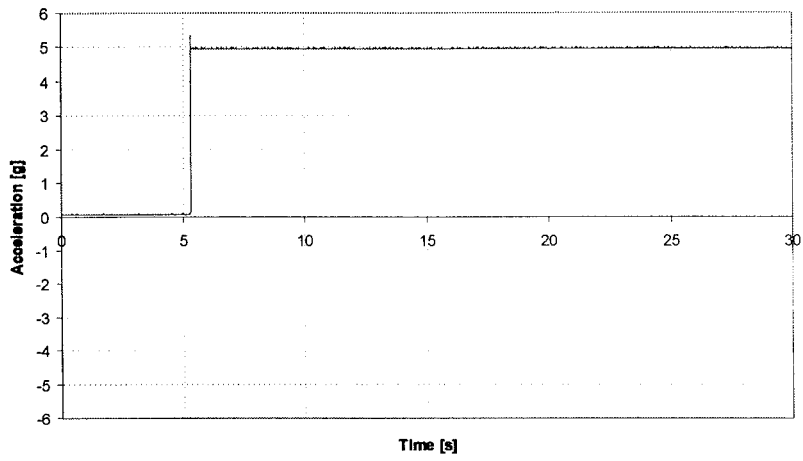
**Figure 72:** NS acceleration in shaking table.



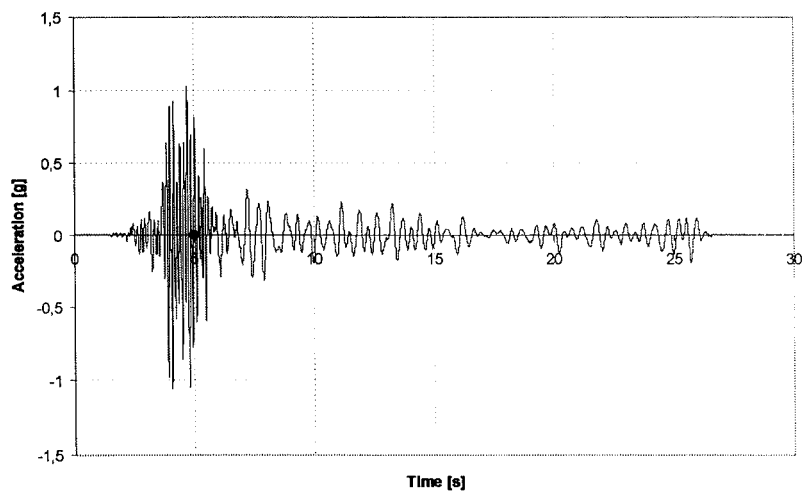
**Figure 73:** Bottom EW acceleration (A1).



**Figure 74:** Bottom NS Acceleration (A2).

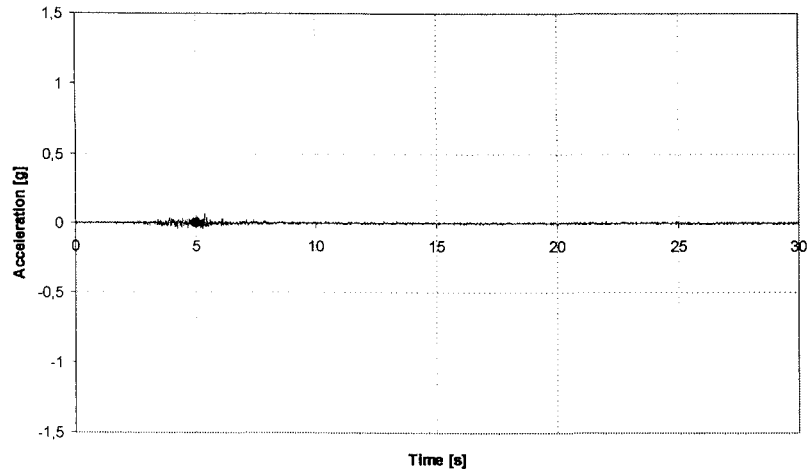


**Figure 75:** Air Bag Pressure Trigger.

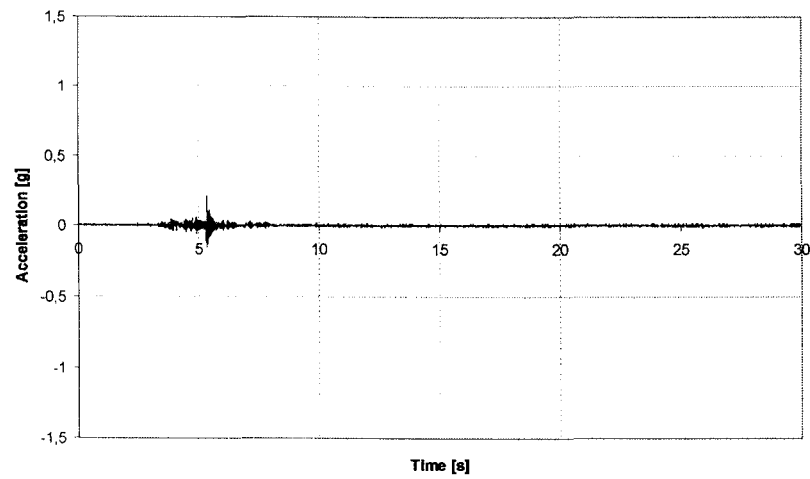


**Figure 76:** Mass EW acceleration (A4).

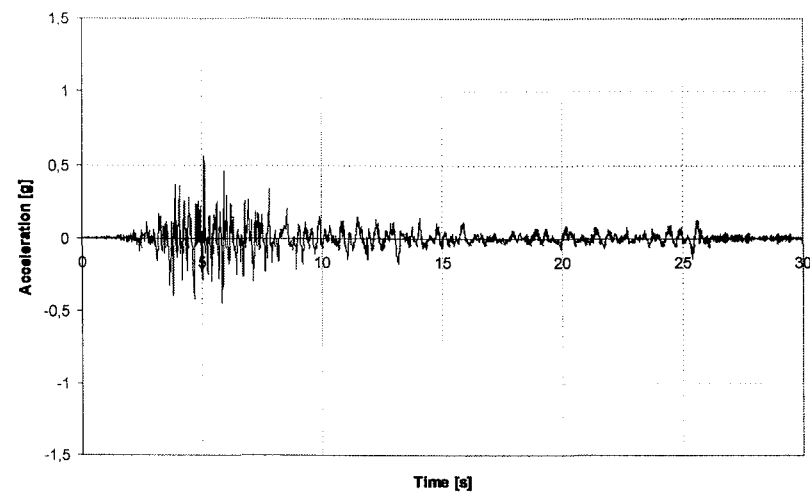




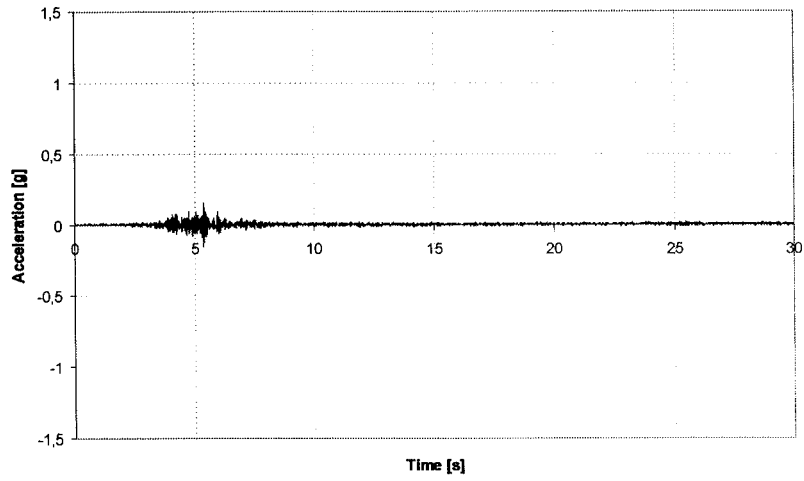
**Figure 77:** Mass NS acceleration (A5).



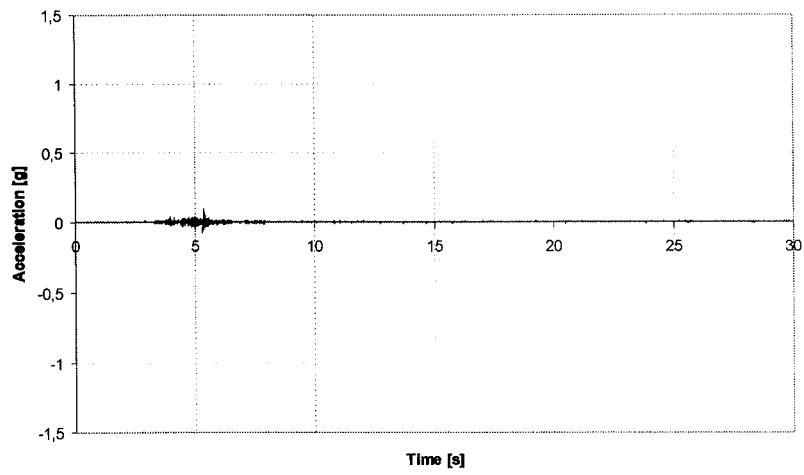
**Figure 78:** Mass vertical acceleration (A6).



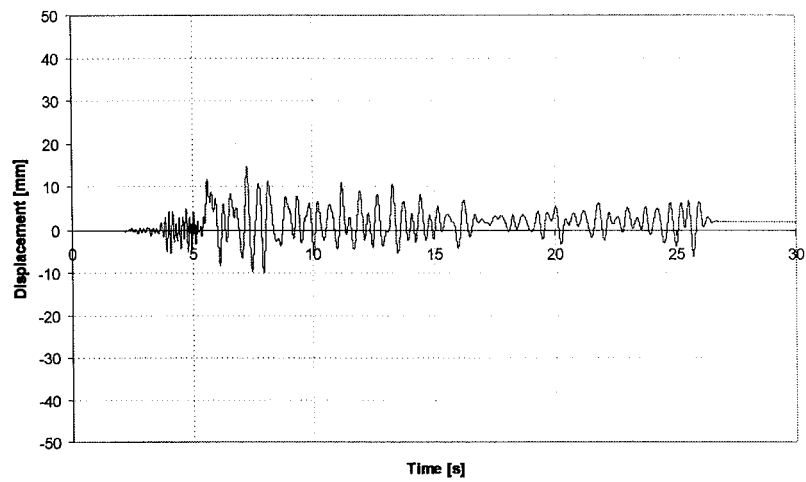
**Figure 79:** Top EW acceleration (A7).



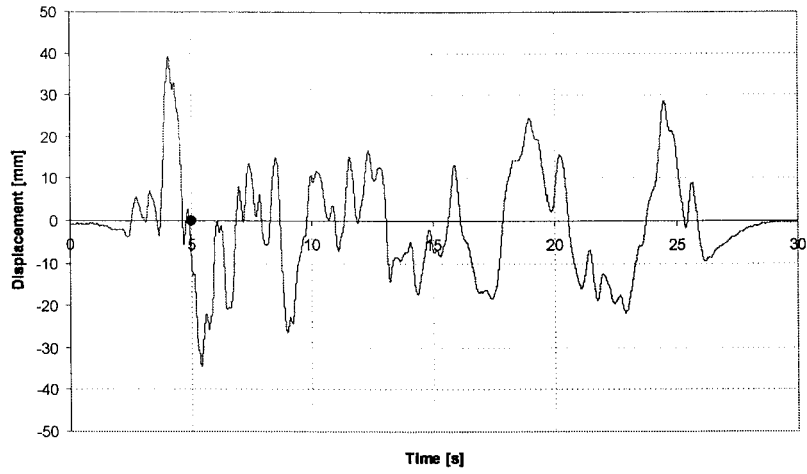
**Figure 80:** Top NS acceleration (A8).



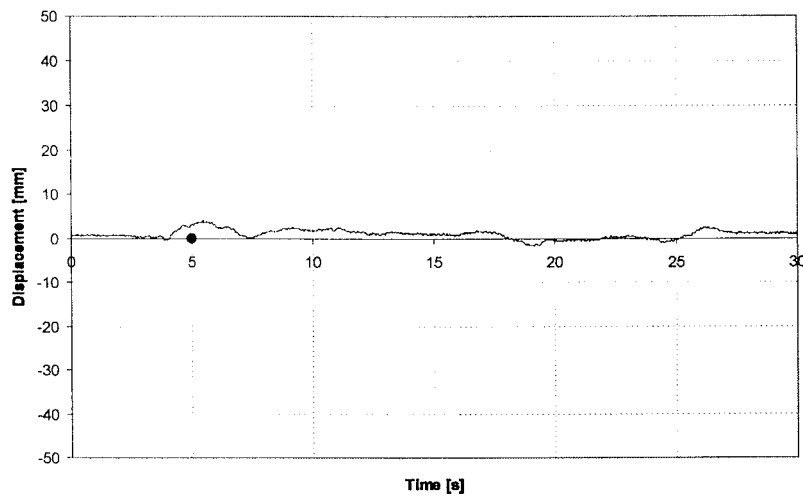
**Figure 81:** Top vertical acceleration (A9).



**Figure 82:** Mass displacement (D1).



**Figure 83:** EW displacement in shaking table (D2).

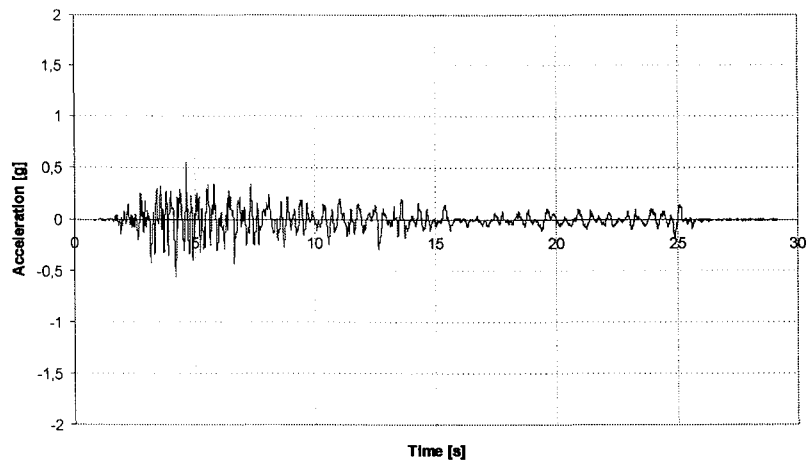


**Figure 84:** NS Displacement in shaking table (D3).

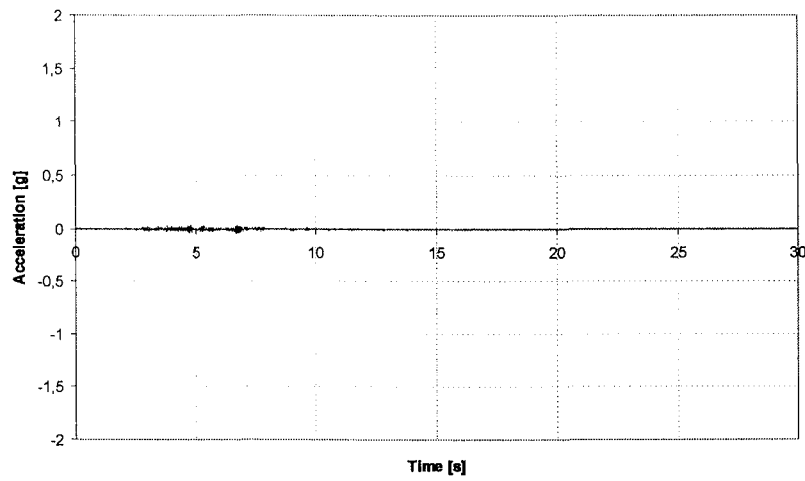


**Test 7 – PGA=0.6g without discharge**

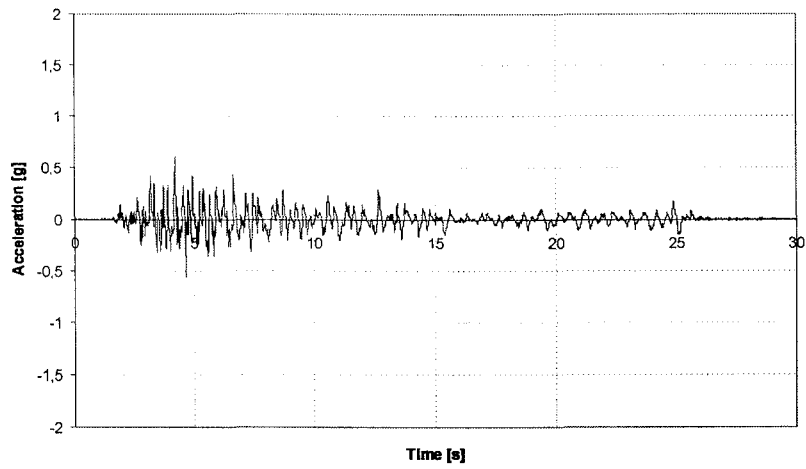




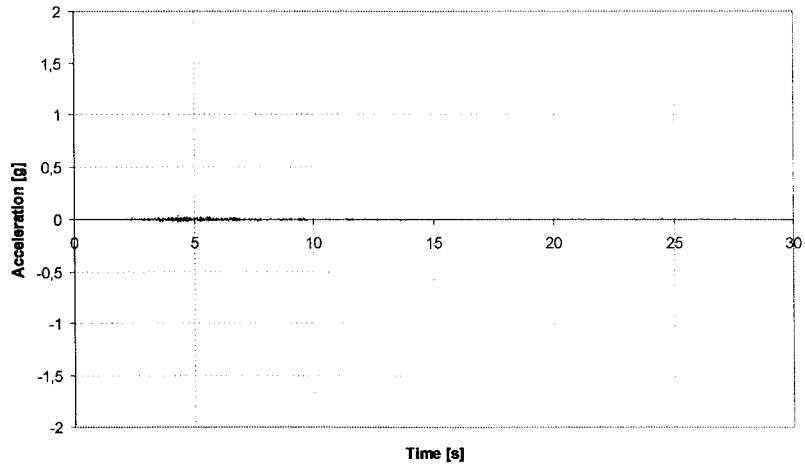
**Figure 85:** EW acceleration in shaking table.



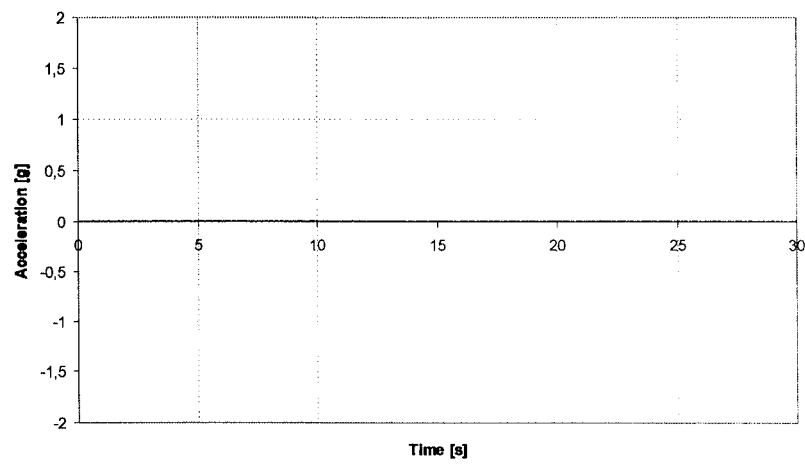
**Figure 86:** NS acceleration in shaking table.



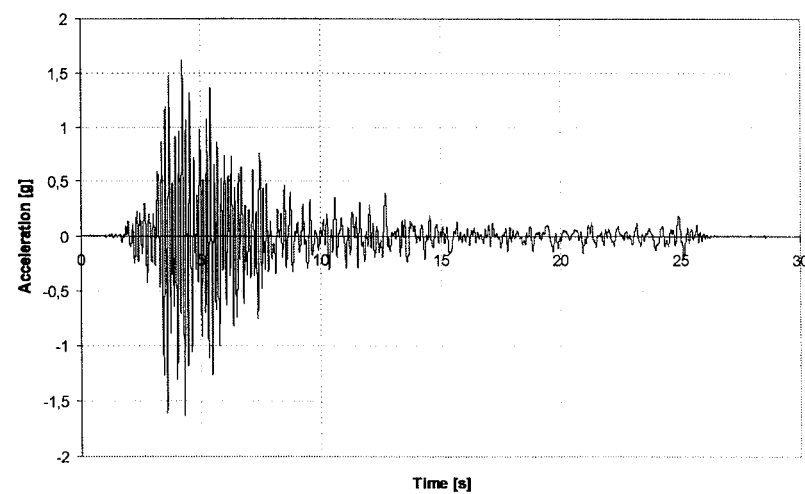
**Figure 87:** Bottom EW acceleration (A1).



**Figure 88:** Bottom NS Acceleration (A2).

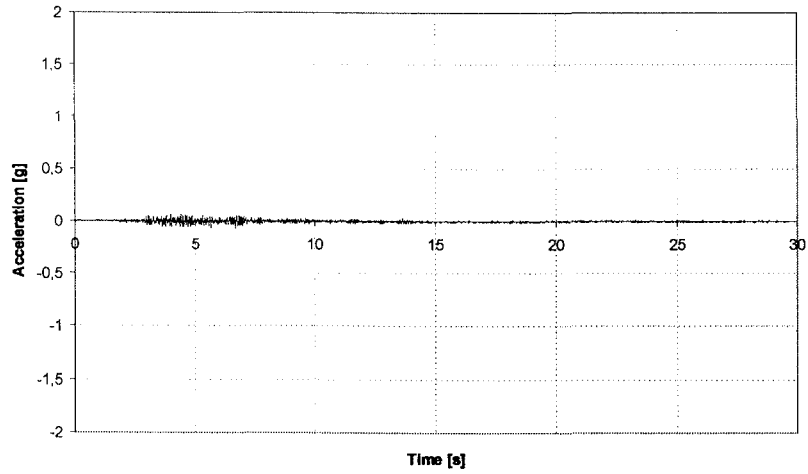


**Figure 89:** Air Bag Pressure Trigger.

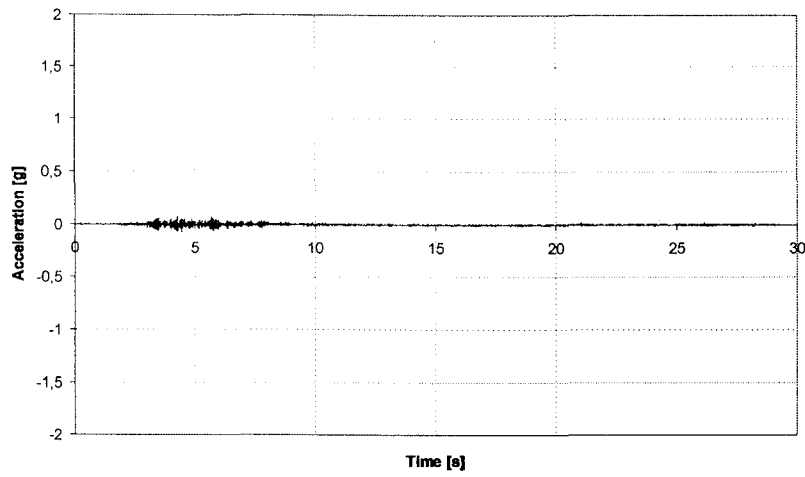


**Figure 90:** Mass EW acceleration (A4).

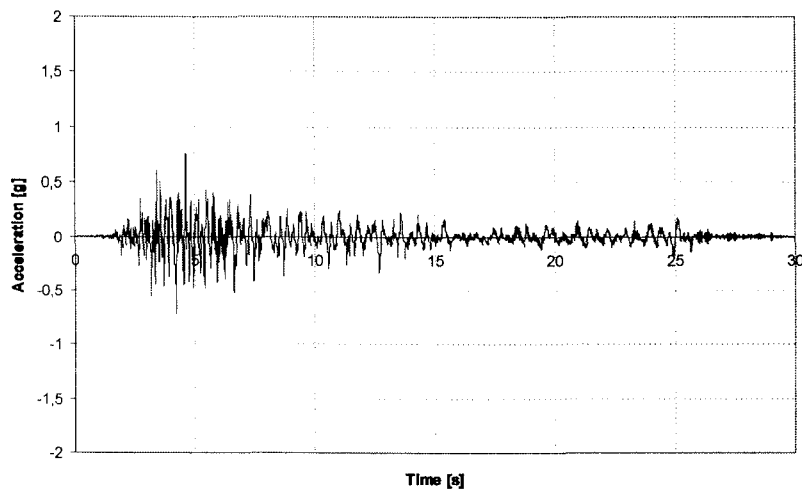




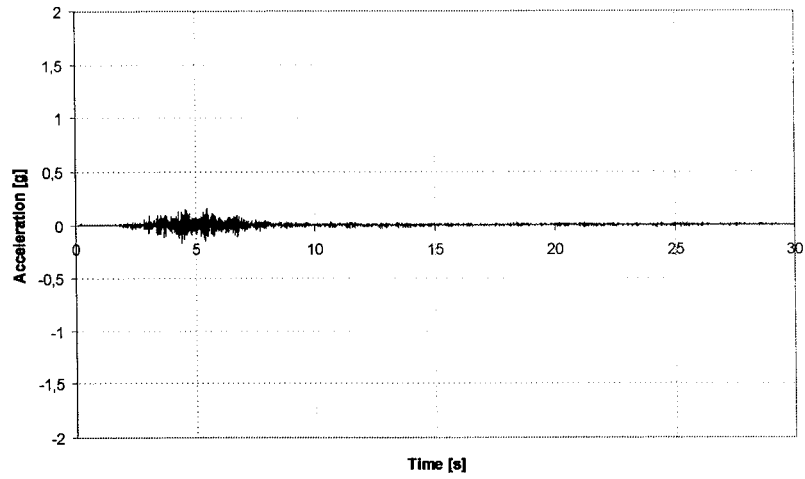
**Figure 91:** Mass NS acceleration (A5).



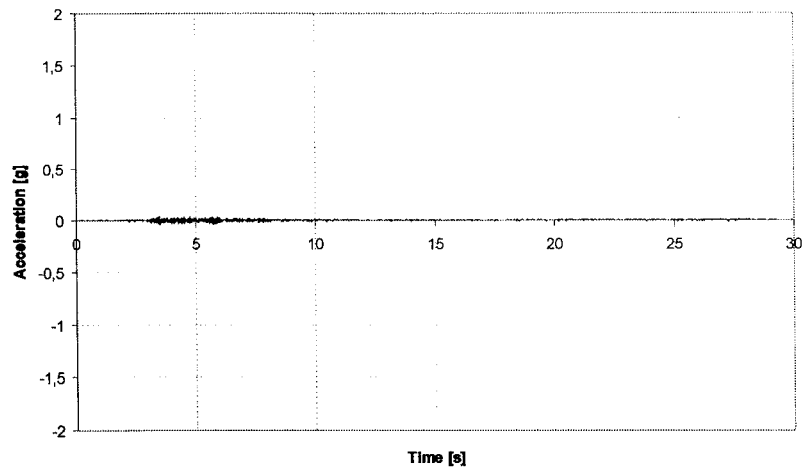
**Figure 92:** Mass vertical acceleration (A6).



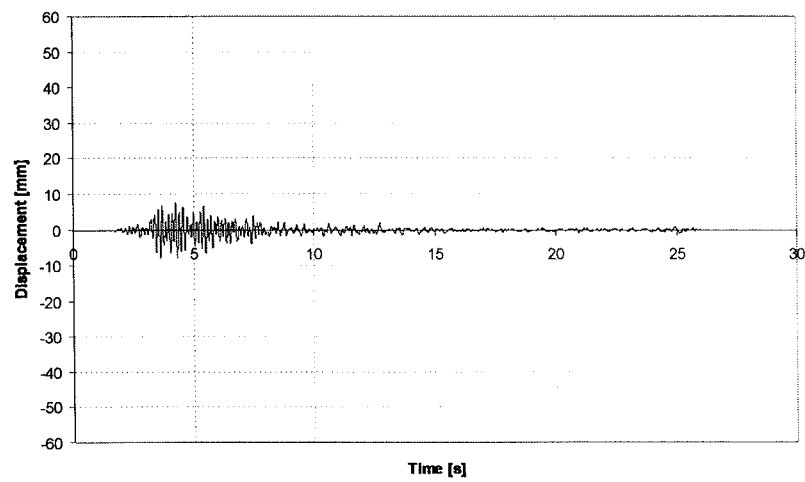
**Figure 93:** Top EW acceleration (A7).



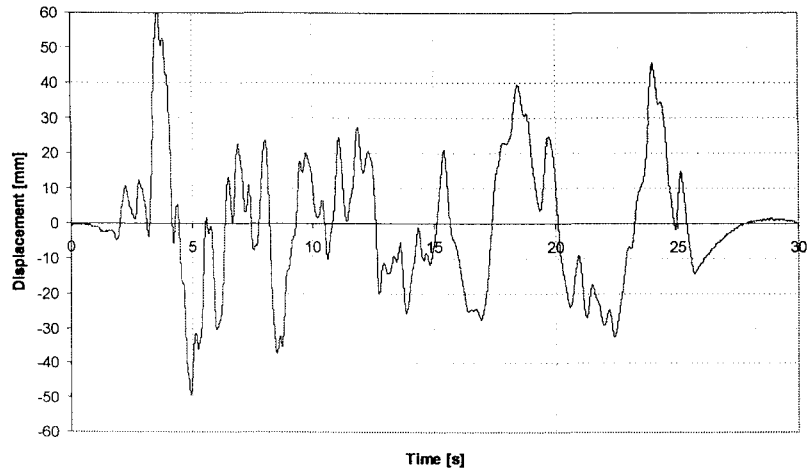
**Figure 94:** Top NS acceleration (A8).



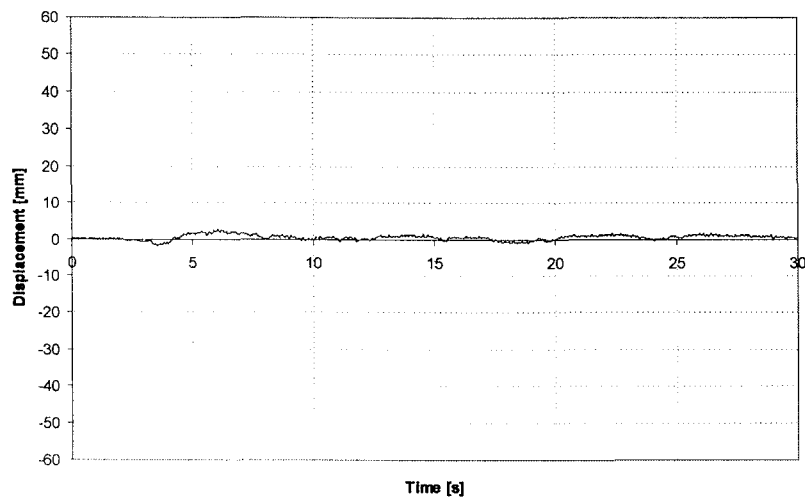
**Figure 95:** Top vertical acceleration (A9).



**Figure 96:** Mass displacement (D1).



**Figure 97:** EW displacement in shaking table (D2).

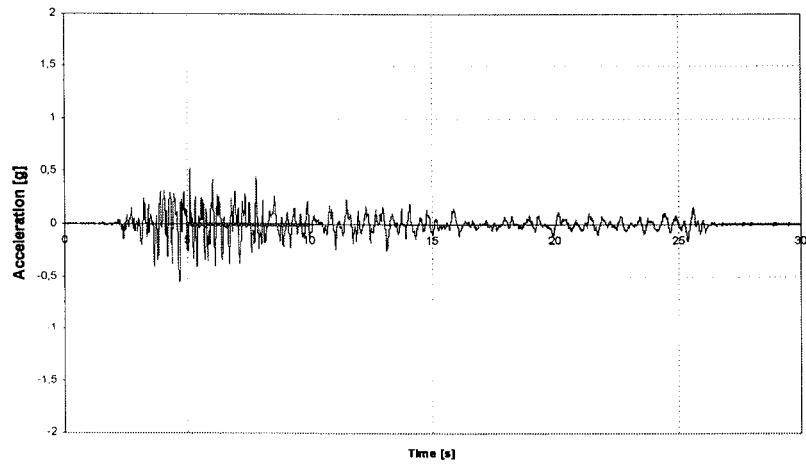


**Figure 98:** NS Displacement in shaking table (D3).

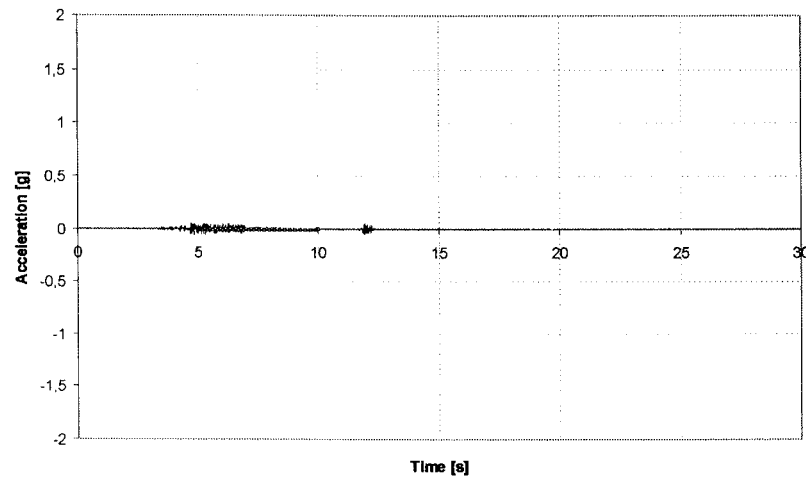


**Test 8 – PGA=0.6g with a 5 seconds discharge**

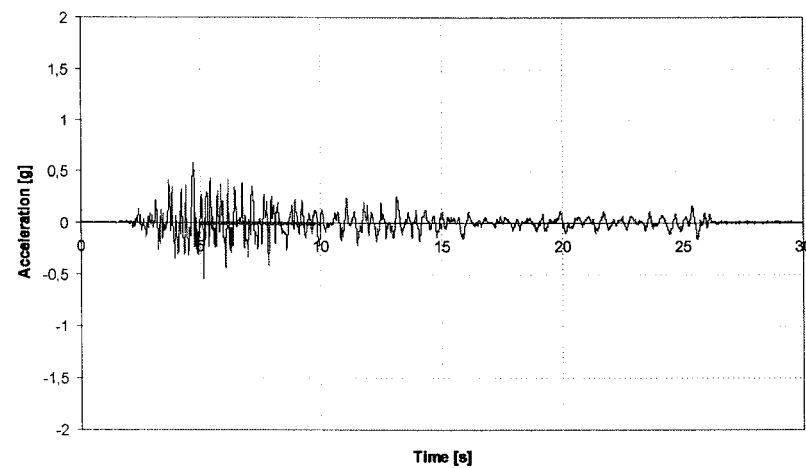




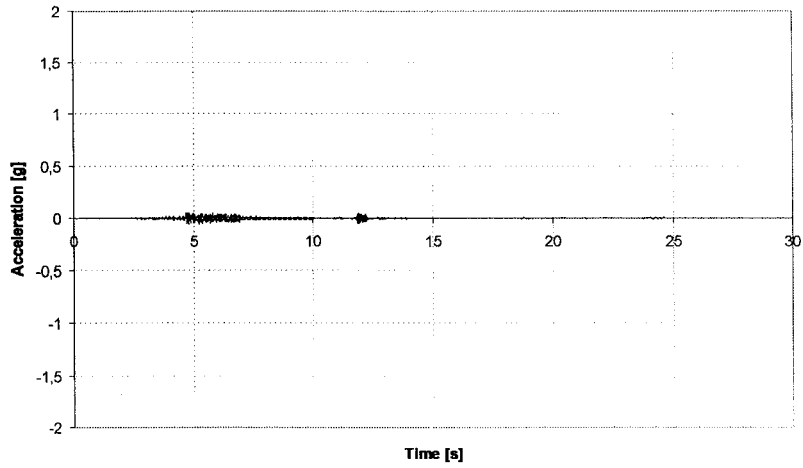
**Figure 99:** EW acceleration in shaking table.



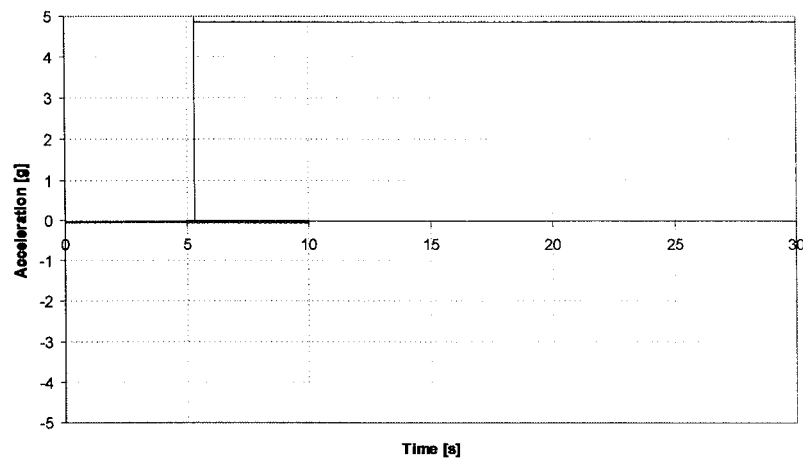
**Figure 100:** NS acceleration in shaking table.



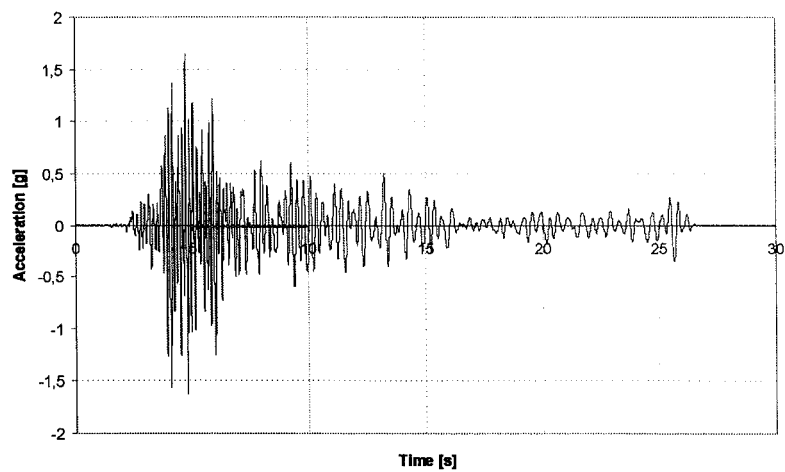
**Figure 101:** Bottom EW acceleration (A1).



**Figure 102:** Bottom NS Acceleration (A2).

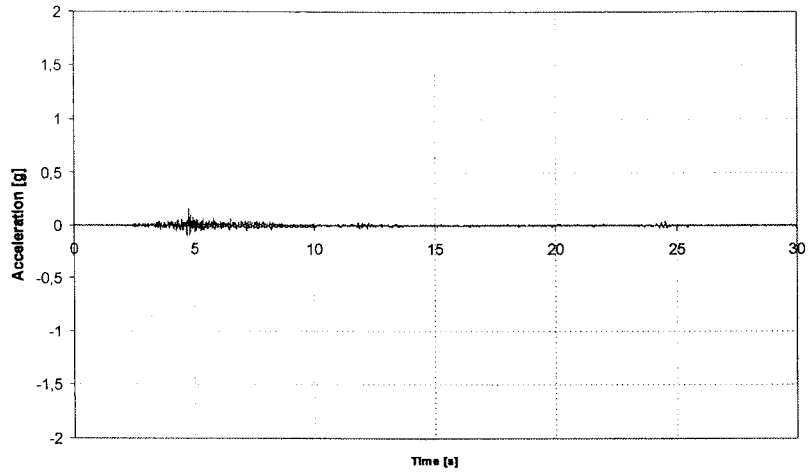


**Figure 103:** Air Bag Pressure Trigger.

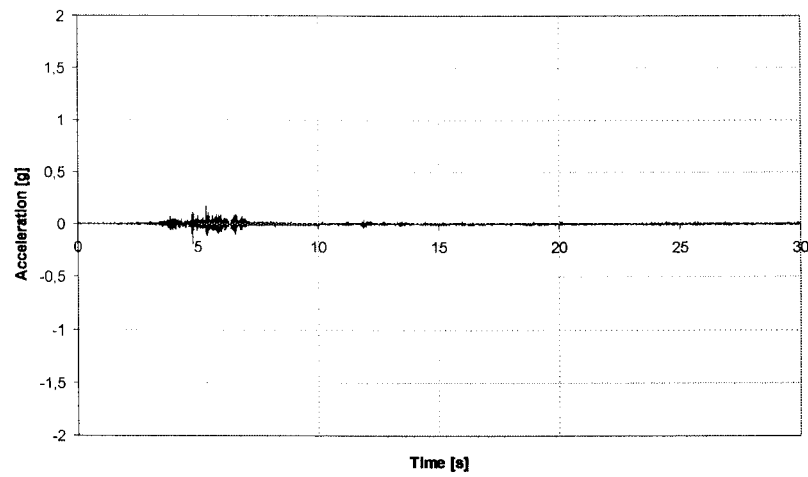


**Figure 104:** Mass EW acceleration (A4).

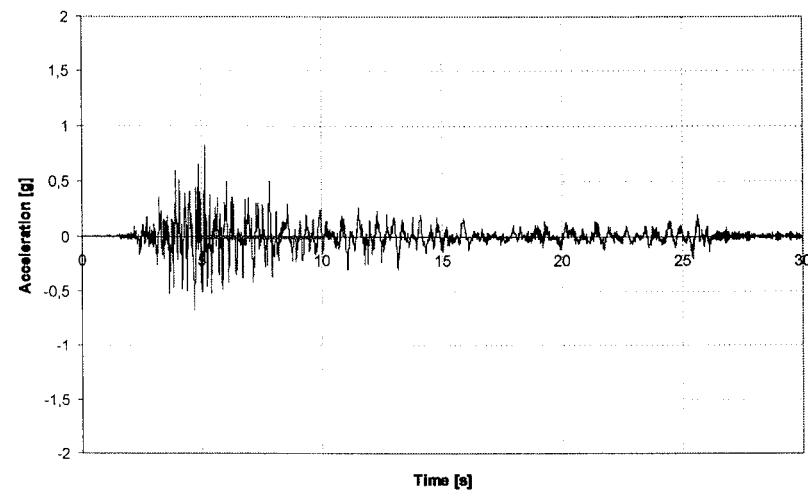




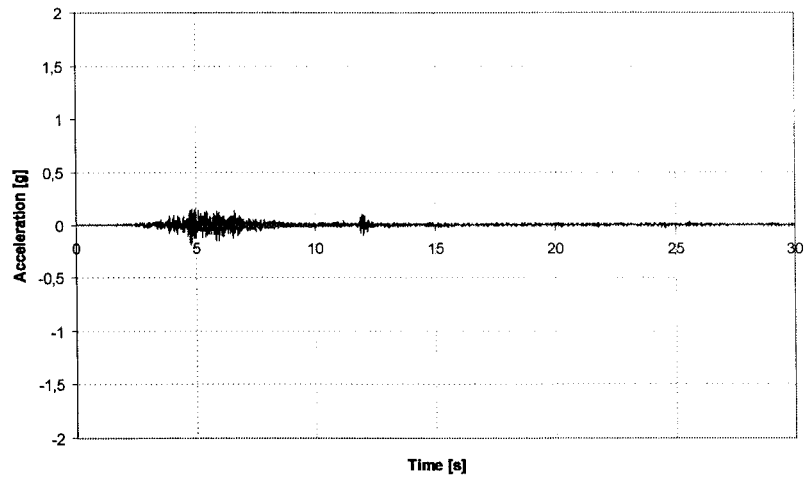
**Figure 105:** Mass NS acceleration (A5).



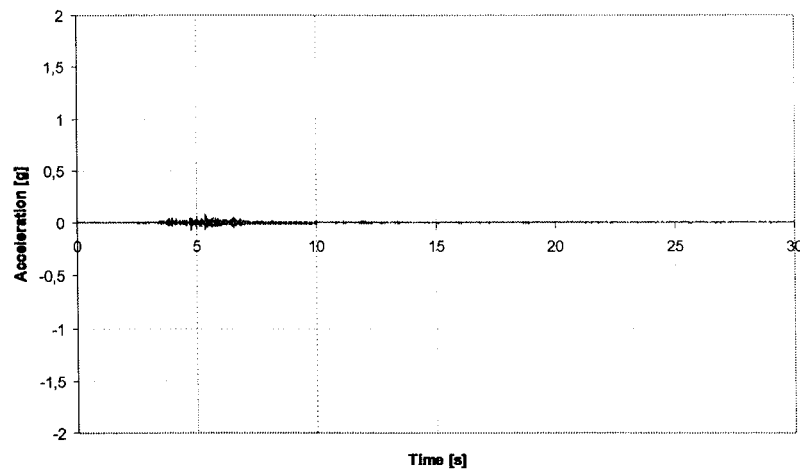
**Figure 106:** Mass vertical acceleration (A6).



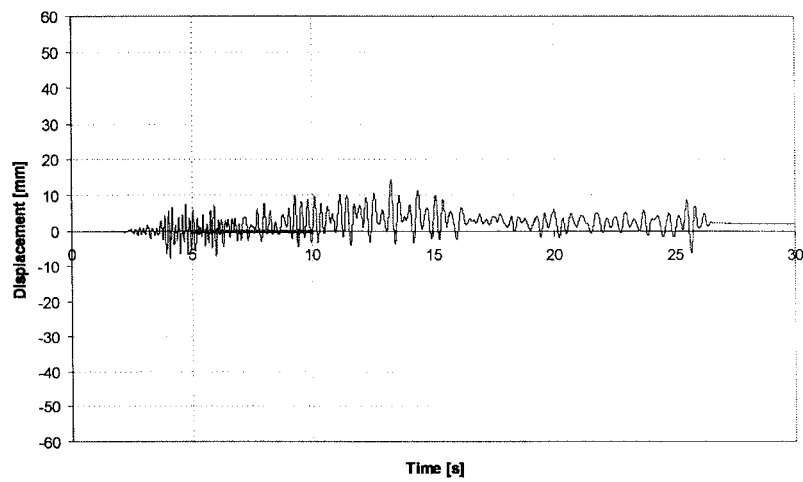
**Figure 107:** Top EW acceleration (A7).



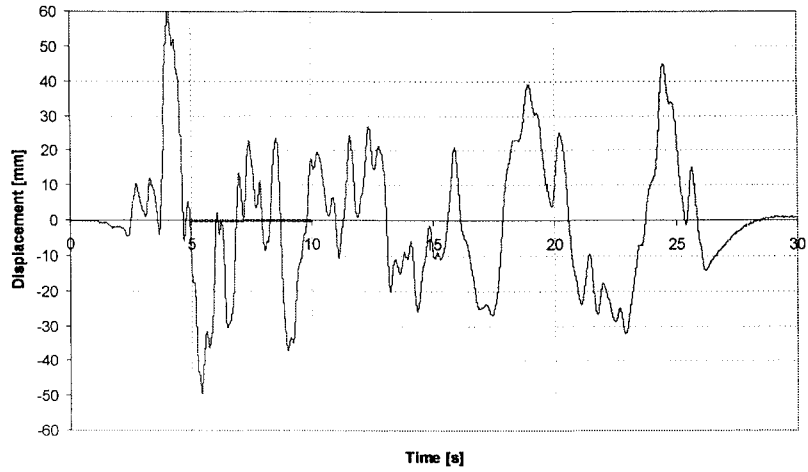
**Figure 108:** Top NS acceleration (A8).



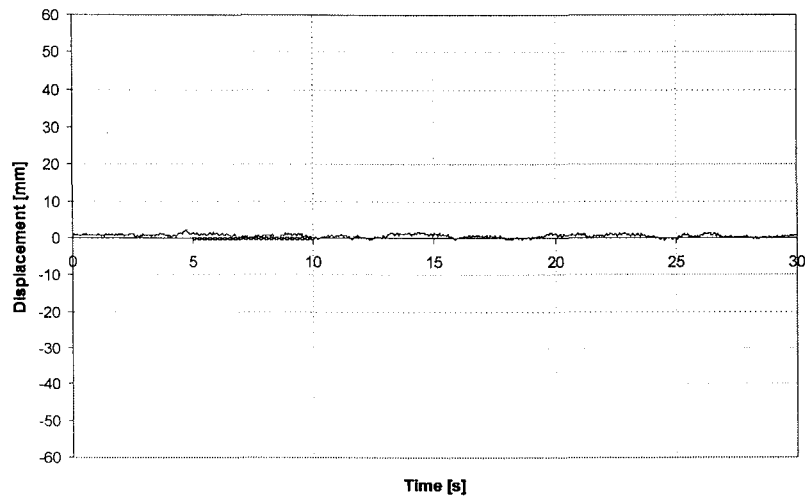
**Figure 109:** Top vertical acceleration (A9).



**Figure 110:** Mass displacement (D1).



**Figure 111:** EW displacement in shaking table (D2).

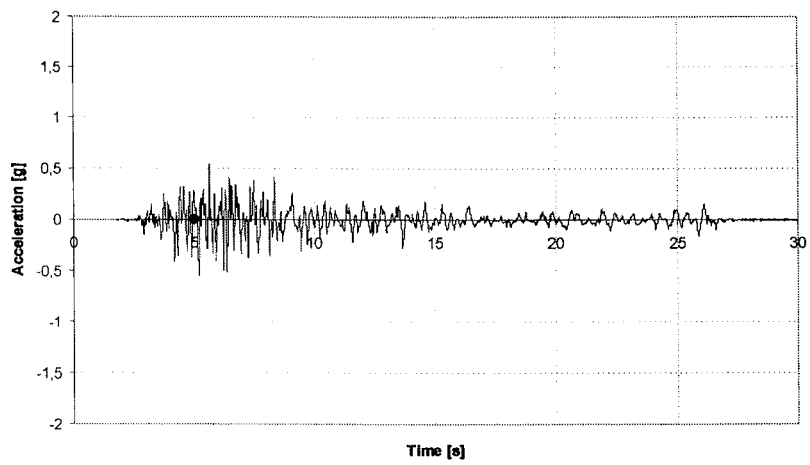


**Figure 112:** NS Displacement in shaking table (D3).

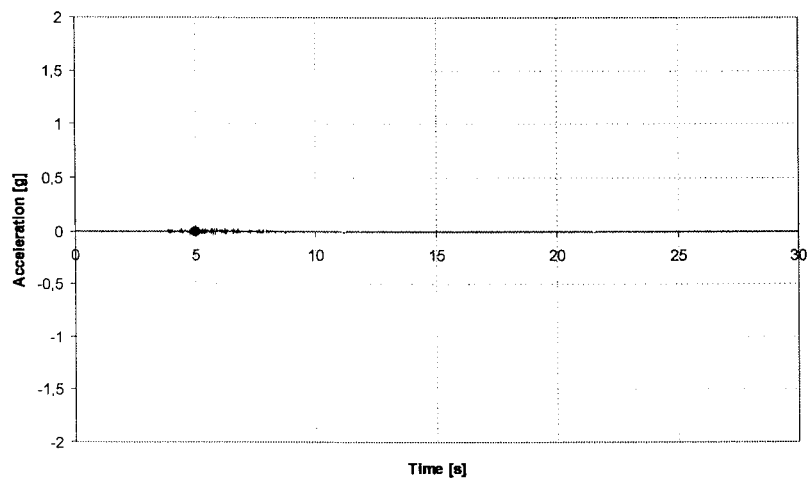


**Test 9 – PGA=0.6g with a 0.1 seconds discharge**

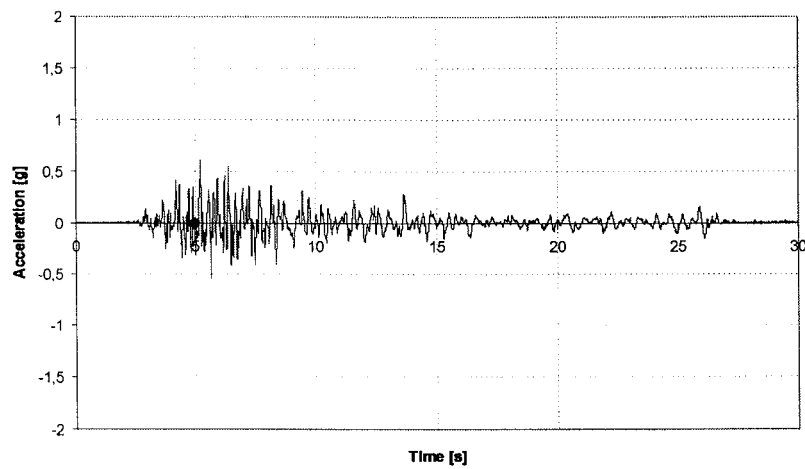




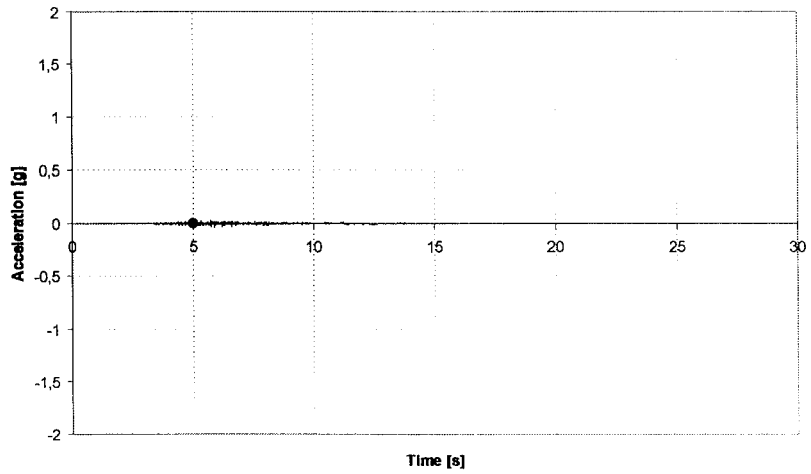
**Figure 113:** EW acceleration in shaking table.



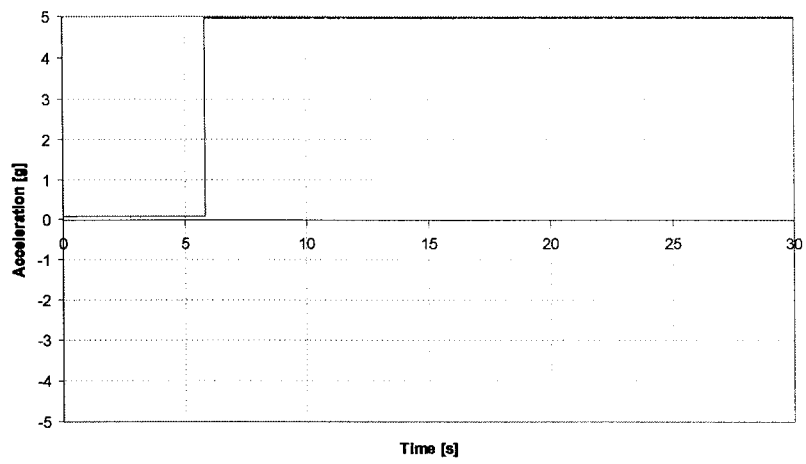
**Figure 114:** NS acceleration in shaking table.



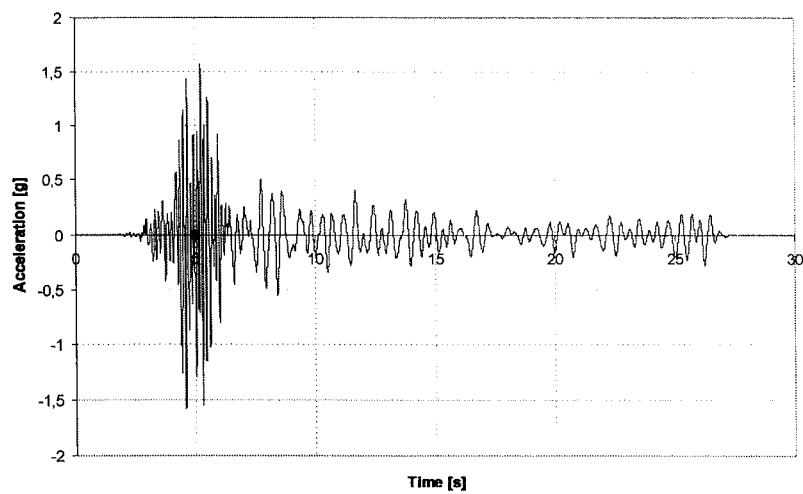
**Figure 115:** Bottom EW acceleration (A1).



**Figure 116:** Bottom NS Acceleration (A2).

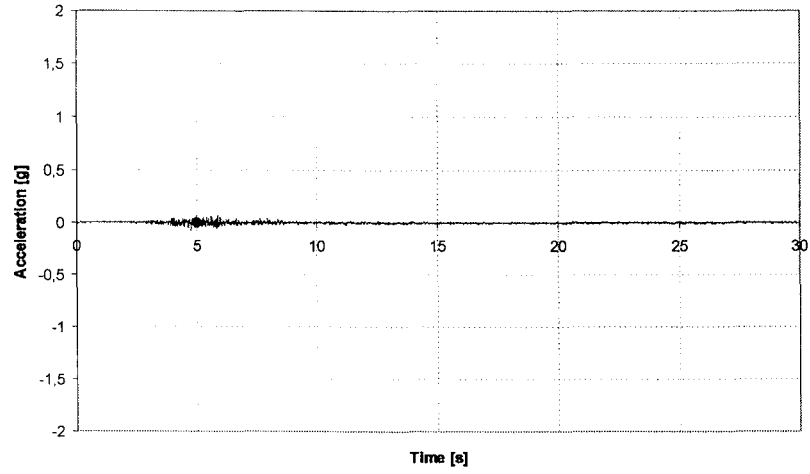


**Figure 117:** Air Bag Pressure Trigger.

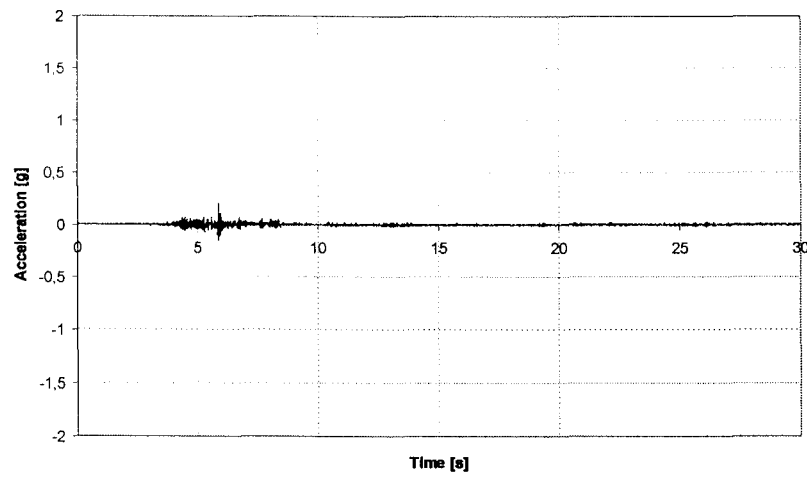


**Figure 118:** Mass EW acceleration (A4).

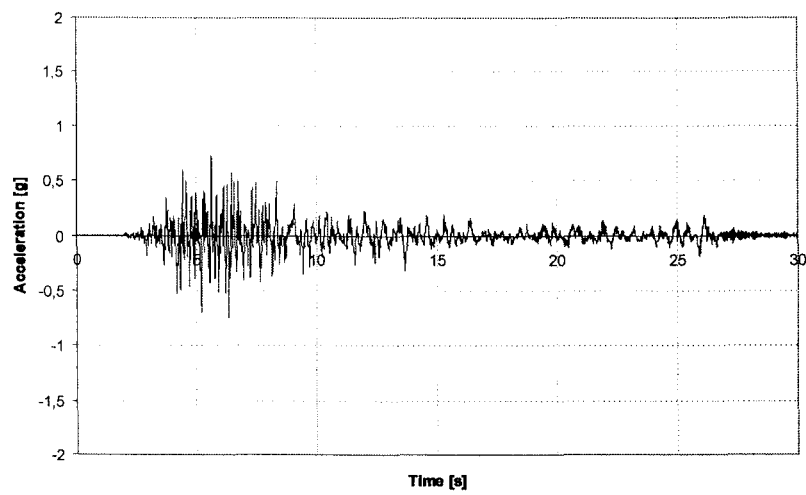




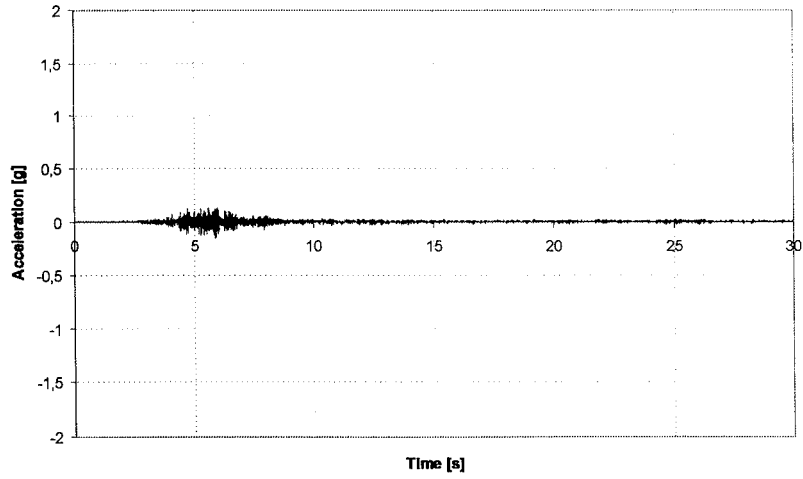
**Figure 119:** Mass NS acceleration (A5).



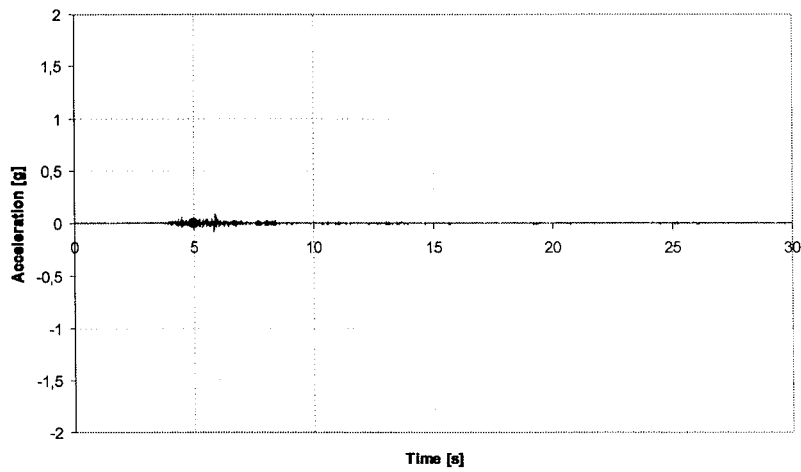
**Figure 120:** Mass vertical acceleration (A6).



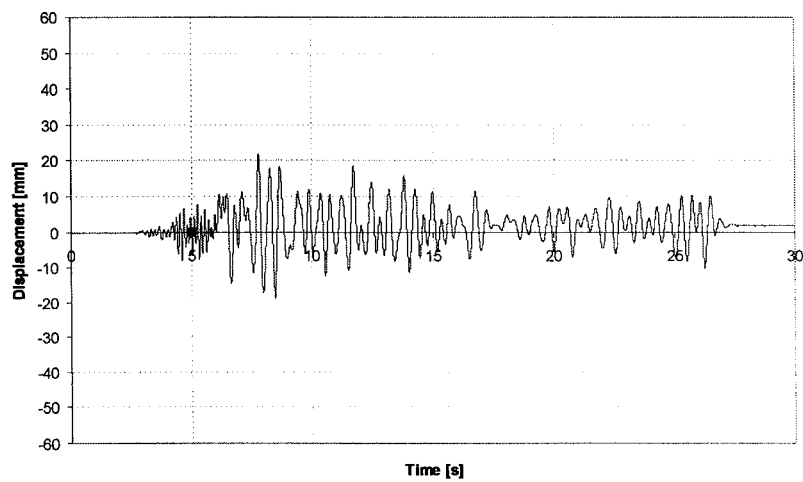
**Figure 121:** Top EW acceleration (A7).



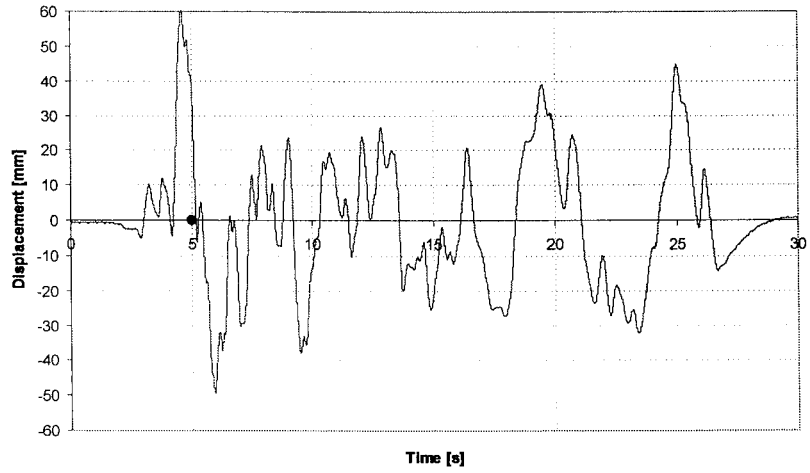
**Figure 122:** Top NS acceleration (A8).



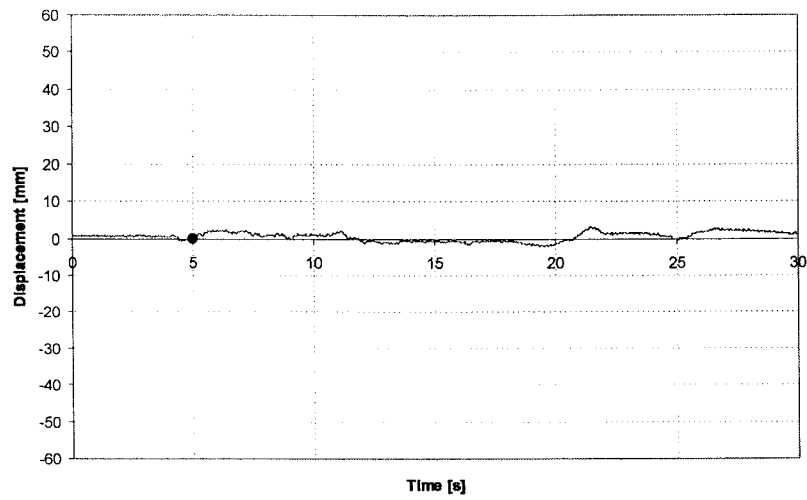
**Figure 123:** Top vertical acceleration (A9).



**Figure 124:** Mass displacement (D1).



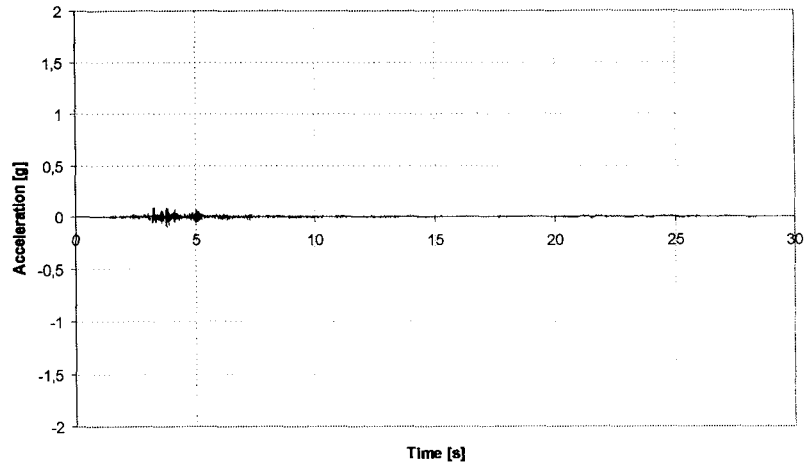
**Figure 125:** EW displacement in shaking table (D2).



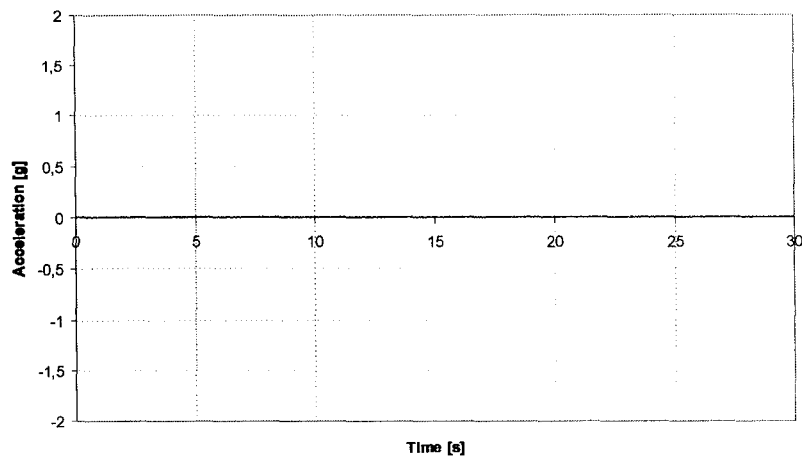
**Figure 126:** NS Displacement in shaking table (D3).



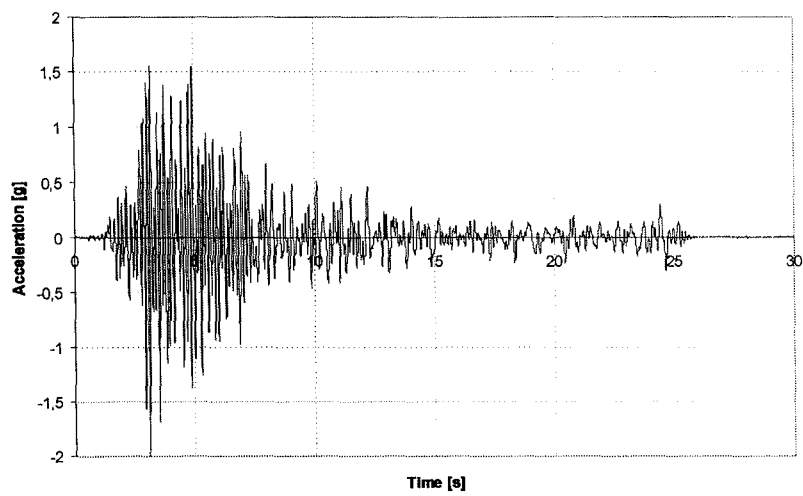
**Test 10 – PGA=0.8g without discharge**



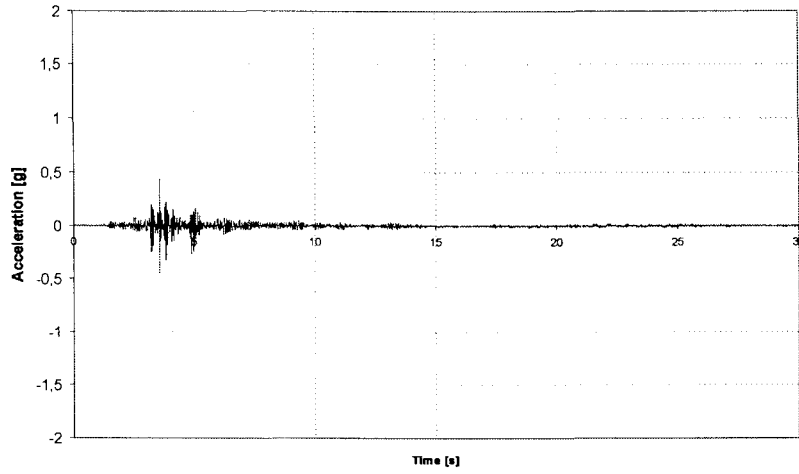
**Figure 130:** Bottom NS Acceleration (A2).



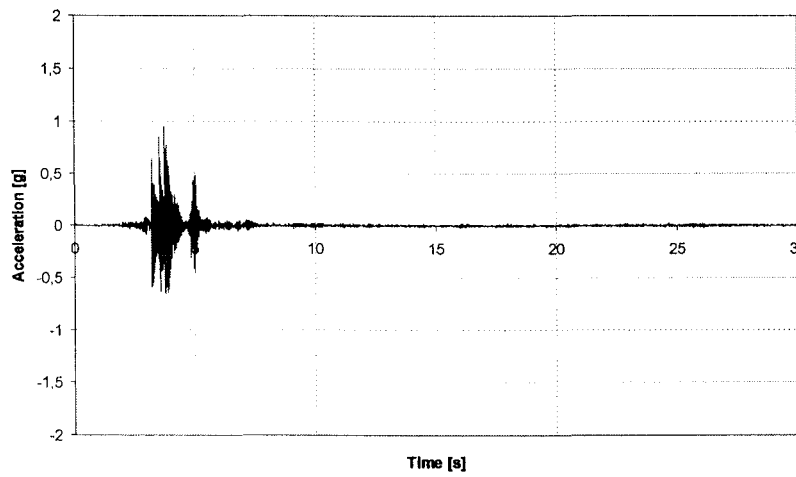
**Figure 131:** Air Bag Pressure Trigger.



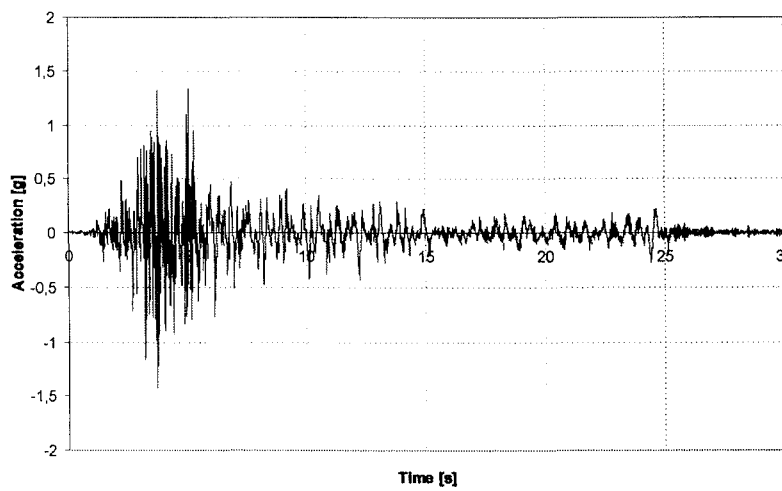
**Figure 132:** Mass EW acceleration (A4).



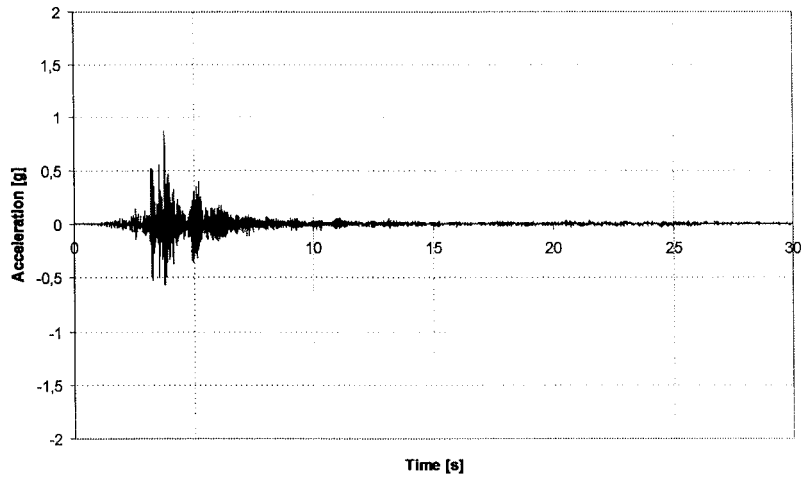
**Figure 133:** Mass NS acceleration (A5).



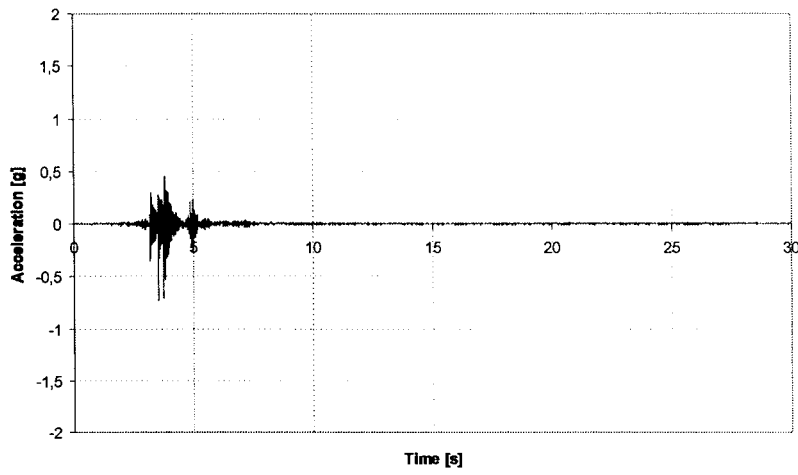
**Figure 134:** Mass vertical acceleration (A6).



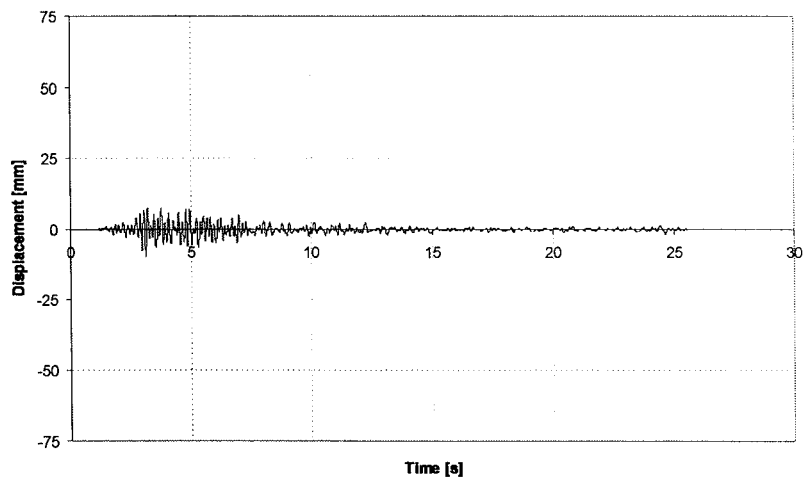
**Figure 135:** Top EW acceleration (A7).



**Figure 136:** Top NS acceleration (A8).

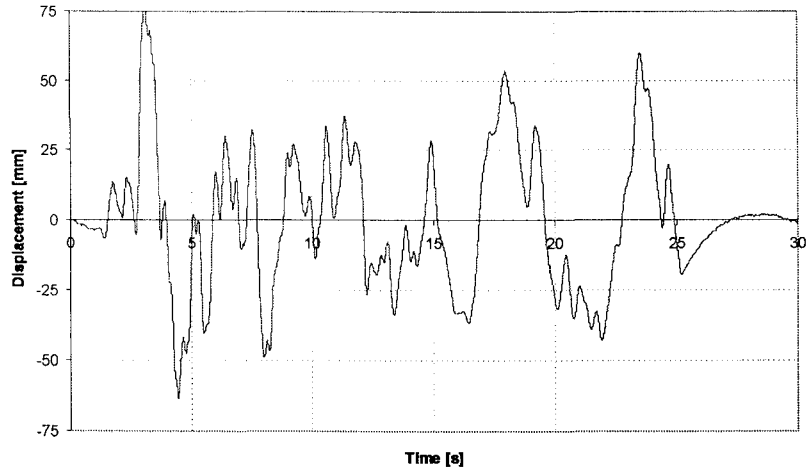


**Figure 137:** Top vertical acceleration (A9).

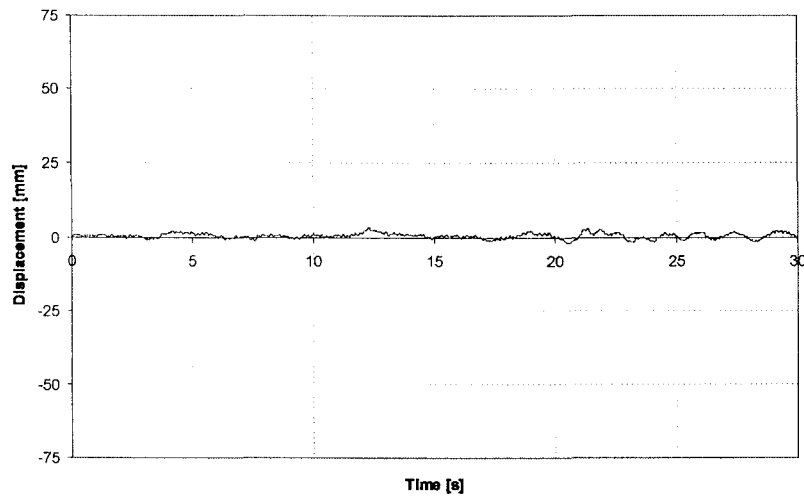


**Figure 138:** Mass displacement (D1).





**Figure 139:** EW displacement in shaking table (D2).

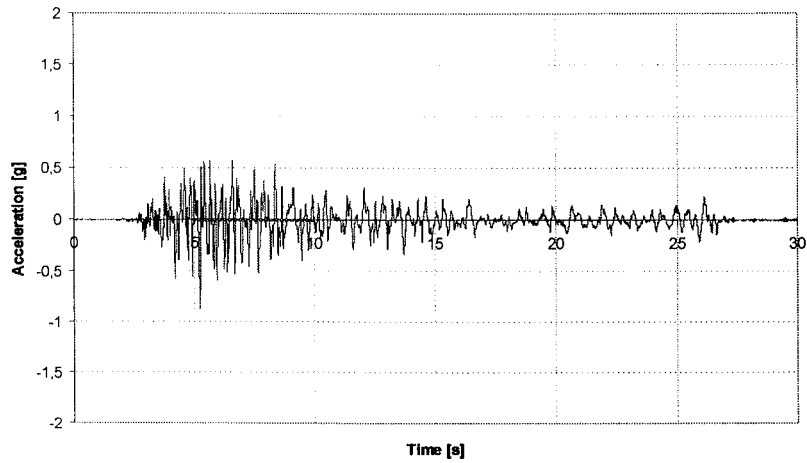


**Figure 140:** NS Displacement in shaking table (D3).

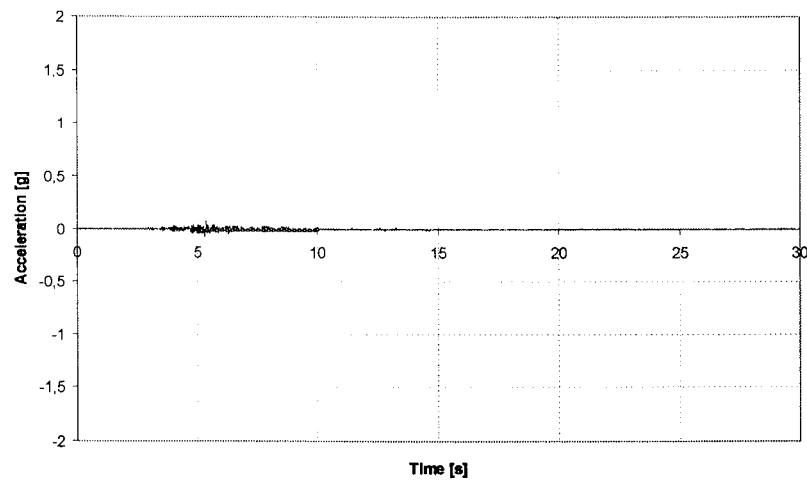


**Test 11 – PGA=0.8g with a 5 seconds discharge**

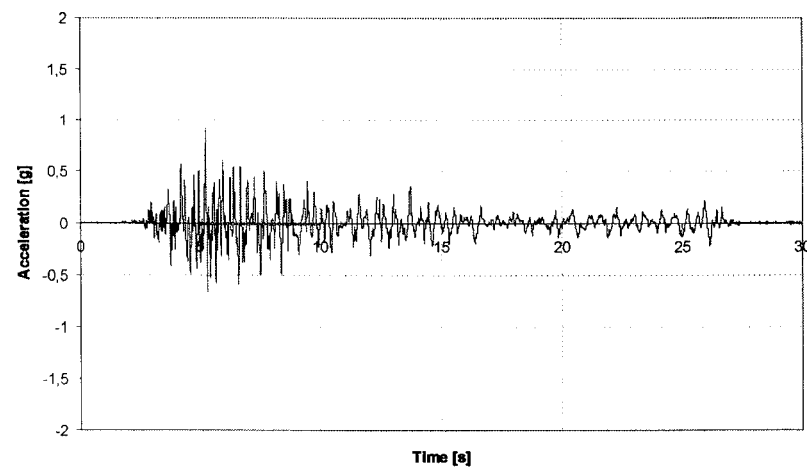




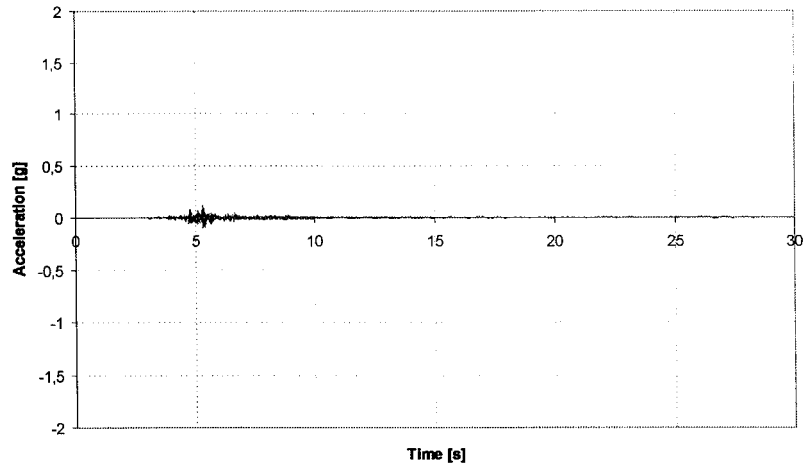
**Figure 141:** EW acceleration in shaking table.



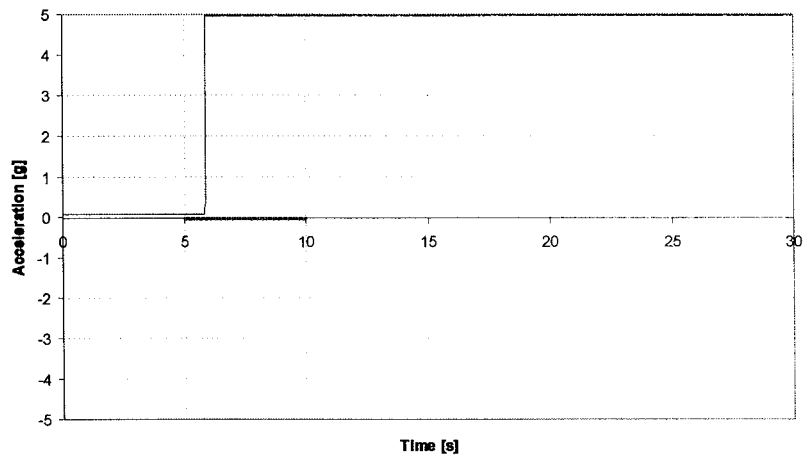
**Figure 142:** NS acceleration in shaking table.



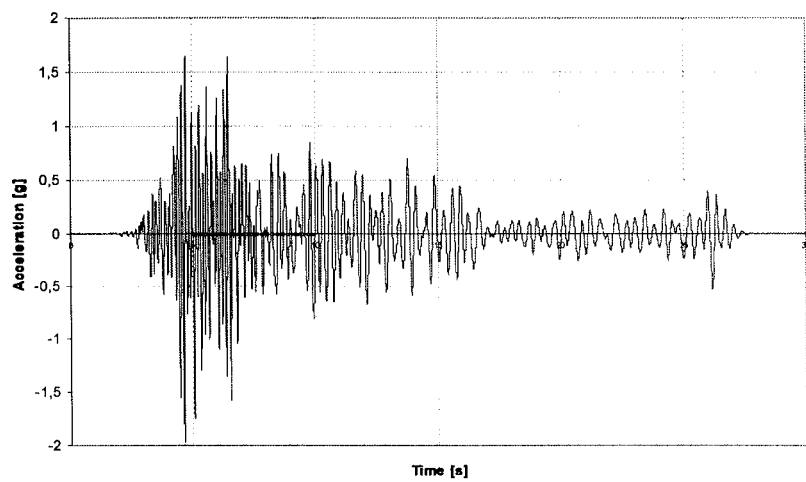
**Figure 143:** Bottom EW acceleration (A1).



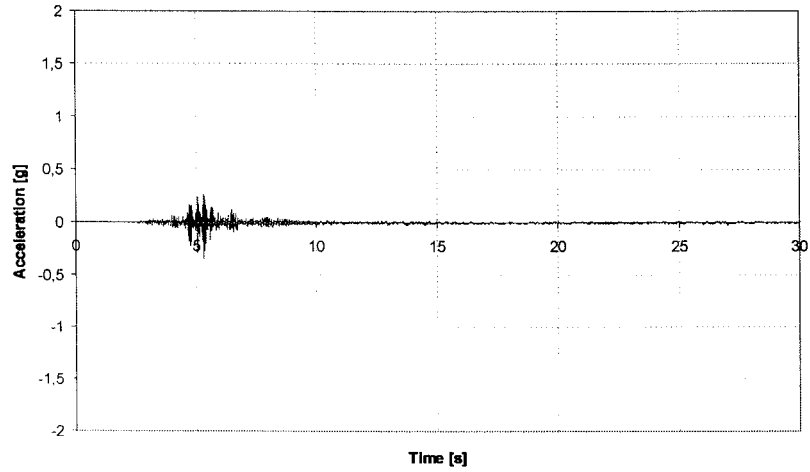
**Figure 144:** Bottom NS Acceleration (A2).



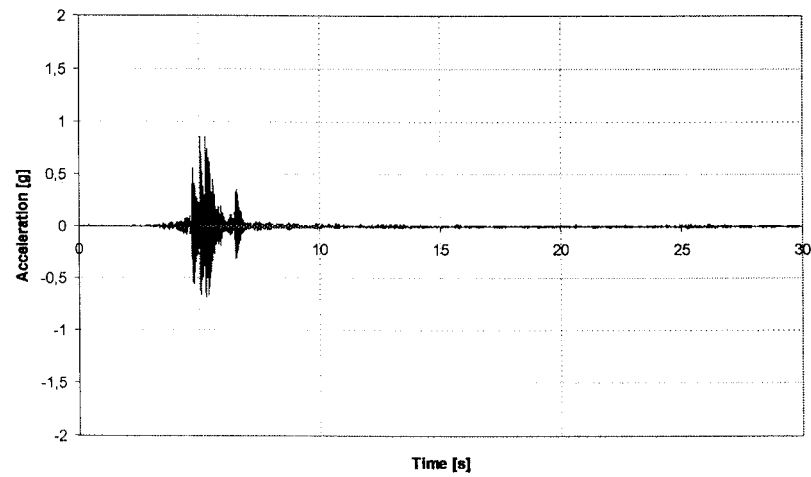
**Figure 145:** Air Bag Pressure Trigger.



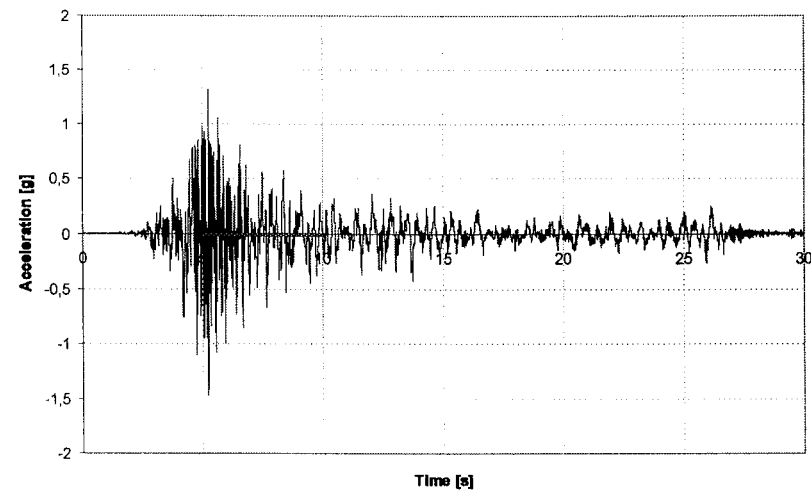
**Figure 146:** Mass EW acceleration (A4).



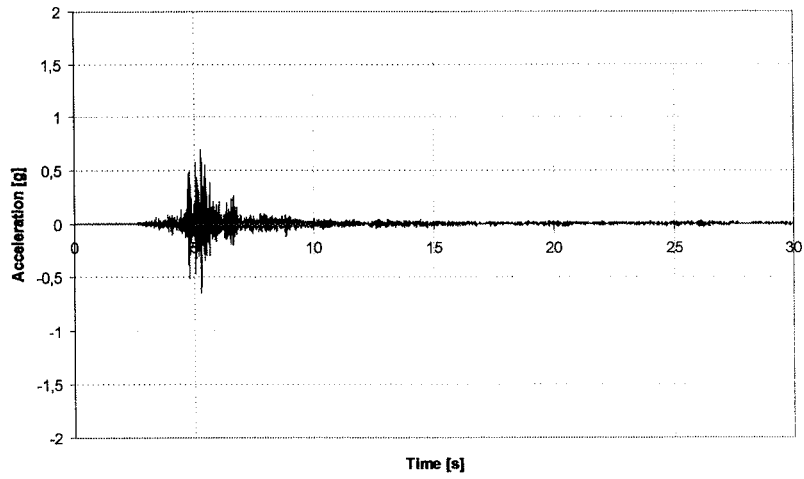
**Figure 147:** Mass NS acceleration (A5).



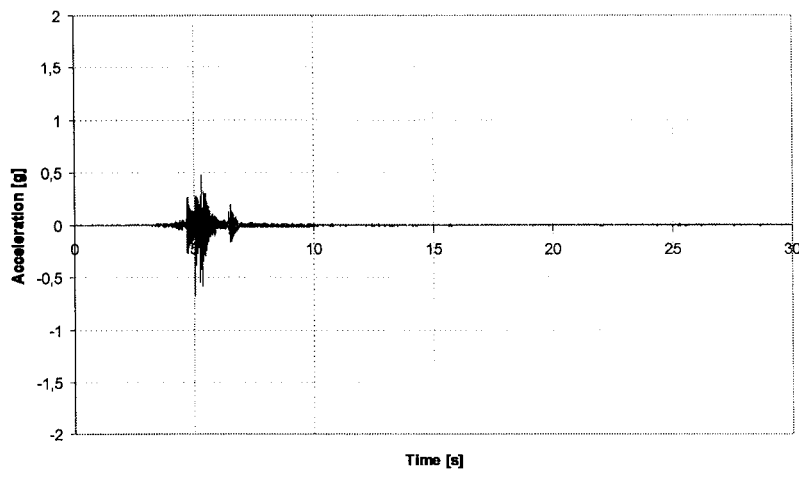
**Figure 148:** Mass vertical acceleration (A6).



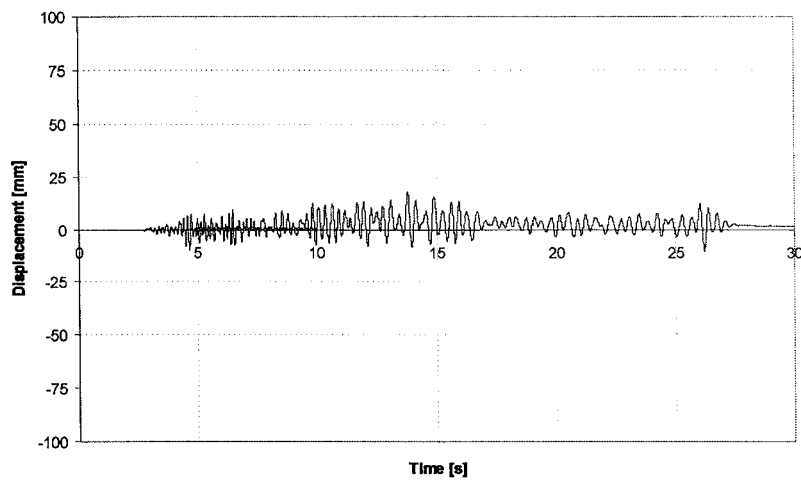
**Figure 149:** Top EW acceleration (A7).



**Figure 150:** Top NS acceleration (A8).

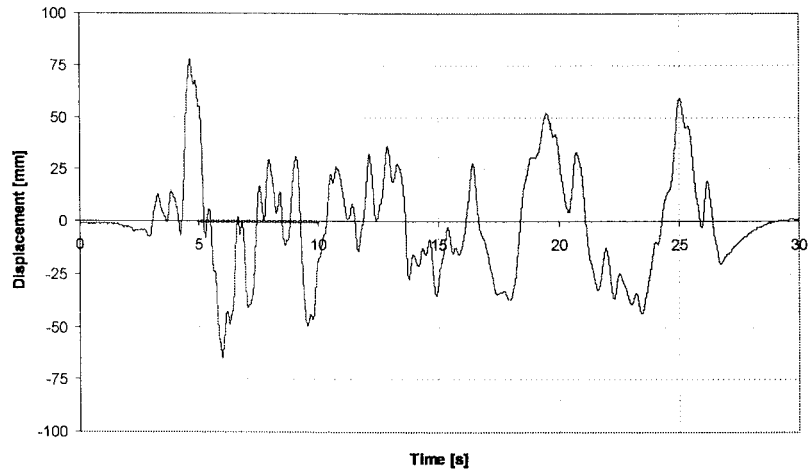


**Figure 151:** Top vertical acceleration (A9).

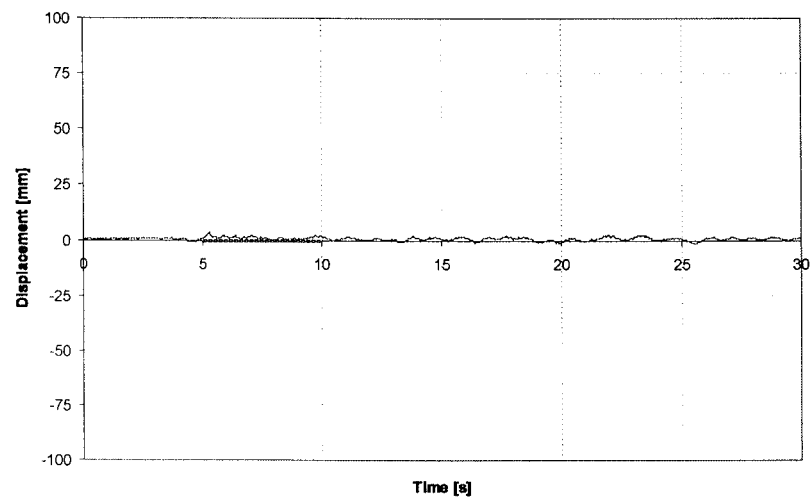


**Figure 152:** Mass displacement (D1).





**Figure 153:** EW displacement in shaking table (D2).

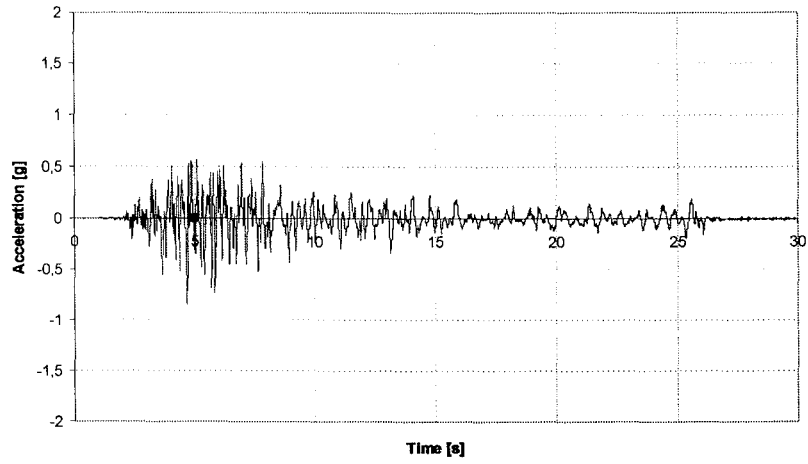


**Figure 154:** NS Displacement in shaking table (D3).

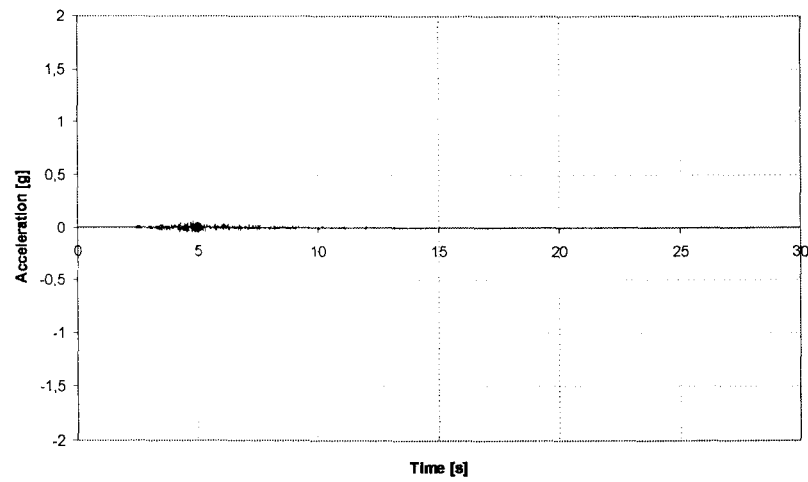


**Test 12 – PGA=0.8g with 0.1 seconds discharge**

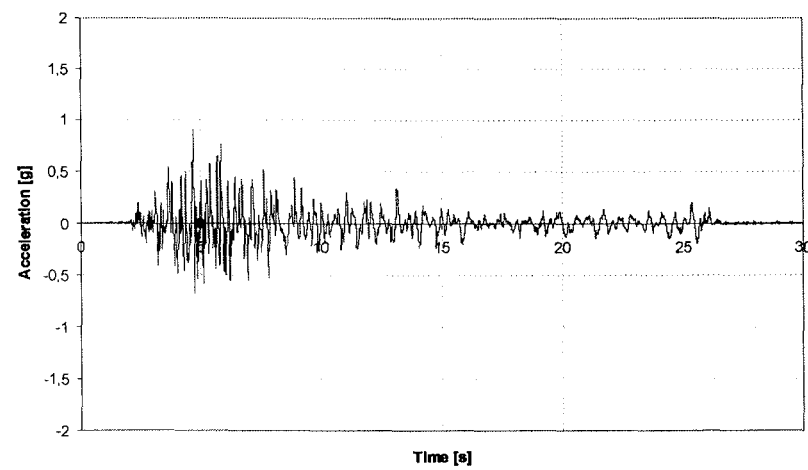




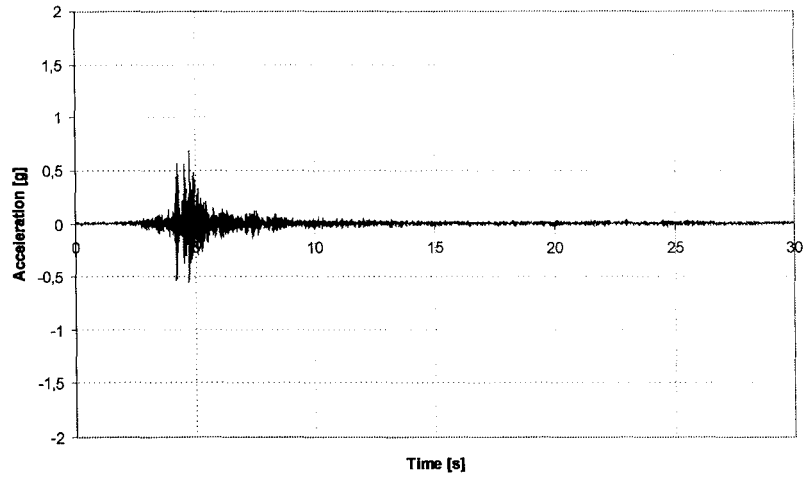
**Figure 155:** EW acceleration in shaking table.



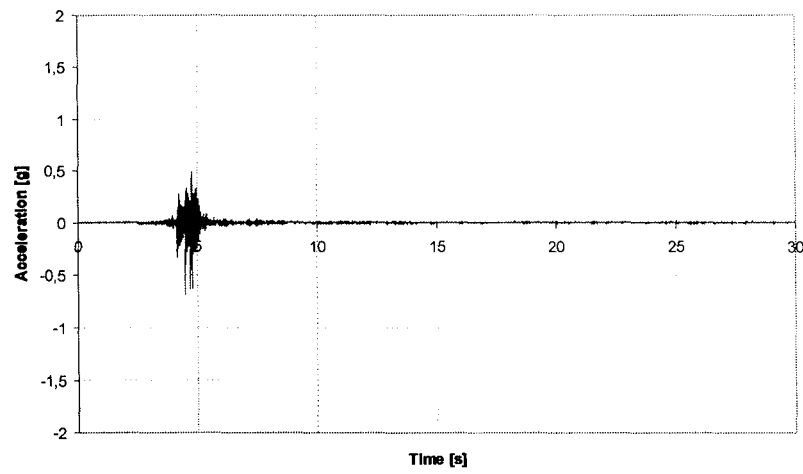
**Figure 156:** NS acceleration in shaking table.



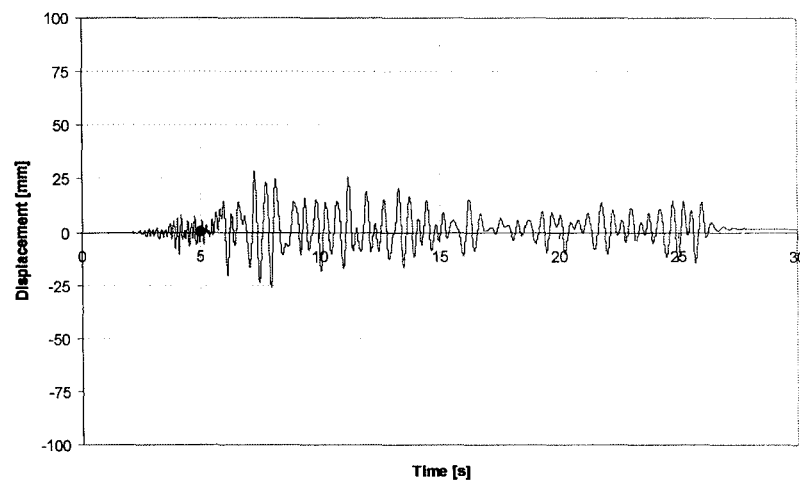
**Figure 157:** Bottom EW acceleration (A1).



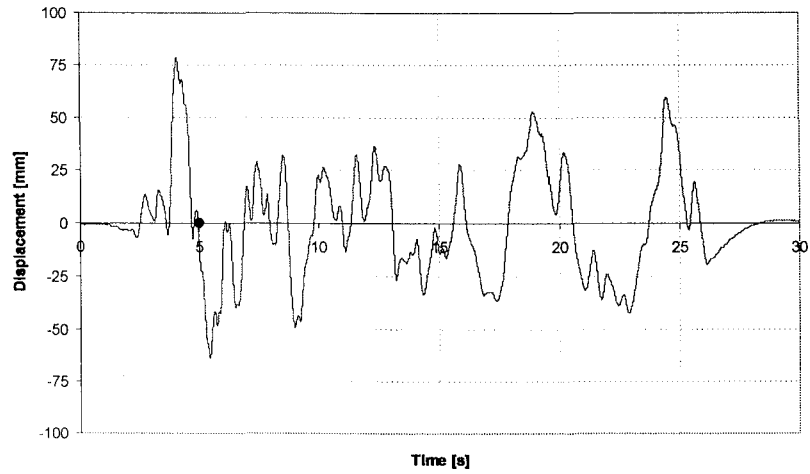
**Figure 164:** Top NS acceleration (A8).



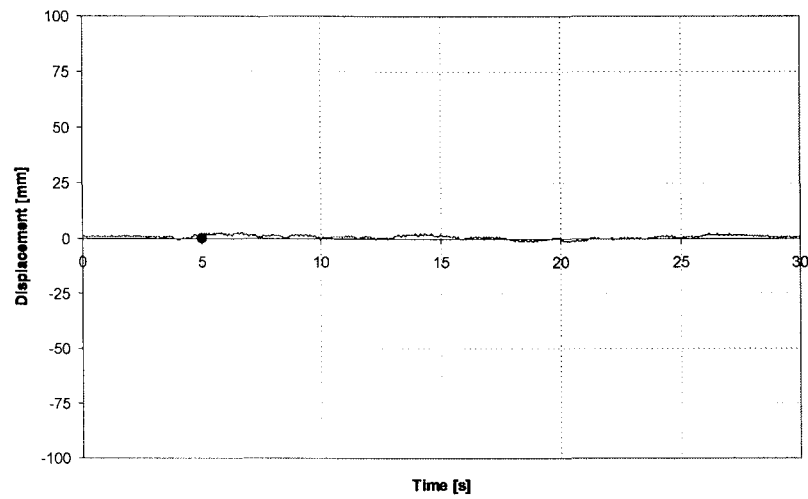
**Figure 165:** Top vertical acceleration (A9).



**Figure 166:** Mass displacement (D1).



**Figure 167:** EW displacement in shaking table (D2).



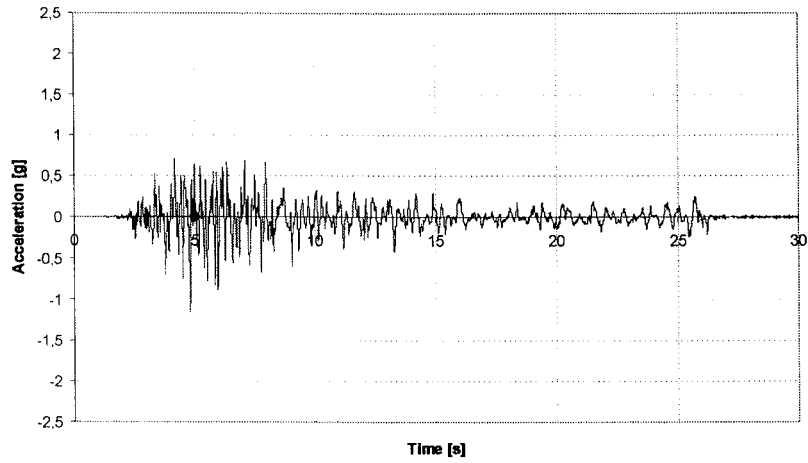
**Figure 168:** NS Displacement in shaking table (D3).



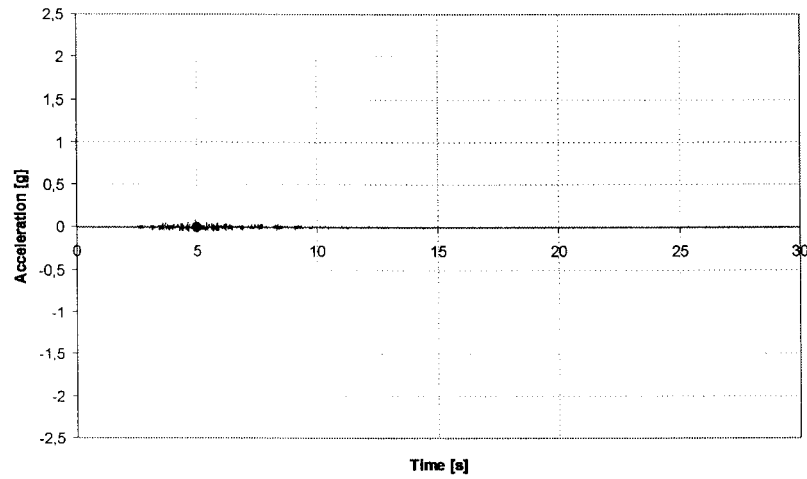


**Test 13 – PGA=1.0g with a 0.1 seconds discharge**

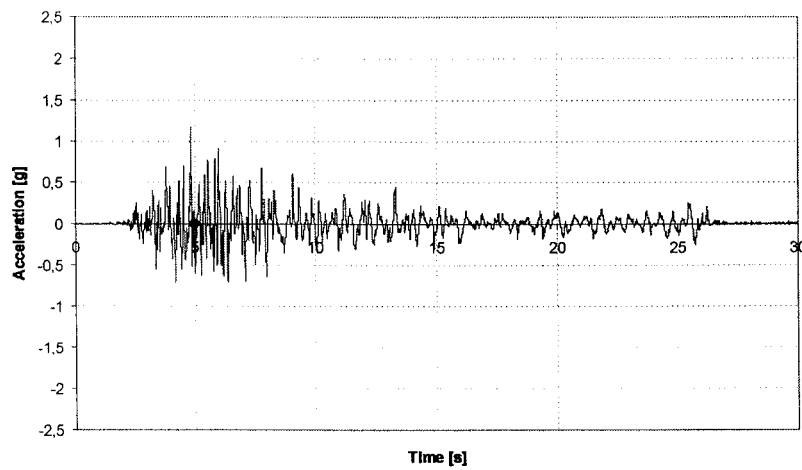




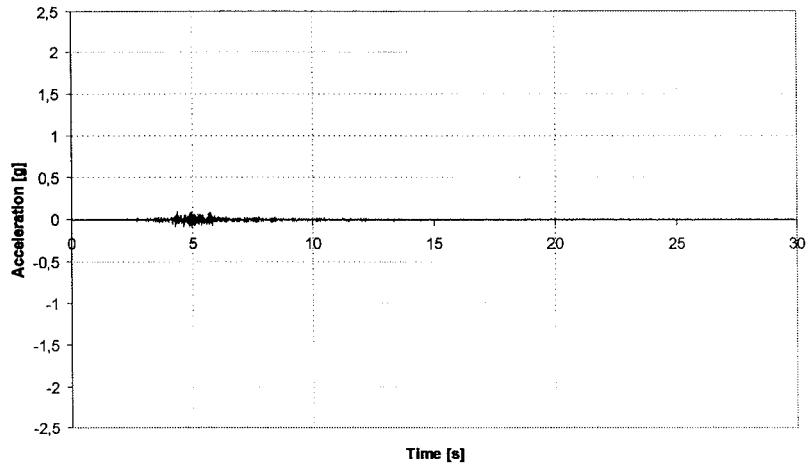
**Figure 169:** EW acceleration in shaking table.



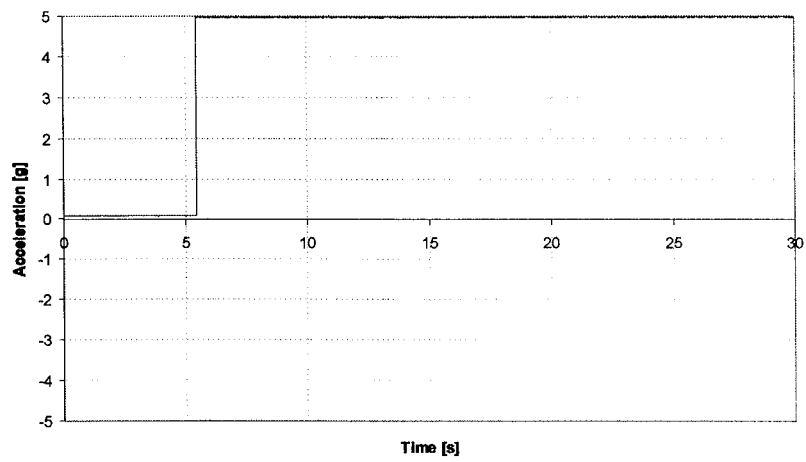
**Figure 170:** NS acceleration in shaking table.



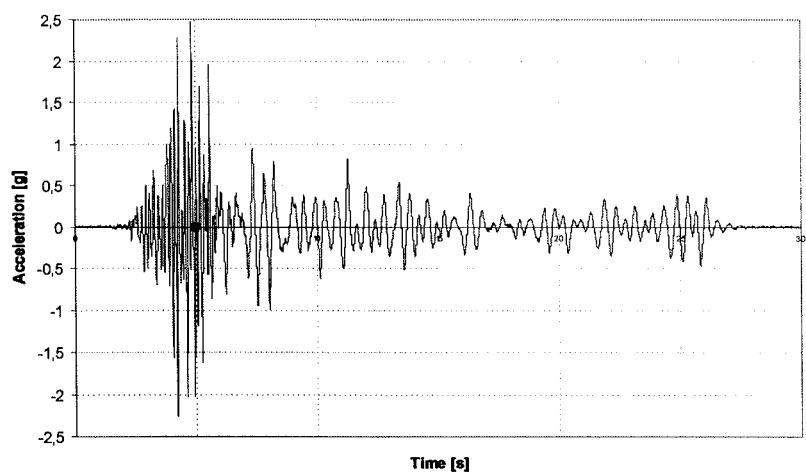
**Figure 171:** Bottom EW acceleration (A1).



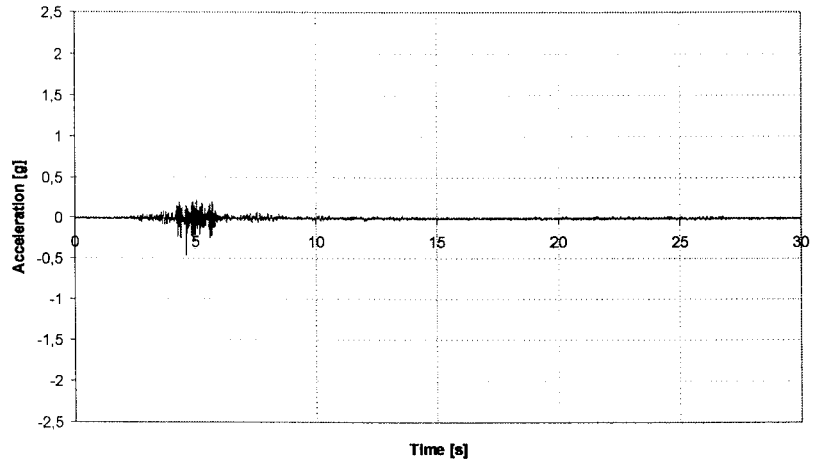
**Figure 172:** Bottom NS Acceleration (A2).



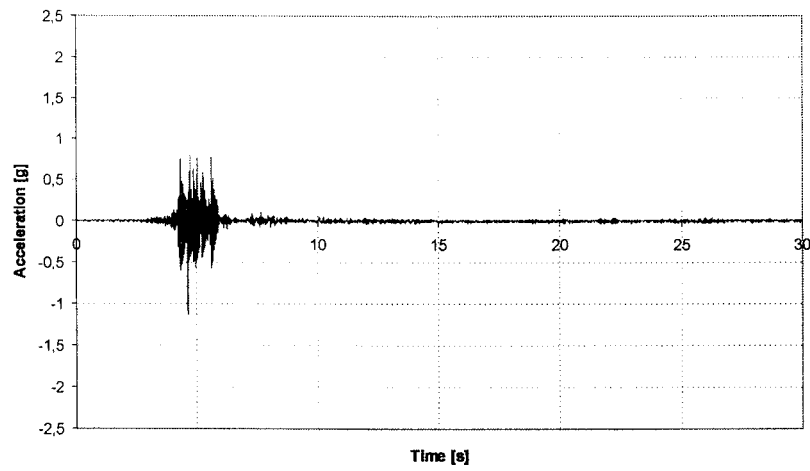
**Figure 173:** Air Bag Pressure Trigger.



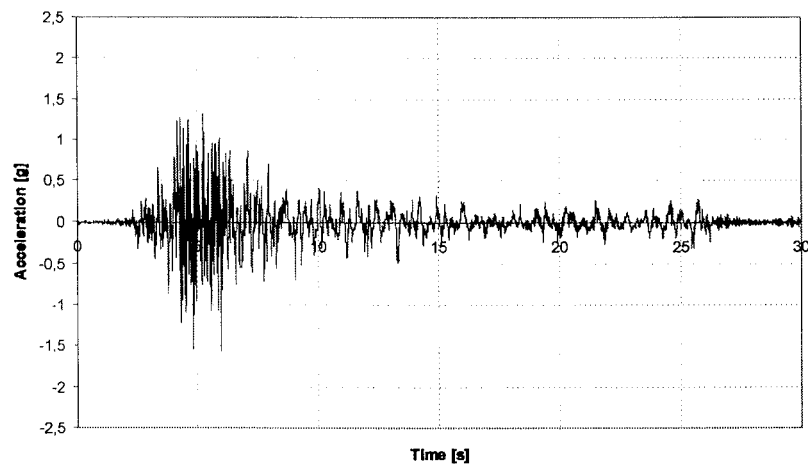
**Figure 174:** Mass EW acceleration (A4).



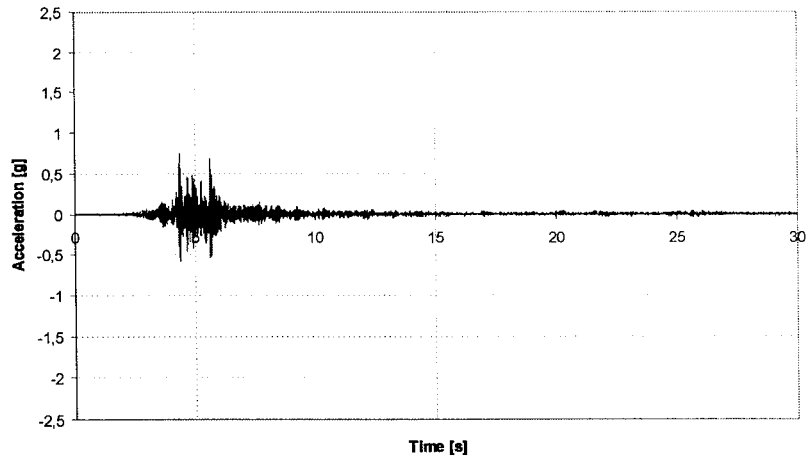
**Figure 175:** Mass NS acceleration (A5).



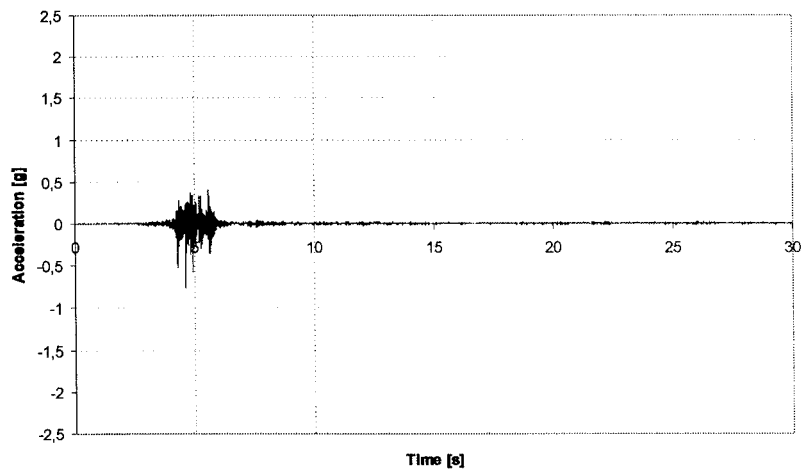
**Figure 176:** Mass vertical acceleration (A6).



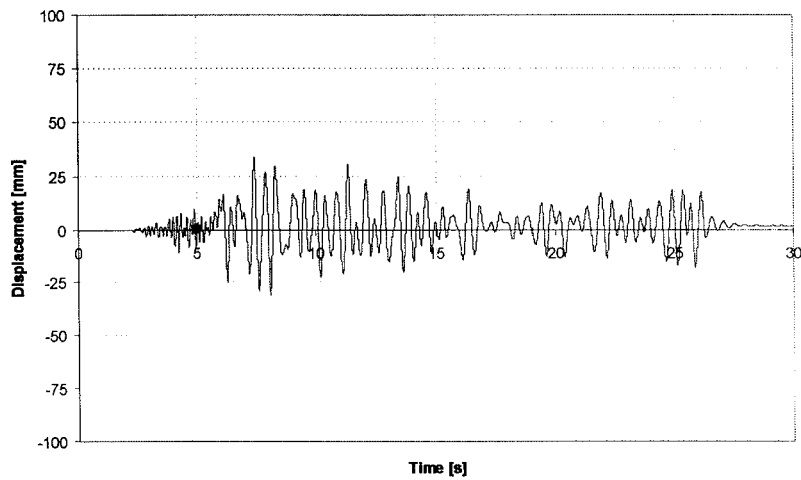
**Figure 177:** Top EW acceleration (A7).



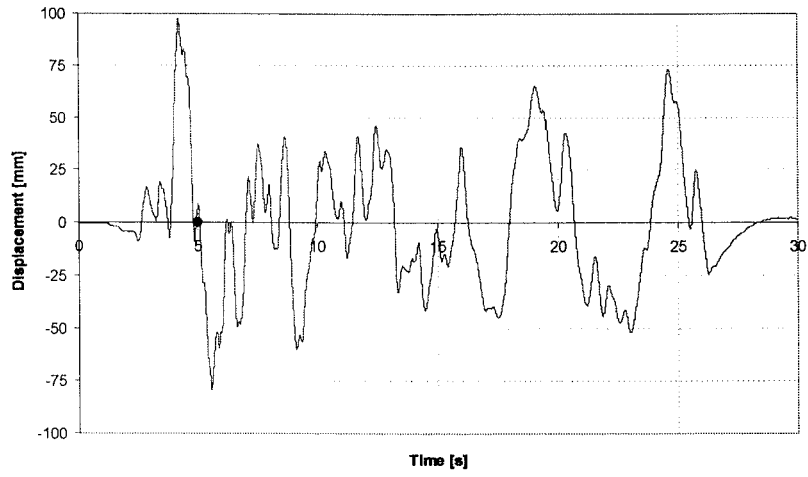
**Figure 178:** Top NS acceleration (A8).



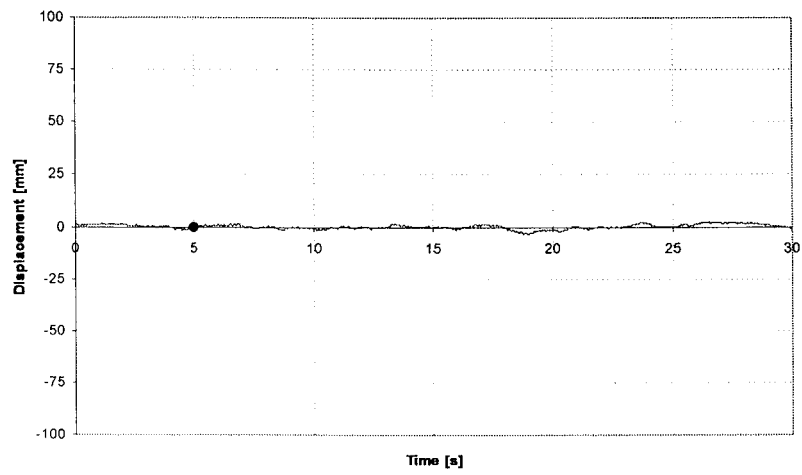
**Figure 179:** Top vertical acceleration (A9).



**Figure 180:** Mass displacement (D1).



**Figure 181:** EW displacement in shaking table (D2).



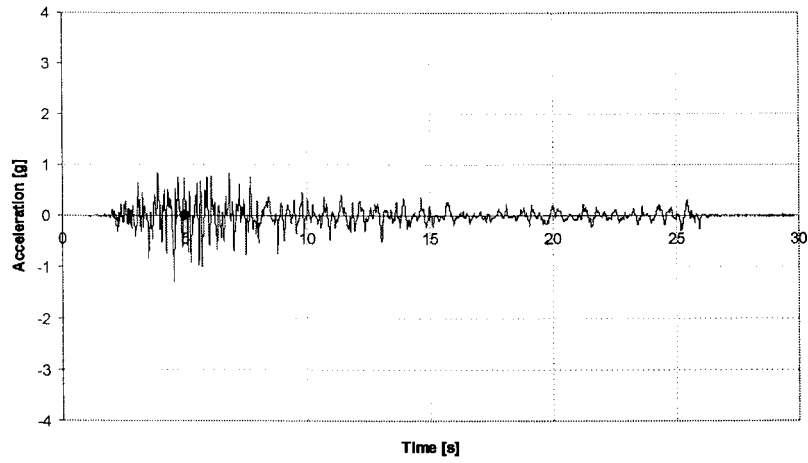
**Figure 182:** NS Displacement in shaking table (D3).



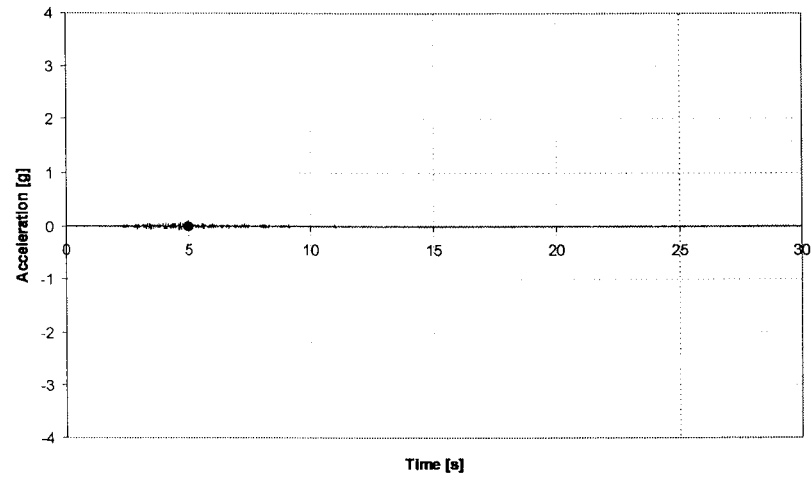


**Test 14 – PGA=1.2g with a 0.1 discharge**

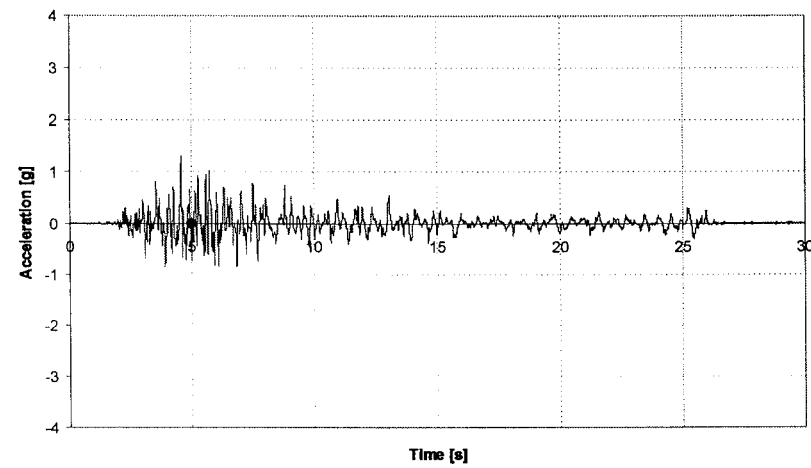




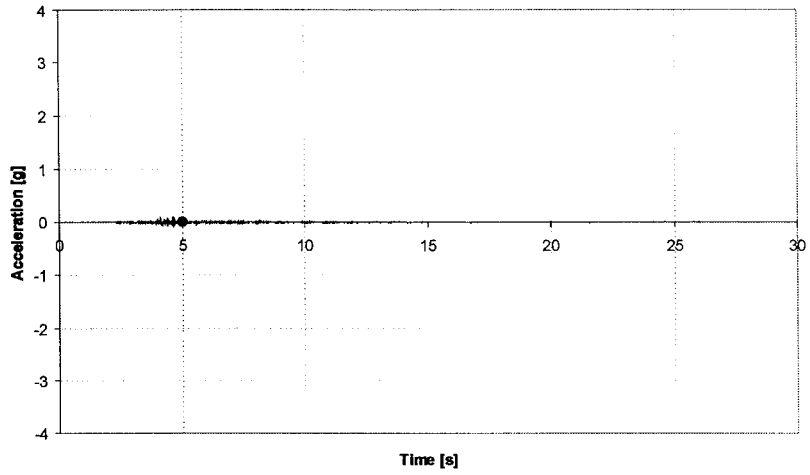
**Figure 183:** EW acceleration in shaking table.



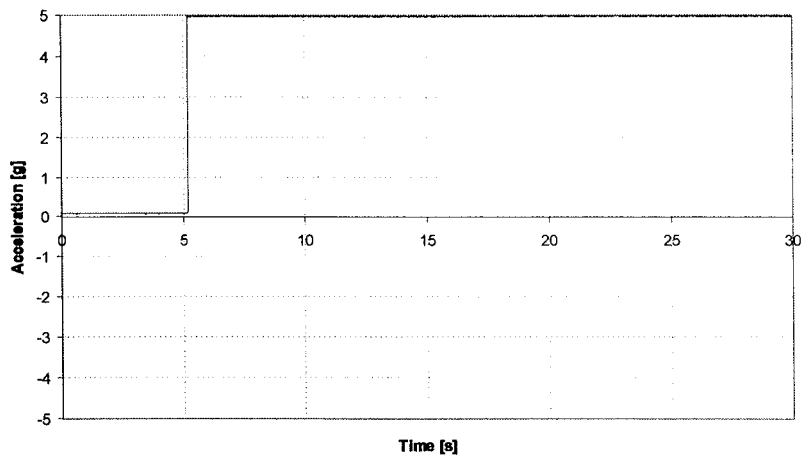
**Figure 184:** NS acceleration in shaking table.



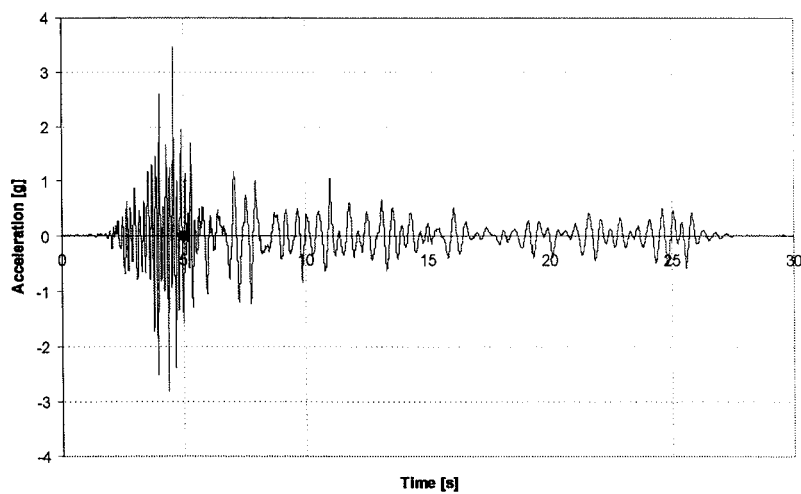
**Figure 185:** Bottom EW acceleration (A1).



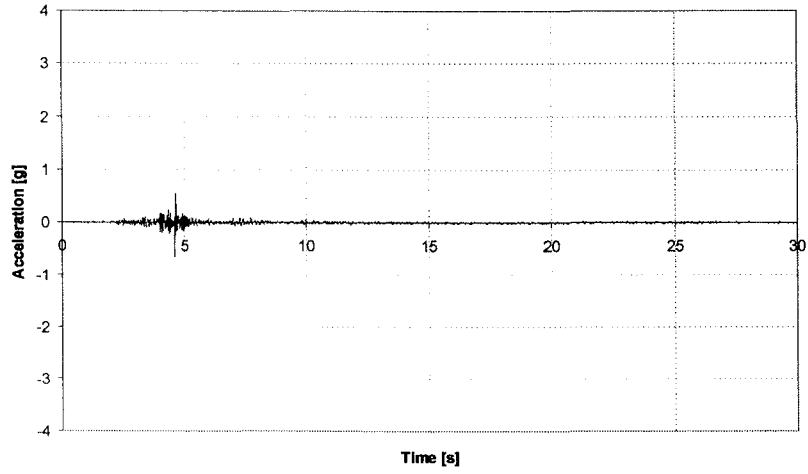
**Figure 186:** Bottom NS Acceleration (A2).



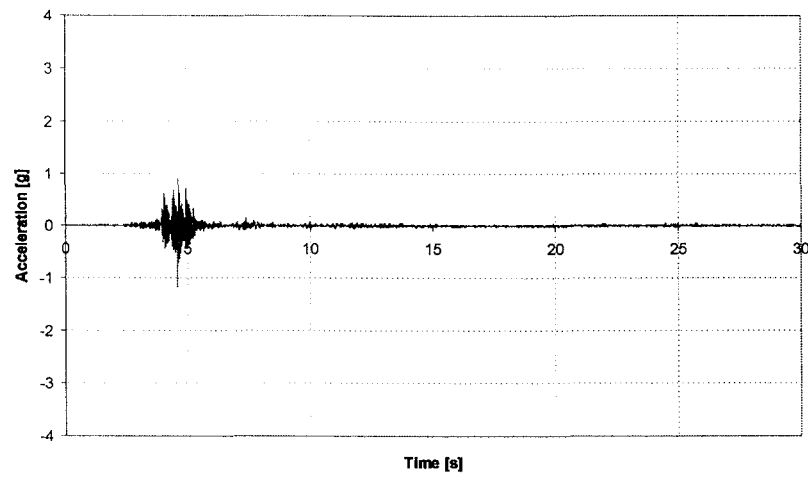
**Figure 187:** Air Bag Pressure Trigger.



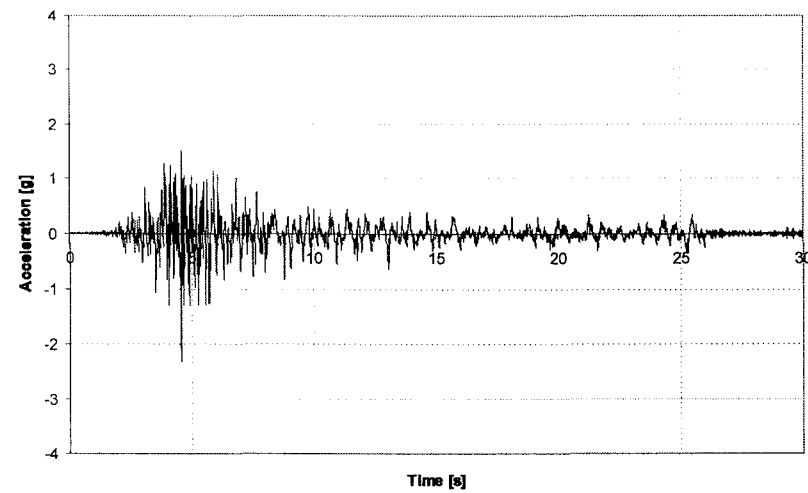
**Figure 188:** Mass EW acceleration (A4).



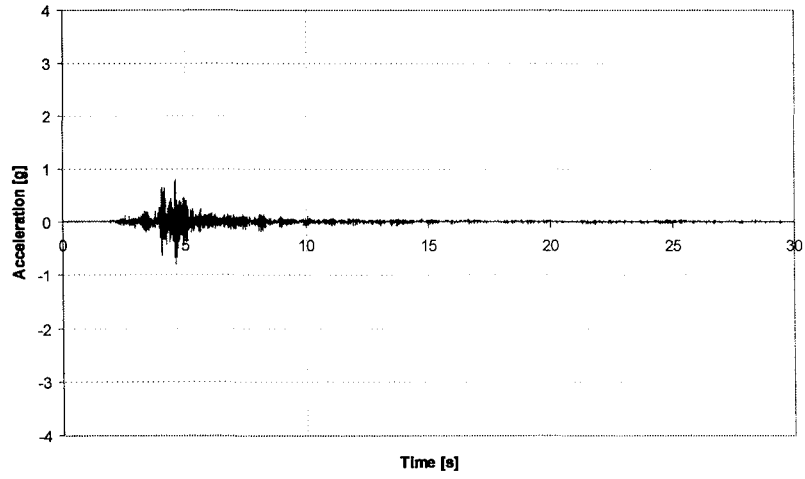
**Figure 189:** Mass NS acceleration (A5).



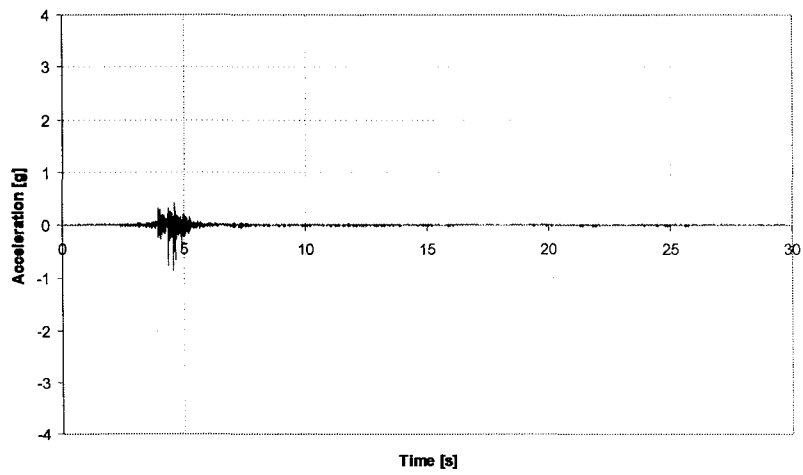
**Figure 190:** Mass vertical acceleration (A6).



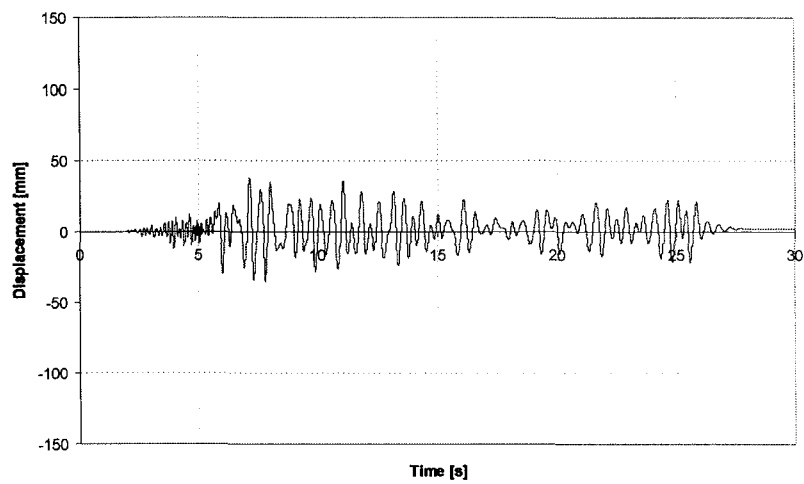
**Figure 191:** Top EW acceleration (A7).



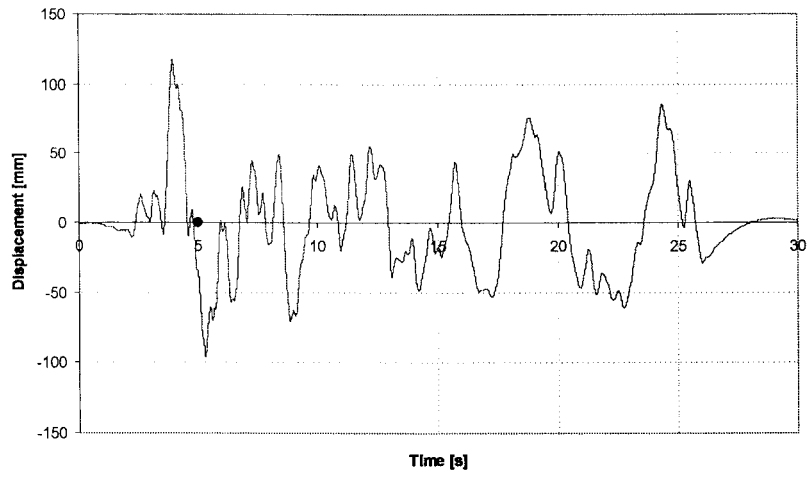
**Figure 192:** Top NS acceleration (A8).



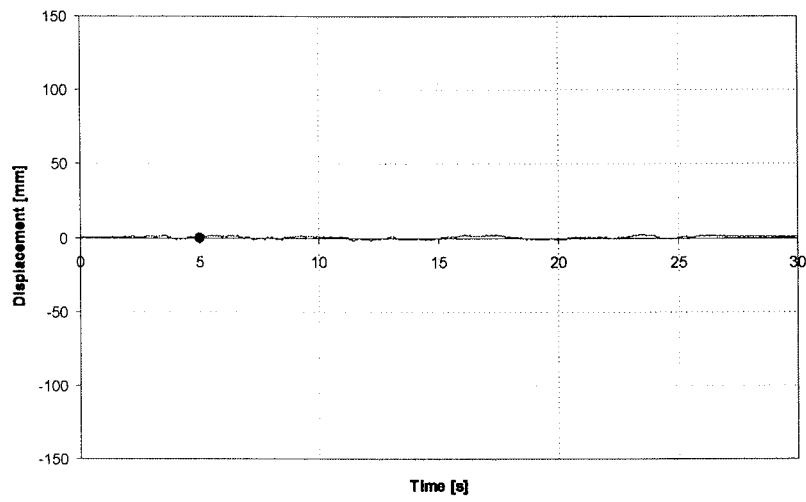
**Figure 193:** Top vertical acceleration (A9).



**Figure 194:** Mass displacement (D1).



**Figure 195:** EW displacement in shaking table (D2).



**Figure 196:** NS Displacement in shaking table (D3).





## **ANNEX IV – Preliminary results analysis**



## FIGURES INDEX

### PGA=0.1g (Tests 1, 2 and 3)

<b>Figure 1:</b> Relation between acceleration time series (Shaking table) during Tests 1 to 3.....	3
<b>Figure 2:</b> Relation between acceleration time series (Shaking table) during Tests 1 to 3 (from 5 to 10 seconds).....	3
<b>Figure 3:</b> Relation between displacement time series (Shaking table) during Tests 1 to 3.....	3
<b>Figure 4:</b> Acceleration response spectra (Shaking Table) for Tests 1 and 2.....	4
<b>Figure 5:</b> Acceleration response spectra (Shaking Table) for Tests 1 and 3.....	4
<b>Figure 6:</b> Acceleration-displacement response spectra (Shaking Table) for Tests 1 to 3.....	4
<b>Figure 7:</b> Amplitude of the transfer function between the shaking table (Table EW) and the mass of the model (A4EW) – Test 1.....	5
<b>Figure 8:</b> Amplitude of the transfer function between the shaking table (Table EW) and the mass of the model (A4EW) – Test 2.....	5
<b>Figure 9:</b> Amplitude of the transfer function between the shaking table (Table EW) and the mass of the model (A4EW) – Test 3.....	5
<b>Figure 10:</b> Force displacement relationship for Test 1.....	6
<b>Figure 11:</b> Force displacement relationship for Test 2.....	6
<b>Figure 12:</b> Force displacement relationship for Test 3.....	6

### PGA=0.4g (Tests 4, 5 and 6)

<b>Figure 13:</b> Relation between acceleration time series (Shaking table) during Tests 4 to 6.....	9
<b>Figure 14:</b> Relation between acceleration time series (Shaking table) during Tests 4 to 6 (from 5 to 10 seconds).....	9
<b>Figure 15:</b> Relation between displacement time series (Shaking table) during Tests 4 to 6.....	9
<b>Figure 16:</b> Acceleration response spectra (Shaking Table) for Tests 4 and 5.....	10
<b>Figure 17:</b> Acceleration response spectra (Shaking Table) for Tests 4 and 6.....	10
<b>Figure 18:</b> Acceleration-displacement response spectra (Shaking Table) for Tests 4 to 6.....	10
<b>Figure 19:</b> Amplitude of the transfer function between the shaking table (Table EW) and the mass of the model (A4EW) – Test 4.....	11
<b>Figure 20:</b> Amplitude of the transfer function between the shaking table (Table EW) and the mass of the model (A4EW) – Test 5.....	11
<b>Figure 21:</b> Amplitude of the transfer function between the shaking table (Table EW) and the mass of the model (A4EW) – Test 6.....	11
<b>Figure 22:</b> Force displacement relationship for Test 4.....	12
<b>Figure 23:</b> Force displacement relationship for Test 5.....	12
<b>Figure 24:</b> Force displacement relationship for Test 6.....	12

### PGA=0.6g (Tests 7, 8 and 9)

<b>Figure 25:</b> Relation between acceleration time series (Shaking table) during Tests 7 to 9.....	15
<b>Figure 26:</b> Relation between acceleration time series (Shaking table) during Tests 7 to 9 (from 5 to 10 seconds).....	15
<b>Figure 27:</b> Relation between displacement time series (Shaking table) during Tests 7 to 9.....	15
<b>Figure 28:</b> Acceleration response spectra (Shaking Table) for Tests 7 and 8.....	16
<b>Figure 29:</b> Acceleration response spectra (Shaking Table) for Tests 7 and 9.....	16
<b>Figure 30:</b> Acceleration-displacement response spectra (Shaking Table) for Tests 7 to 9.....	16

<b>Figure 31:</b> Amplitude of the transfer function between the shaking table (Table EW) and the mass of the model (A4EW) – Test 7.....	17
<b>Figure 32:</b> Amplitude of the transfer function between the shaking table (Table EW) and the mass of the model (A4EW) – Test 8.....	17
<b>Figure 33:</b> Amplitude of the transfer function between the shaking table (Table EW) and the mass of the model (A4EW) – Test 9.....	17
<b>Figure 34:</b> Force displacement relationship for Test 7.....	18
<b>Figure 35:</b> Force displacement relationship for Test 8.....	18
<b>Figure 36:</b> Force displacement relationship for Test 9.....	18

**PGA=0.8g (Tests 10, 11 and 12)**

<b>Figure 37:</b> Relation between acceleration time series (Shaking table) during Tests 10 to 12. ....	21
<b>Figure 38:</b> Relation between acceleration time series (Shaking table) during Tests 10 to 12 (from 5 to 10 seconds). ....	21
<b>Figure 39:</b> Relation between displacement time series (Shaking table) during Tests 10 to 12. ....	21
<b>Figure 40:</b> Acceleration response spectra (Shaking Table) for Tests 10 and 11.....	22
<b>Figure 41:</b> Acceleration response spectra (Shaking Table) for Tests 10 and 12.....	22
<b>Figure 42:</b> Acceleration-displacement response spectra (Shaking Table) for Tests 10 to 12.....	22
<b>Figure 43:</b> Amplitude of the transfer function between the shaking table (Table EW) and the mass of the model (A4EW) – Test 10.....	23
<b>Figure 44:</b> Amplitude of the transfer function between the shaking table (Table EW) and the mass of the model (A4EW) – Test 11.....	23
<b>Figure 45:</b> Amplitude of the transfer function between the shaking table (Table EW) and the mass of the model (A4EW) – Test 12.....	23
<b>Figure 46:</b> Force displacement relationship for Test 10.....	24
<b>Figure 47:</b> Force displacement relationship for Test 11.....	24
<b>Figure 48:</b> Force displacement relationship for Test 12.....	24

**PGA=1.0g (Test 13)**

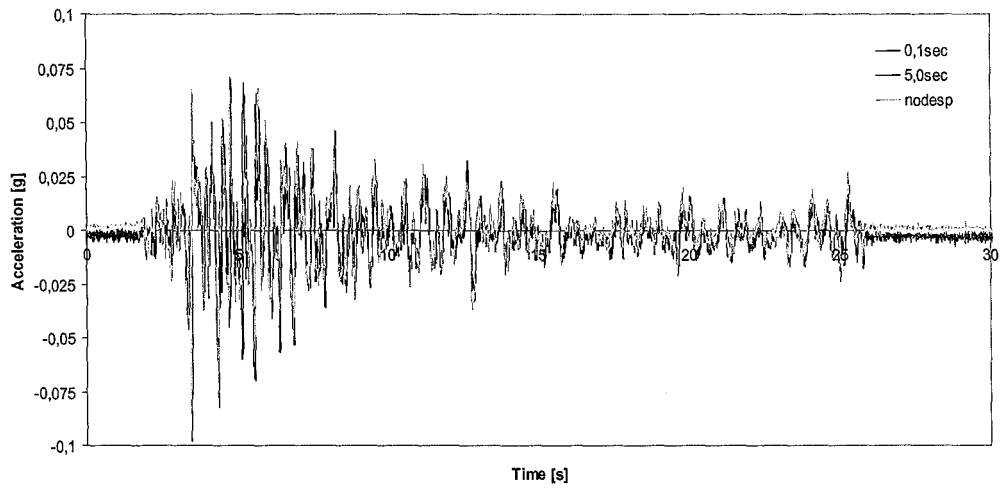
<b>Figure 49:</b> Acceleration time series (Shaking table) during Tests 13 (from 5 to 10 seconds).....	27
<b>Figure 50:</b> Displacement time series (Shaking table) during Tests 13.....	27
<b>Figure 51:</b> Acceleration response spectra (Shaking Table) for Test 13. ....	27
<b>Figure 52:</b> Acceleration-displacement response spectra (Shaking Table) for Test 13. ....	28
<b>Figure 53:</b> Amplitude of the transfer function between the shaking table (Table EW) and the mass of the model (A4EW) – Test 13.....	28
<b>Figure 54:</b> Force displacement relationship for Test 13.....	28

**PGA=1.2g (Test 14)**

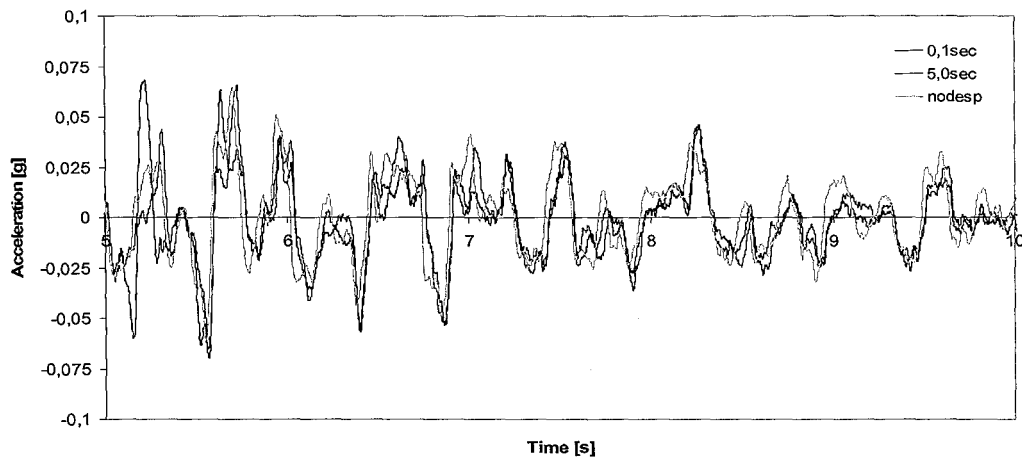
<b>Figure 55:</b> Acceleration time series (Shaking table) during Test 14 (from 5 to 10 seconds). ....	31
<b>Figure 56:</b> Displacement time series (Shaking table) during Test 14.....	31
<b>Figure 57:</b> Acceleration response spectra (Shaking Table) for Test 14. ....	31
<b>Figure 58:</b> Acceleration-displacement response spectra (Shaking Table) for Test 14. ....	32
<b>Figure 59:</b> Amplitude of the transfer function between the shaking table (Table EW) and the mass of the model (A4EW) – Test 14.....	32
<b>Figure 60:</b> Force displacement relationship for Test 14.....	32

**PGA=0.1g (Tests 1, 2 and 3)**

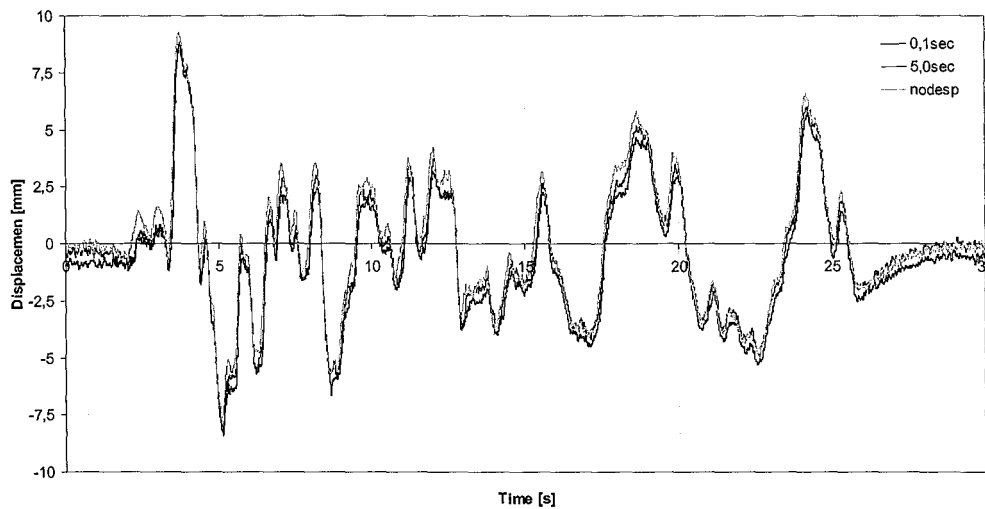




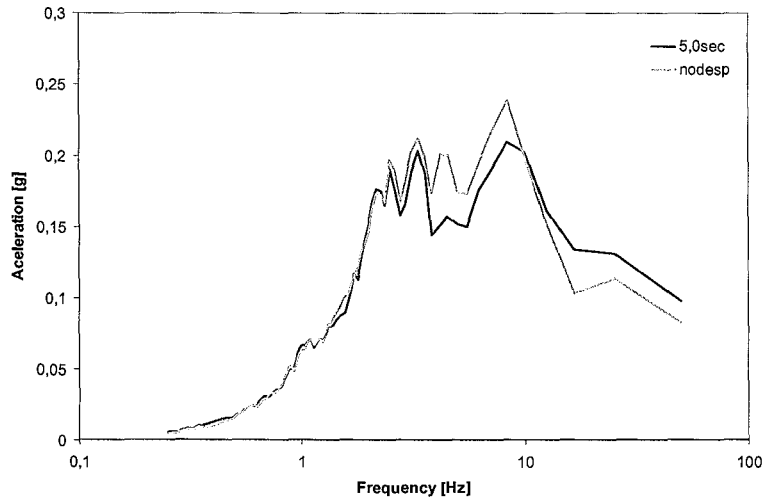
**Figure 1:** Relation between acceleration time series (Shaking table) during Tests 1 to 3.



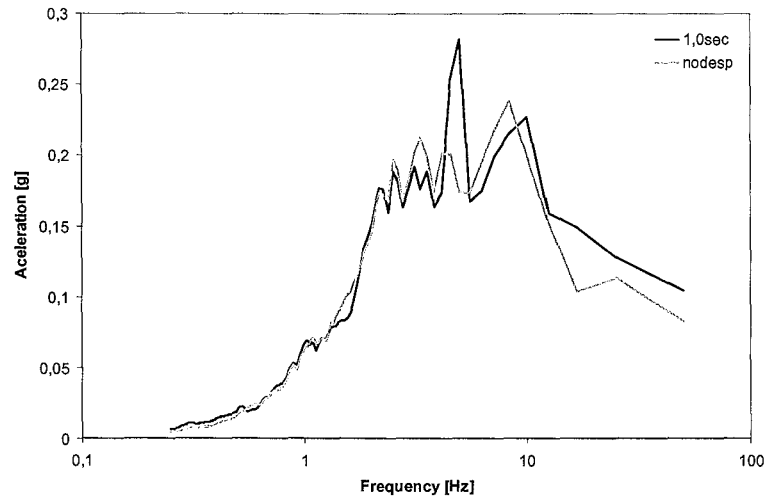
**Figure 2:** Relation between acceleration time series (Shaking table) during Tests 1 to 3 (from 5 to 10 seconds).



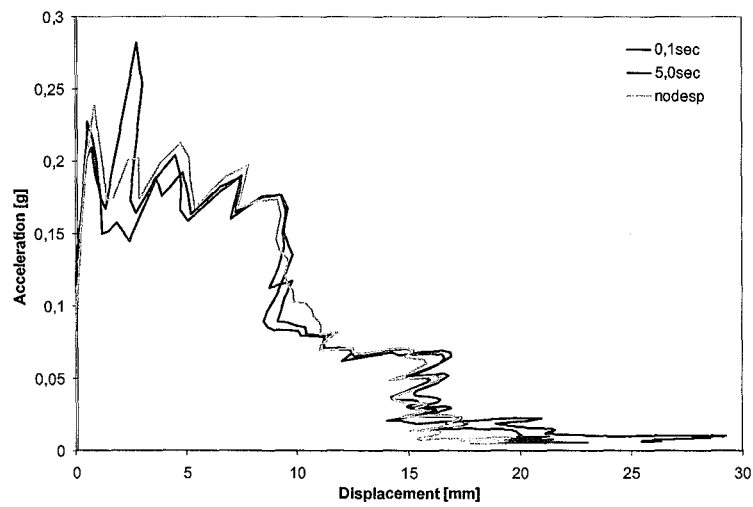
**Figure 3:** Relation between displacement time series (Shaking table) during Tests 1 to 3.



**Figure 4:** Acceleration response spectra (Shaking Table) for Tests 1 and 2.

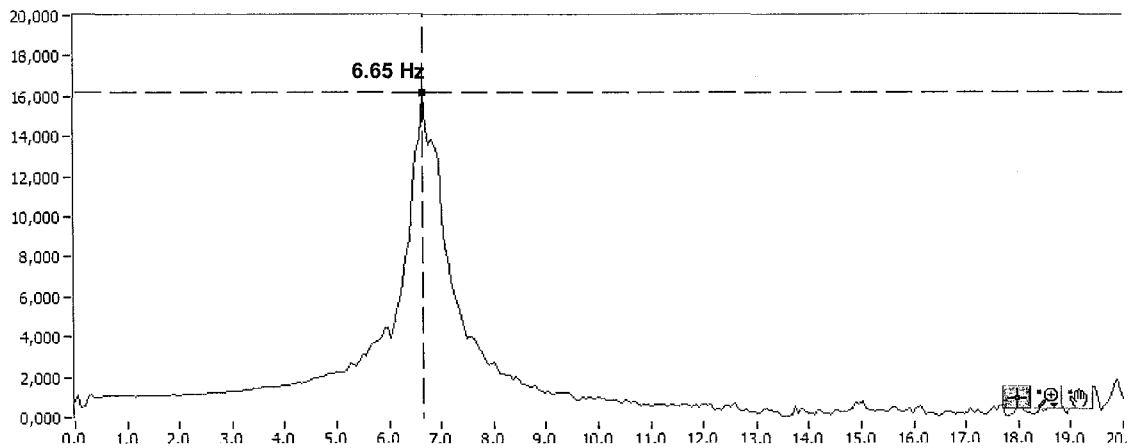


**Figure 5:** Acceleration response spectra (Shaking Table) for Tests 1 and 3.

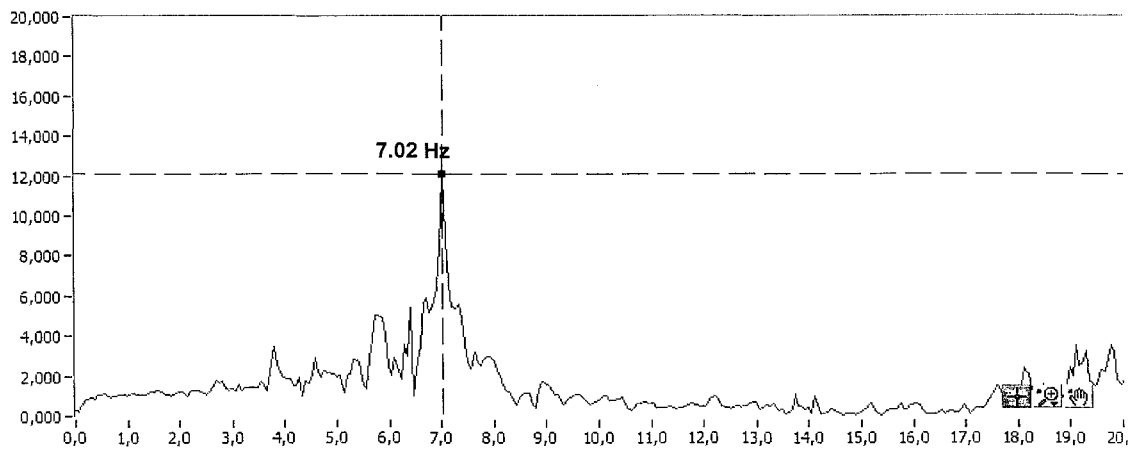


**Figure 6:** Acceleration-displacement response spectra (Shaking Table) for Tests 1 to 3.

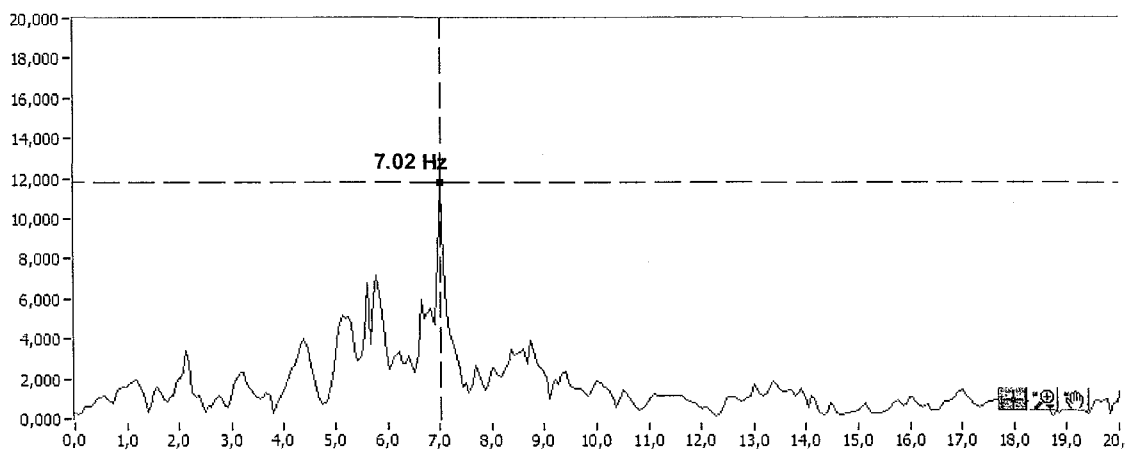




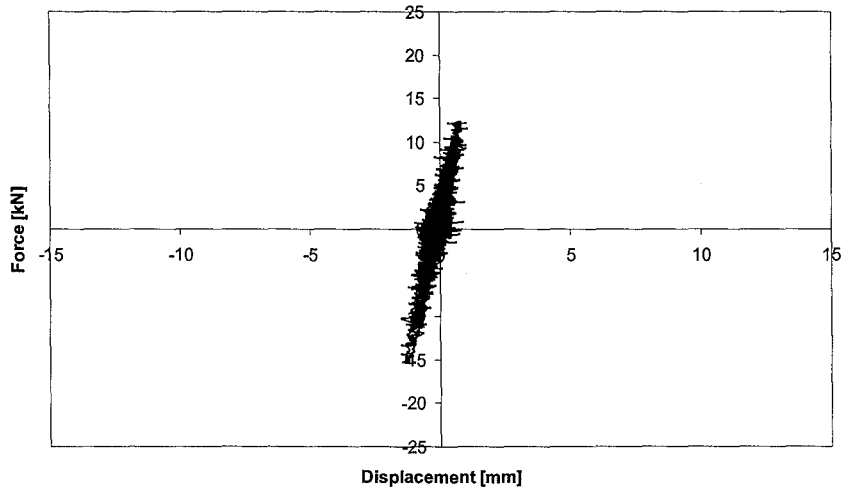
**Figure 7:** Amplitude of the transfer function between the shaking table (Table EW) and the mass of the model (A4EW) – Test 1.



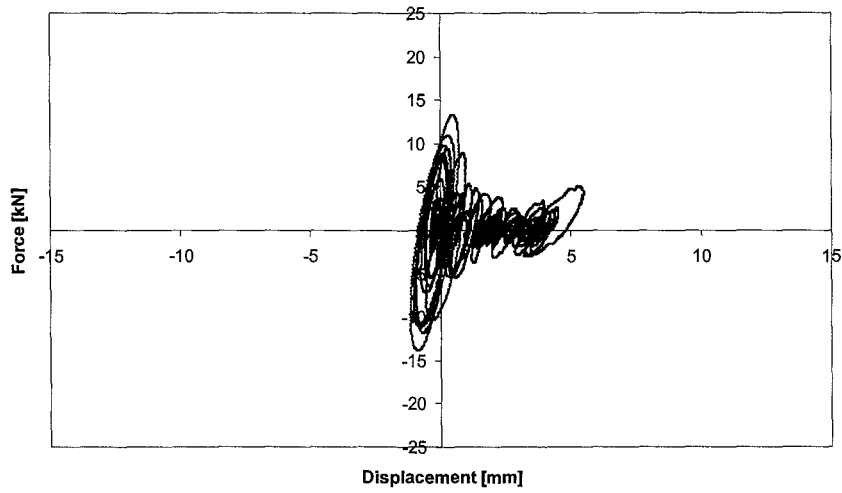
**Figure 8:** Amplitude of the transfer function between the shaking table (Table EW) and the mass of the model (A4EW) – Test 2.



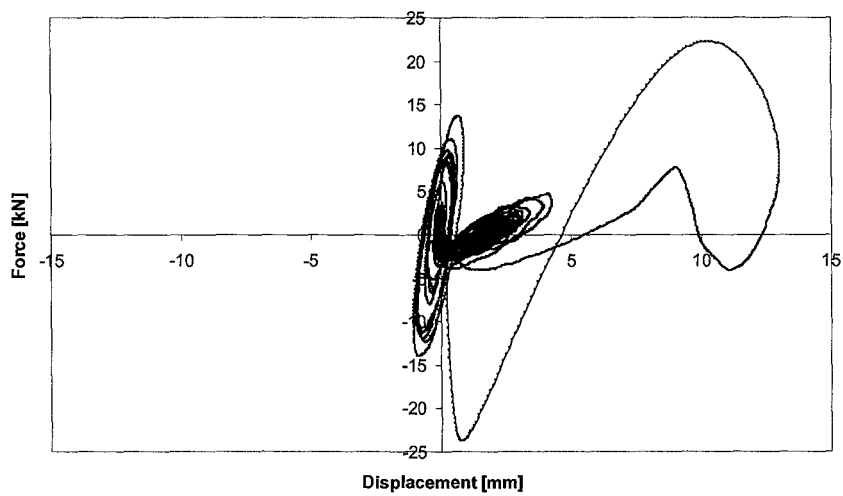
**Figure 9:** Amplitude of the transfer function between the shaking table (Table EW) and the mass of the model (A4EW) – Test 3.



**Figure 10:** Force displacement relationship for Test 1.



**Figure 11:** Force displacement relationship for Test 2.



**Figure 12:** Force displacement relationship for Test 3.

**PGA=0.4g (Tests 4, 5 and 6)**



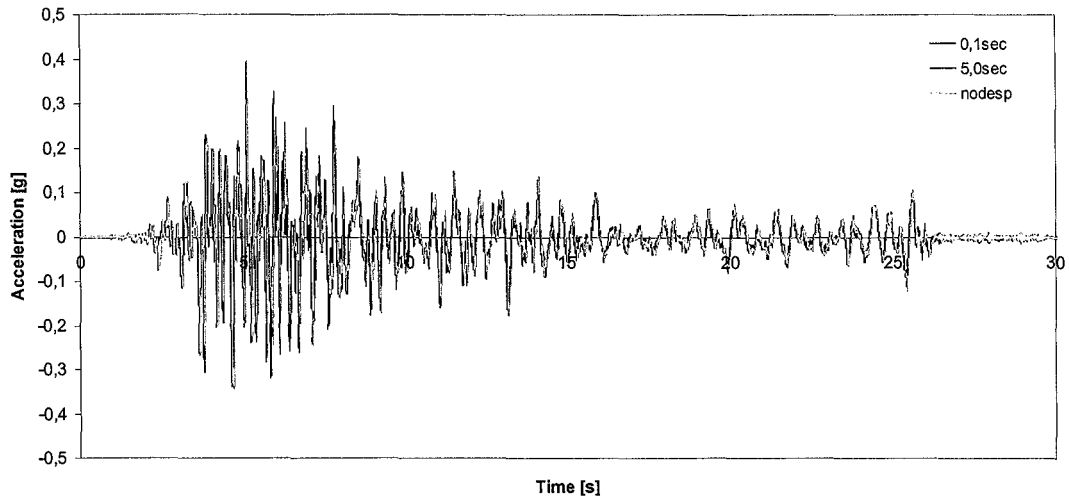


Figure 13: Relation between acceleration time series (Shaking table) during Tests 4 to 6.

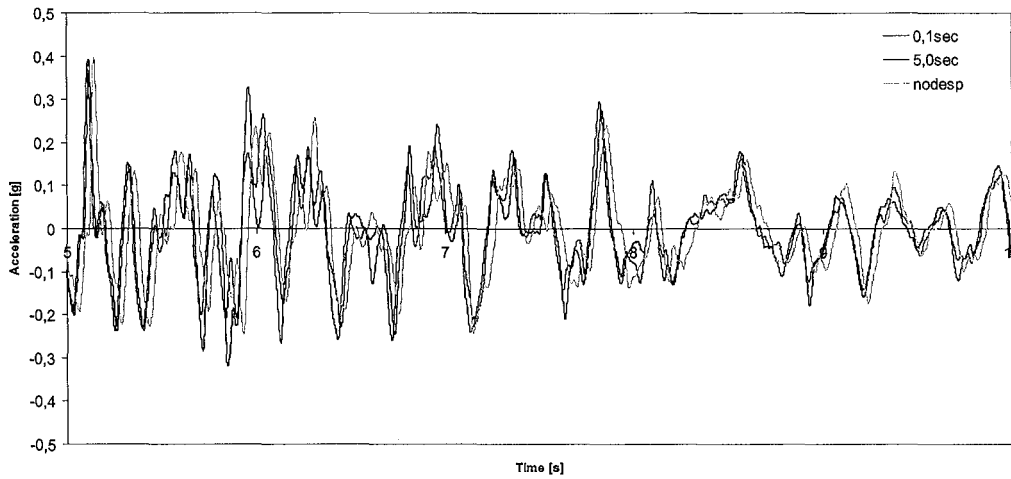


Figure 14: Relation between acceleration time series (Shaking table) during Tests 4 to 6 (from 5 to 10 seconds).

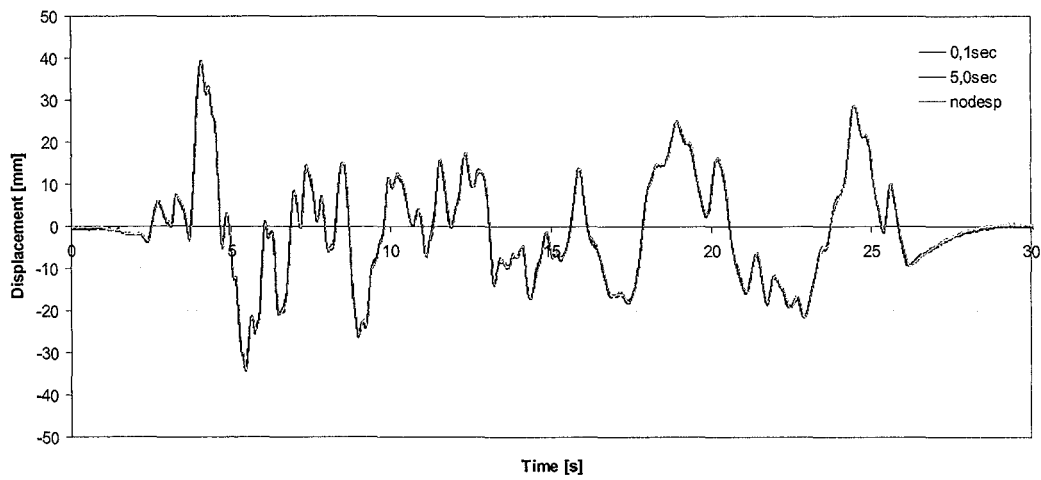
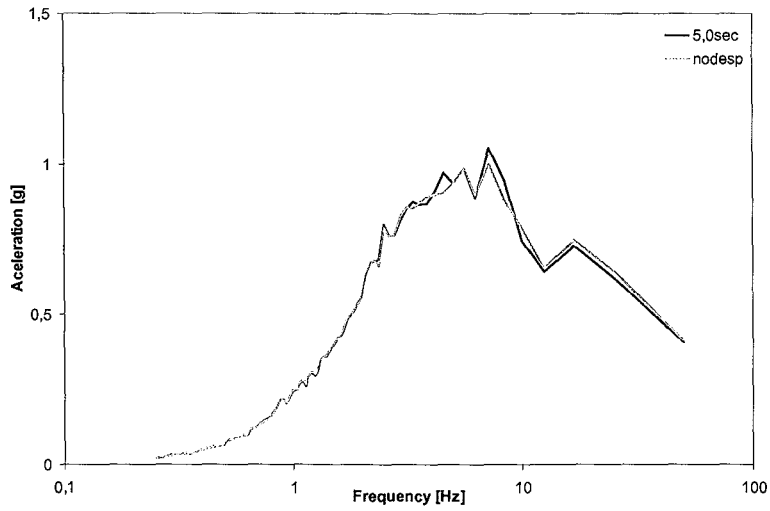
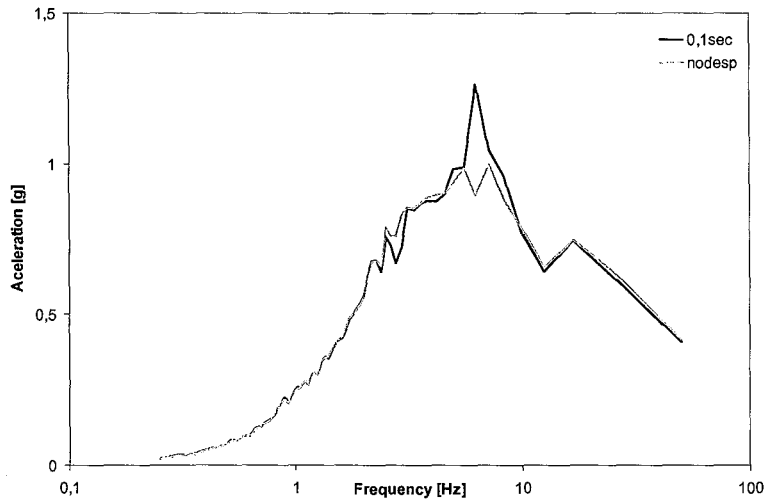


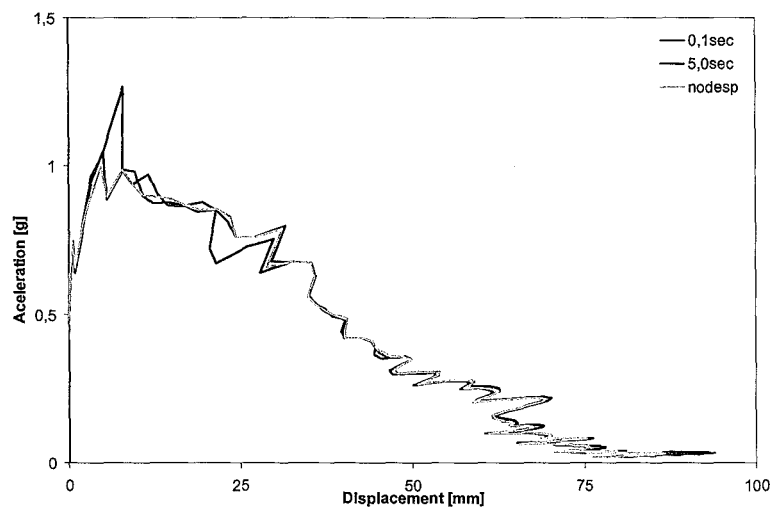
Figure 15: Relation between displacement time series (Shaking table) during Tests 4 to 6.



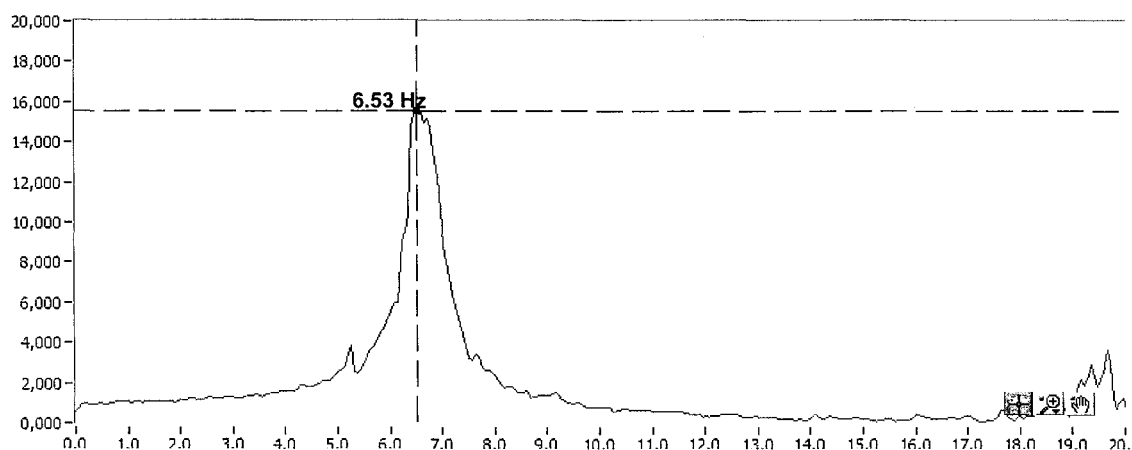
**Figure 16:** Acceleration response spectra (Shaking Table) for Tests 4 and 5.



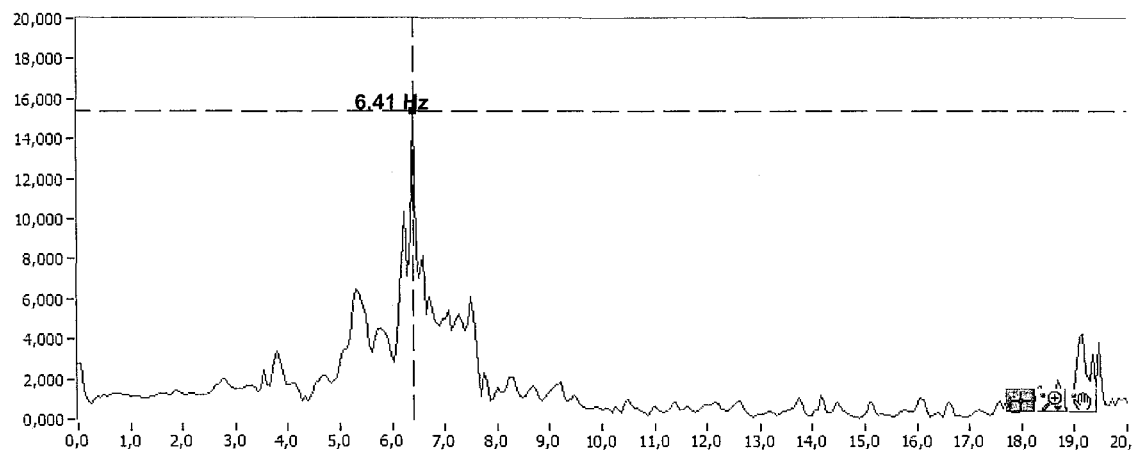
**Figure 17:** Acceleration response spectra (Shaking Table) for Tests 4 and 6.



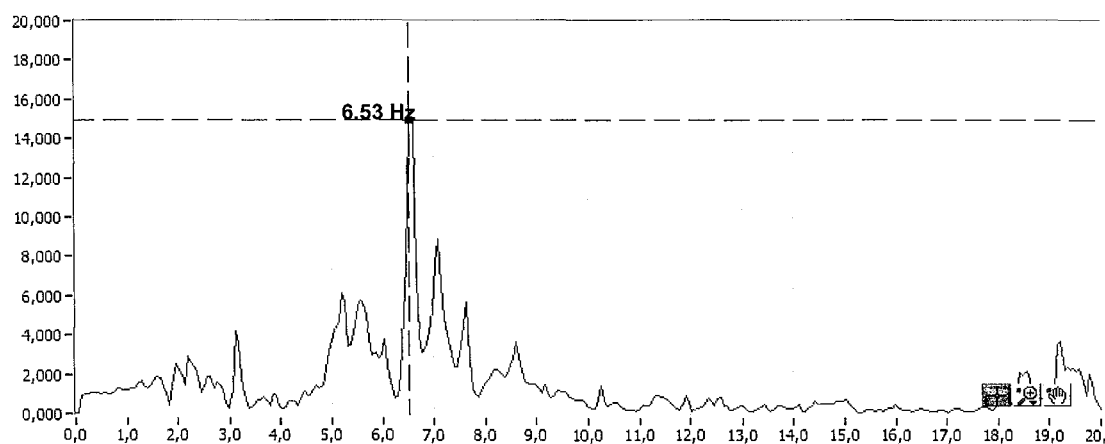
**Figure 18:** Acceleration-displacement response spectra (Shaking Table) for Tests 4 to 6.



**Figure 19:** Amplitude of the transfer function between the shaking table (Table EW) and the mass of the model (A4EW) – Test 4.



**Figure 20:** Amplitude of the transfer function between the shaking table (Table EW) and the mass of the model (A4EW) – Test 5.



**Figure 21:** Amplitude of the transfer function between the shaking table (Table EW) and the mass of the model (A4EW) – Test 6.

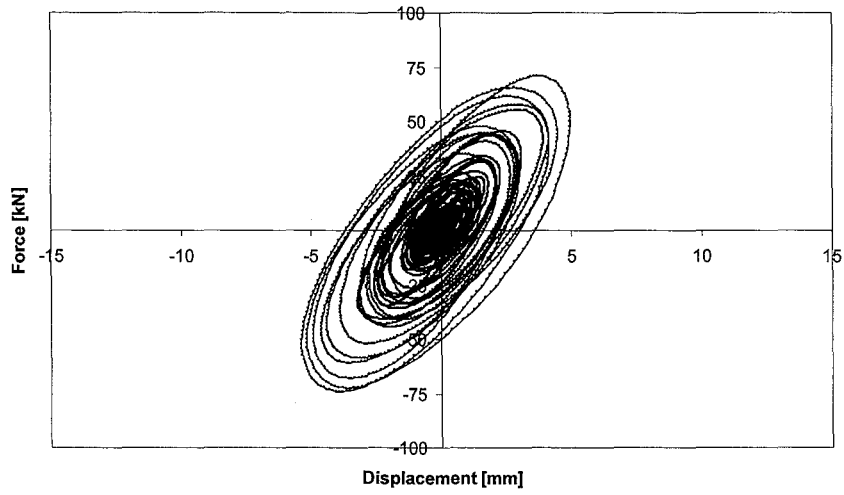


Figure 22: Force displacement relationship for Test 4.

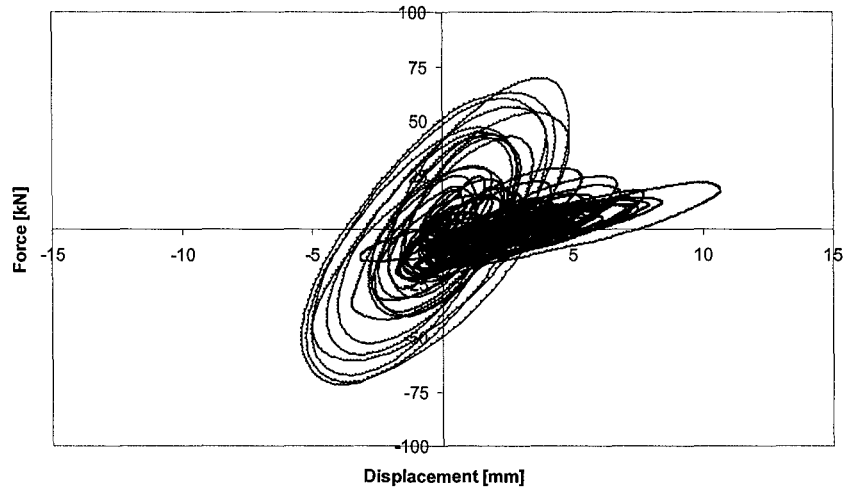


Figure 23: Force displacement relationship for Test 5.

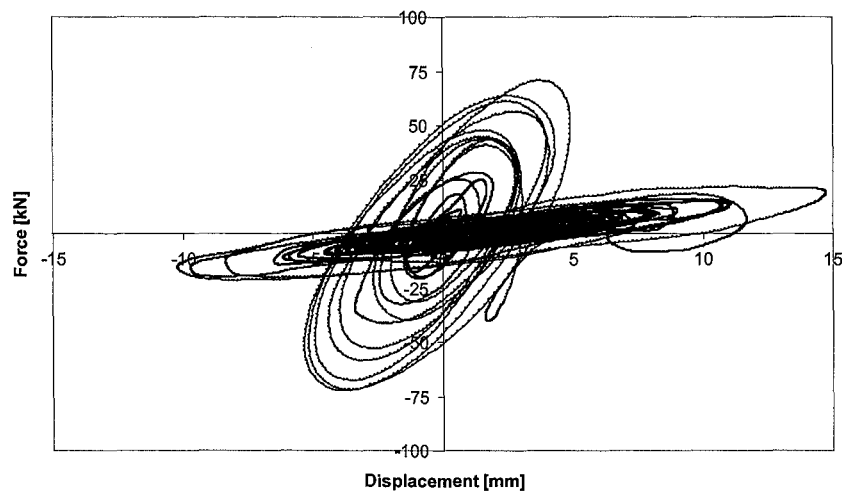
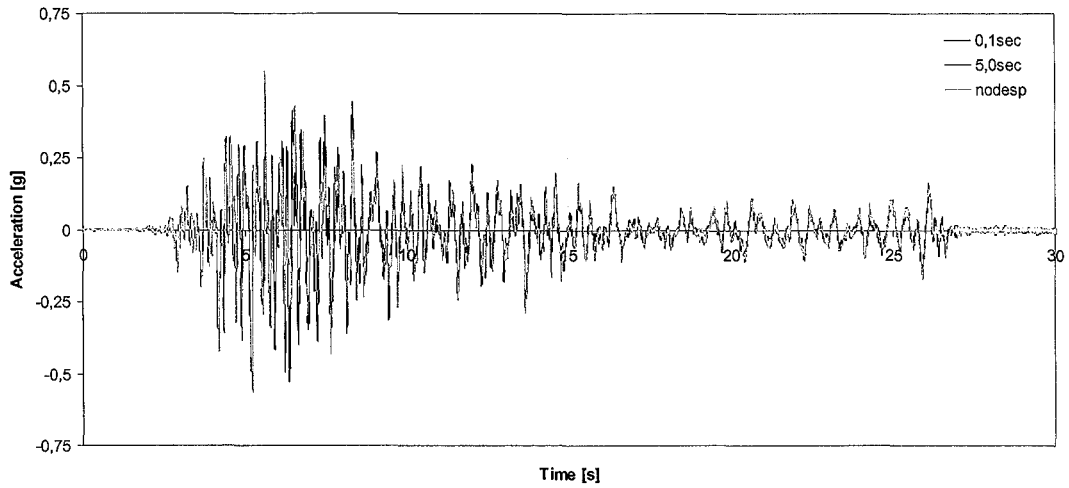


Figure 24: Force displacement relationship for Test 6.

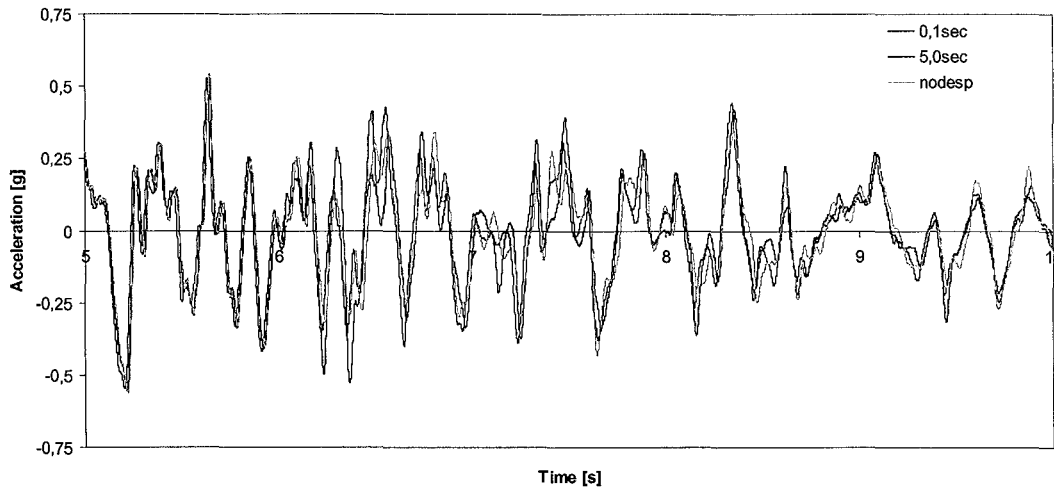


**PGA=0.6g (Tests 7, 8 and 9)**

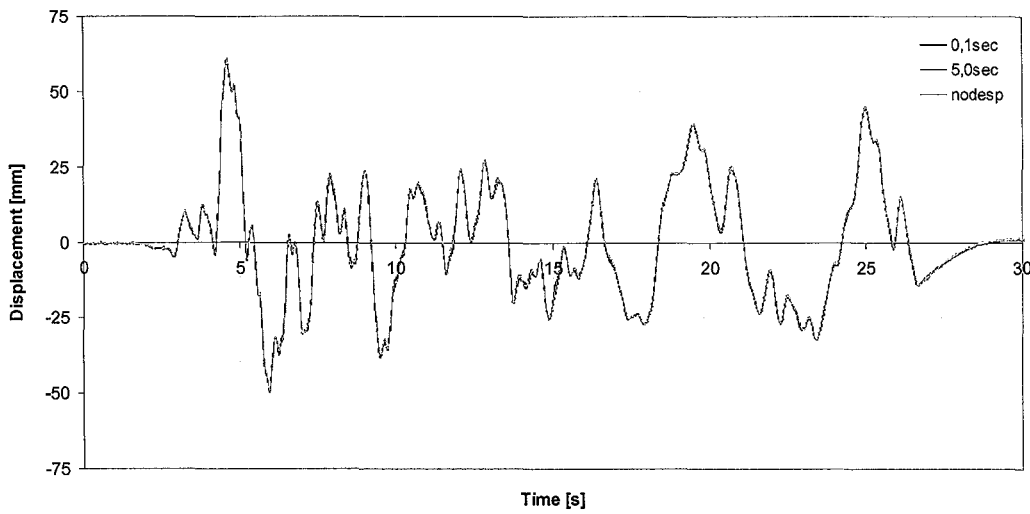




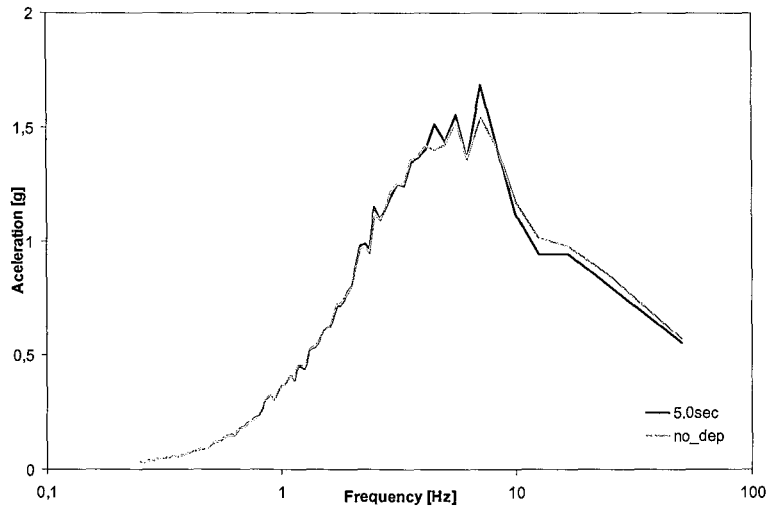
**Figure 25:** Relation between acceleration time series (Shaking table) during Tests 7 to 9.



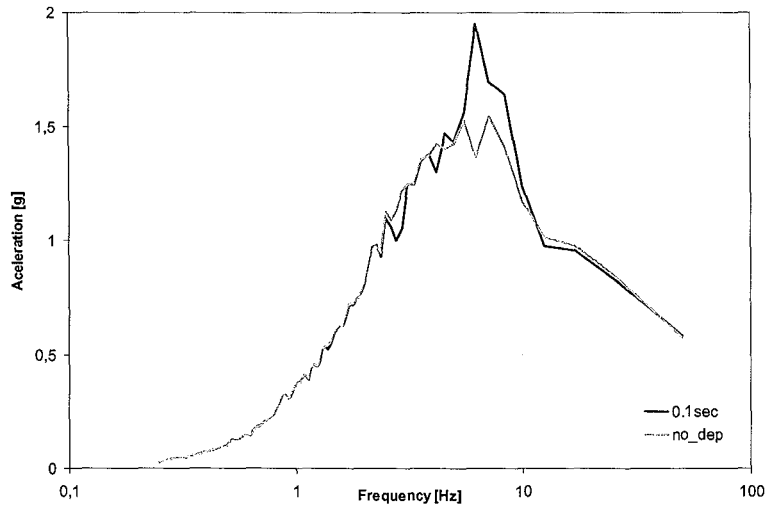
**Figure 26:** Relation between acceleration time series (Shaking table) during Tests 7 to 9 (from 5 to 10 seconds).



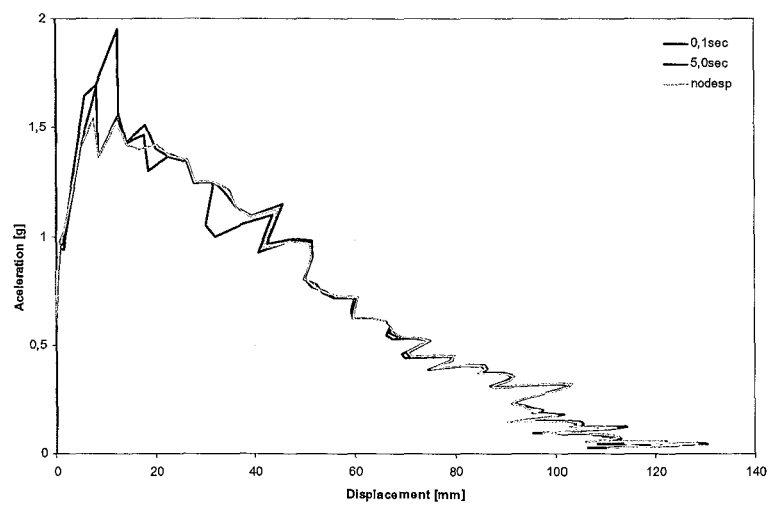
**Figure 27:** Relation between displacement time series (Shaking table) during Tests 7 to 9.



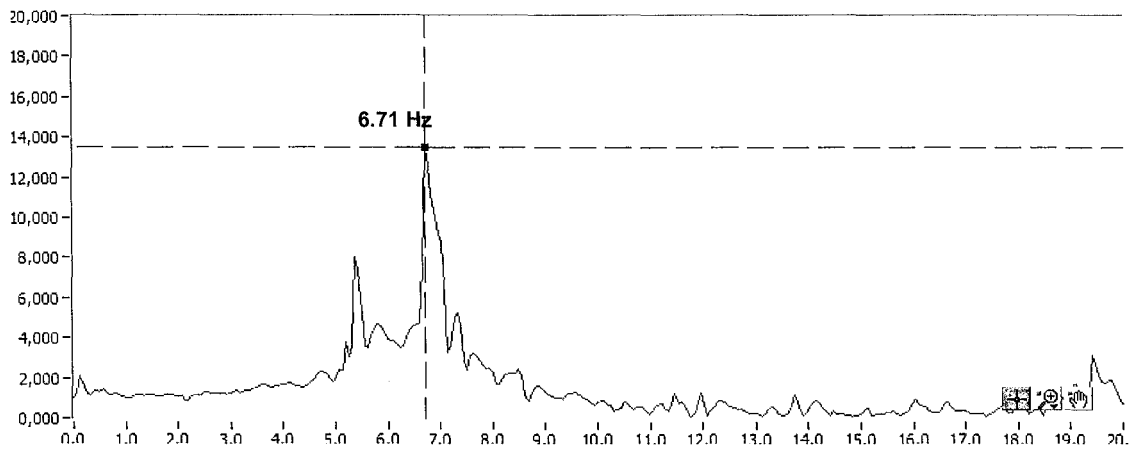
**Figure 28:** Acceleration response spectra (Shaking Table) for Tests 7 and 8.



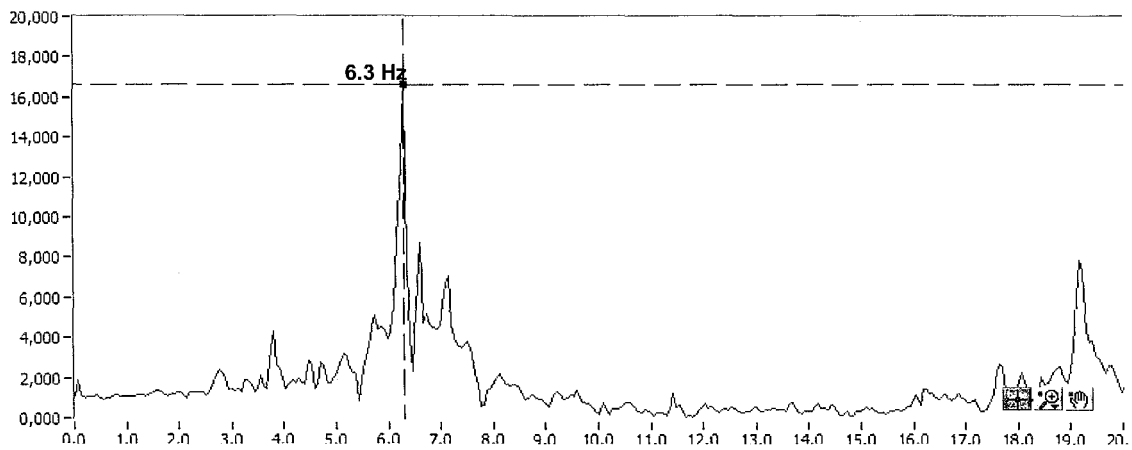
**Figure 29:** Acceleration response spectra (Shaking Table) for Tests 7 and 9.



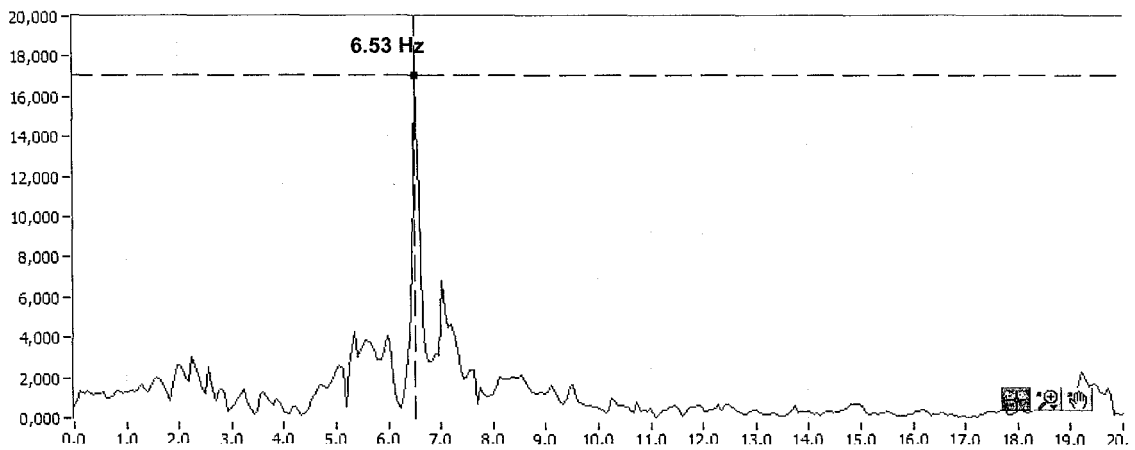
**Figure 30:** Acceleration-displacement response spectra (Shaking Table) for Tests 7 to 9.



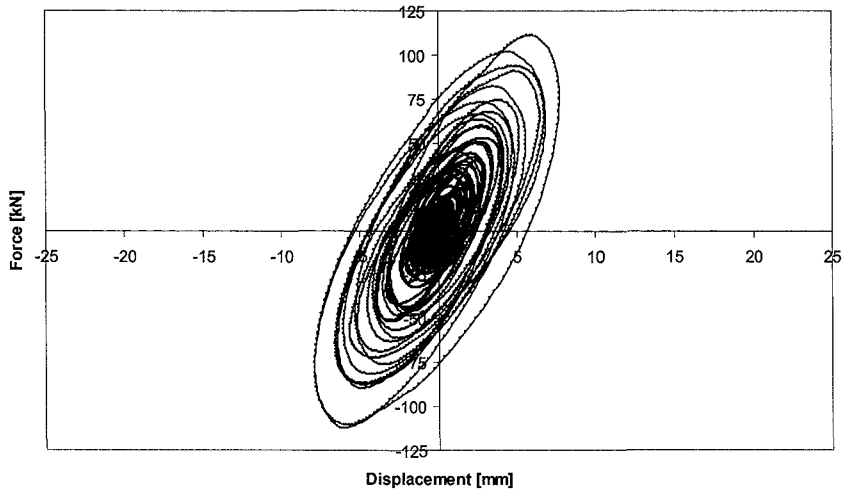
**Figure 31:** Amplitude of the transfer function between the shaking table (Table EW) and the mass of the model (A4EW) – Test 7.



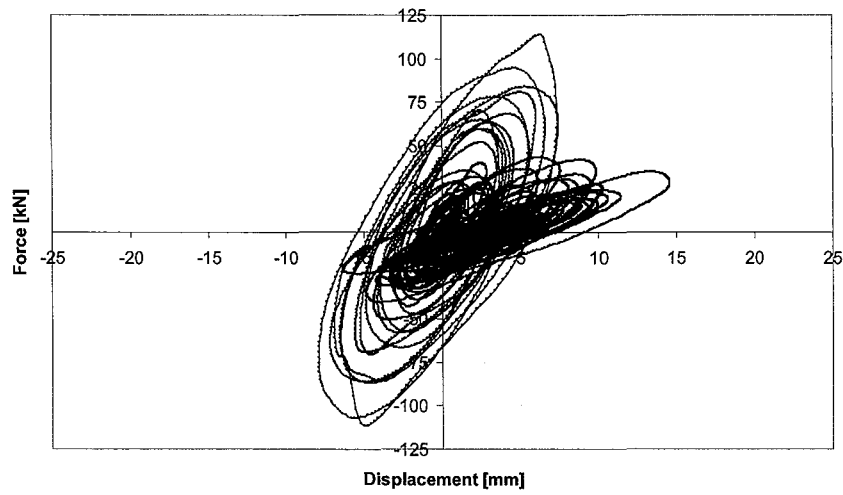
**Figure 32:** Amplitude of the transfer function between the shaking table (Table EW) and the mass of the model (A4EW) – Test 8.



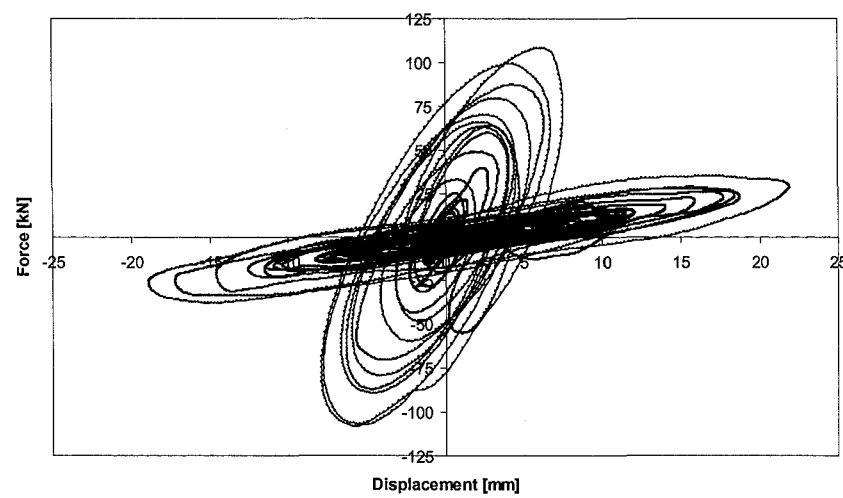
**Figure 33:** Amplitude of the transfer function between the shaking table (Table EW) and the mass of the model (A4EW) – Test 9.



**Figure 34:** Force displacement relationship for Test 7.



**Figure 35:** Force displacement relationship for Test 8.

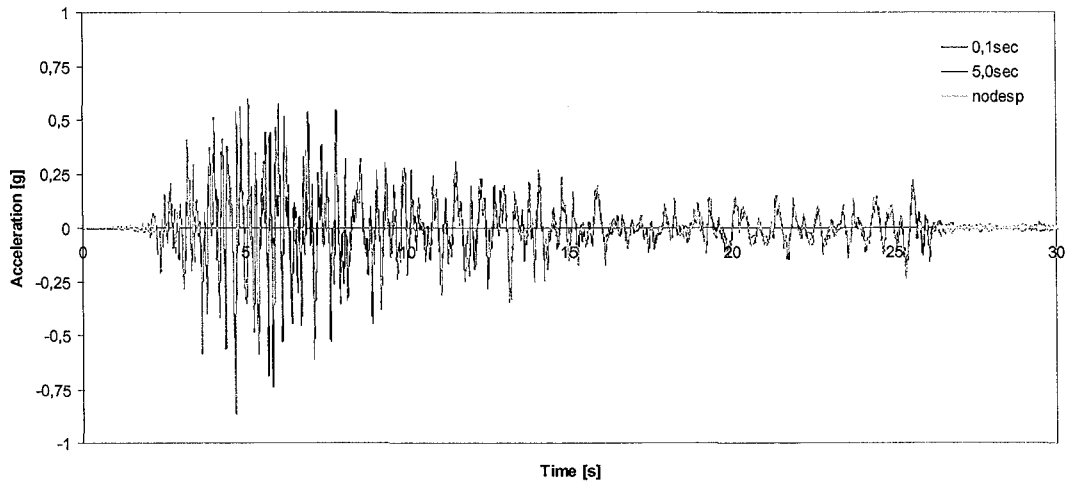


**Figure 36:** Force displacement relationship for Test 9.

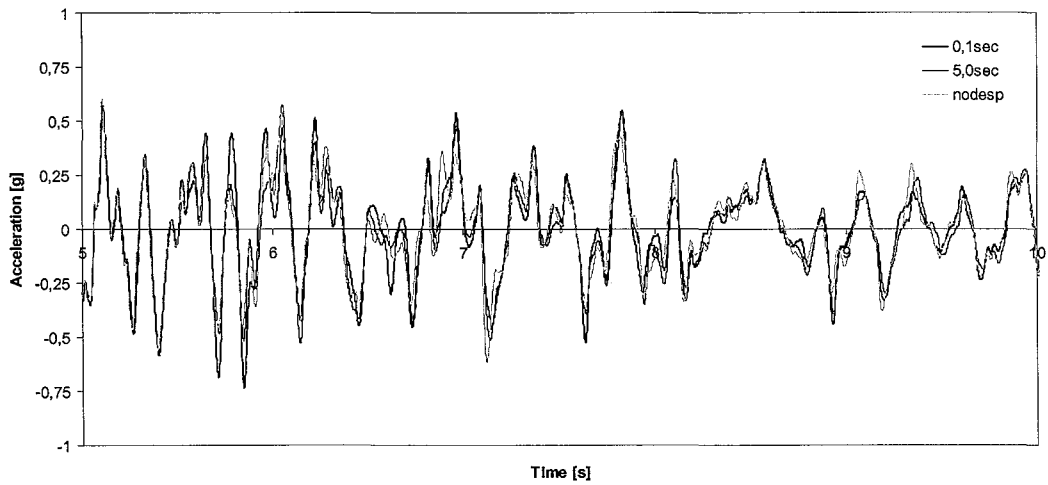
**PGA=0.8g (Tests 10, 11 and 12)**



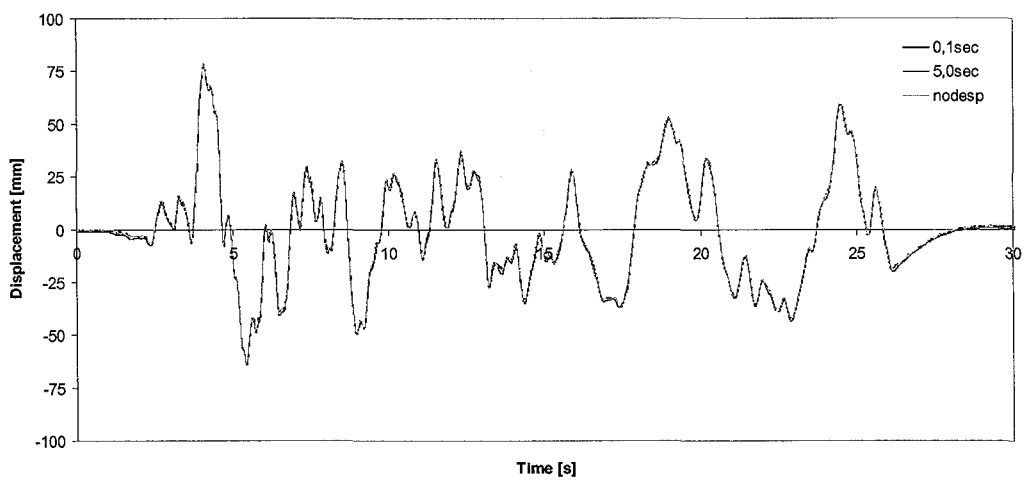




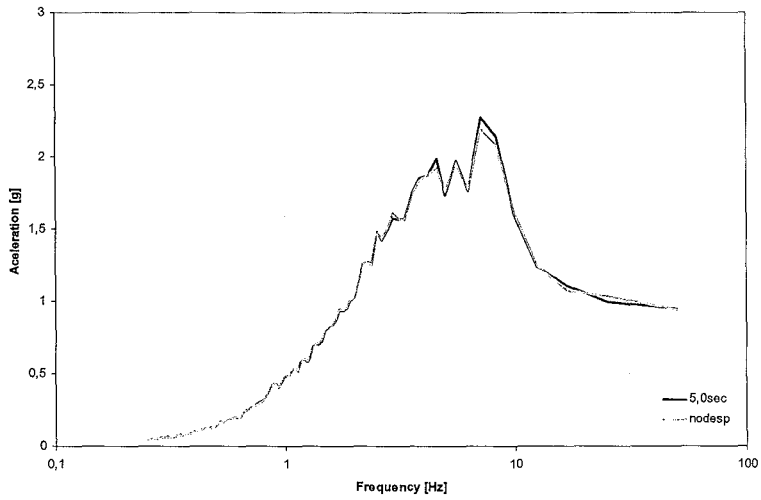
**Figure 37:** Relation between acceleration time series (Shaking table) during Tests 10 to 12.



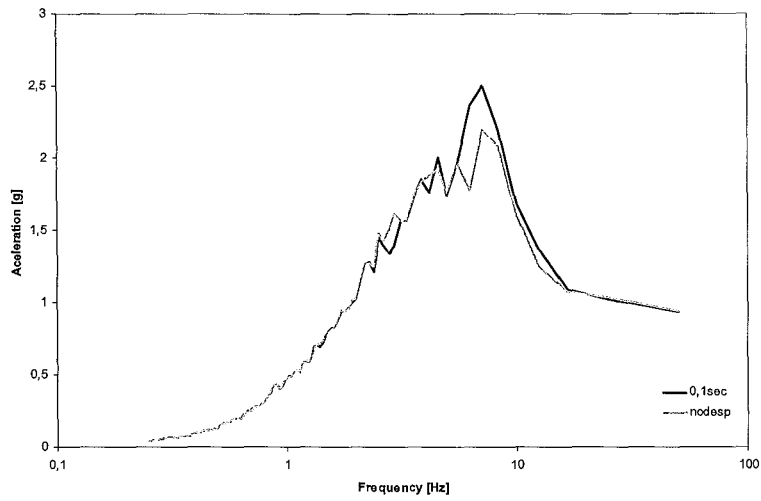
**Figure 38:** Relation between acceleration time series (Shaking table) during Tests 10 to 12 (from 5 to 10 seconds).



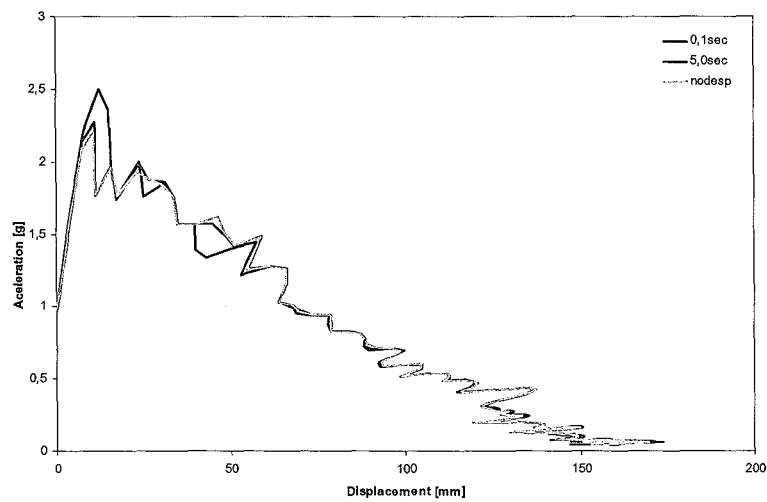
**Figure 39:** Relation between displacement time series (Shaking table) during Tests 10 to 12.



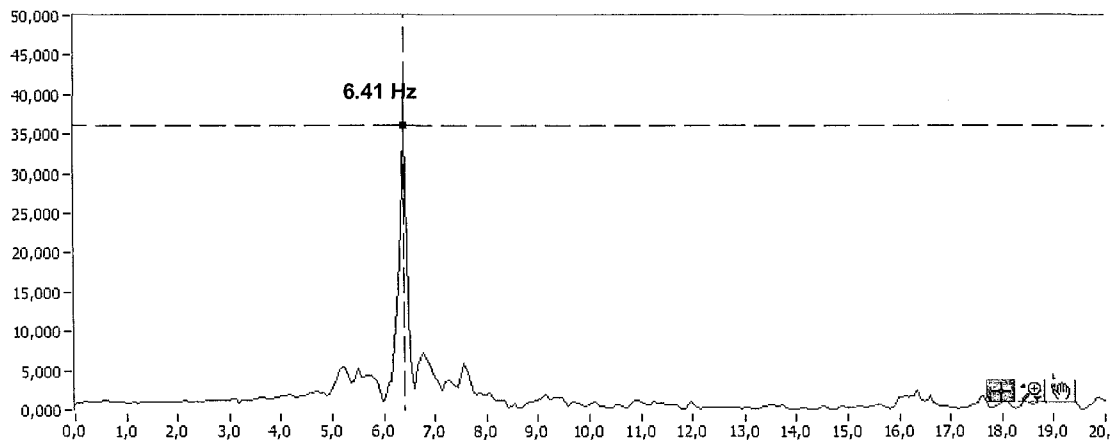
**Figure 40:** Acceleration response spectra (Shaking Table) for Tests 10 and 11.



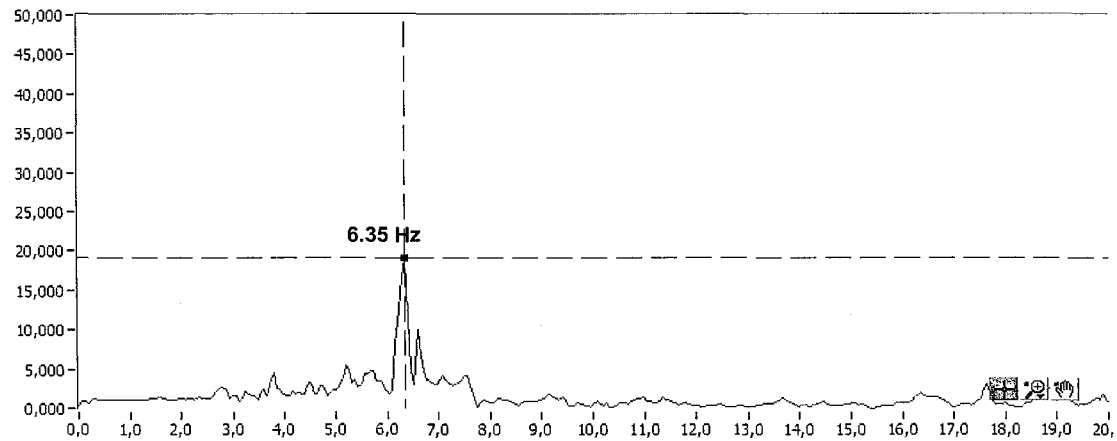
**Figure 41:** Acceleration response spectra (Shaking Table) for Tests 10 and 12.



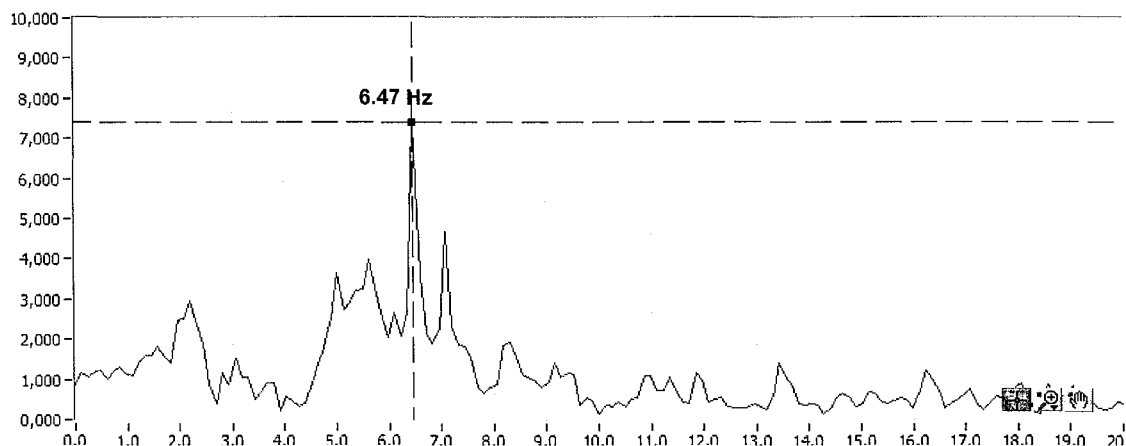
**Figure 42:** Acceleration-displacement response spectra (Shaking Table) for Tests 10 to 12.



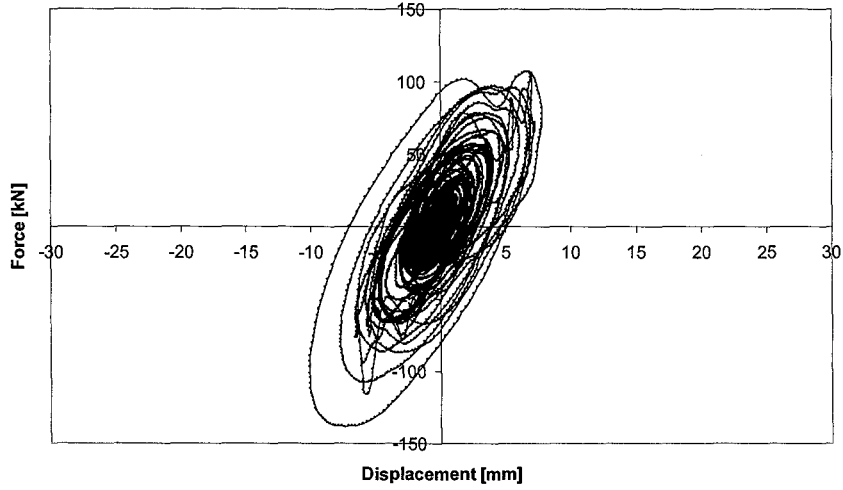
**Figure 43:** Amplitude of the transfer function between the shaking table (Table EW) and the mass of the model (A4EW) – Test 10.



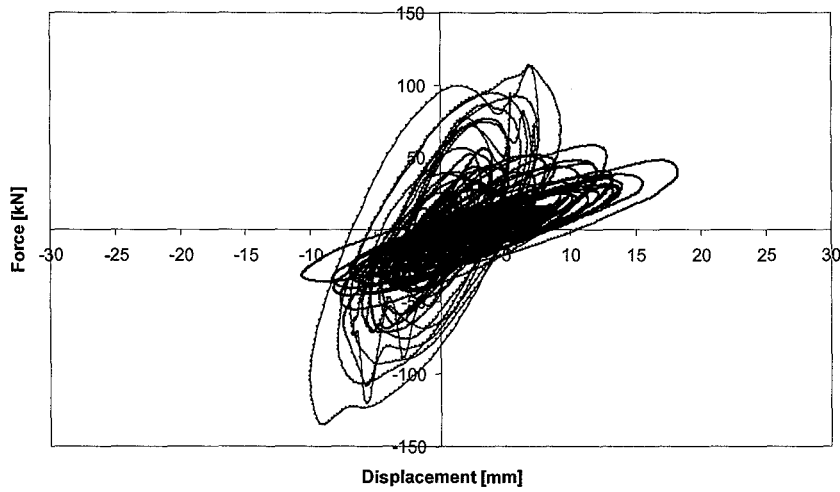
**Figure 44:** Amplitude of the transfer function between the shaking table (Table EW) and the mass of the model (A4EW) – Test 11.



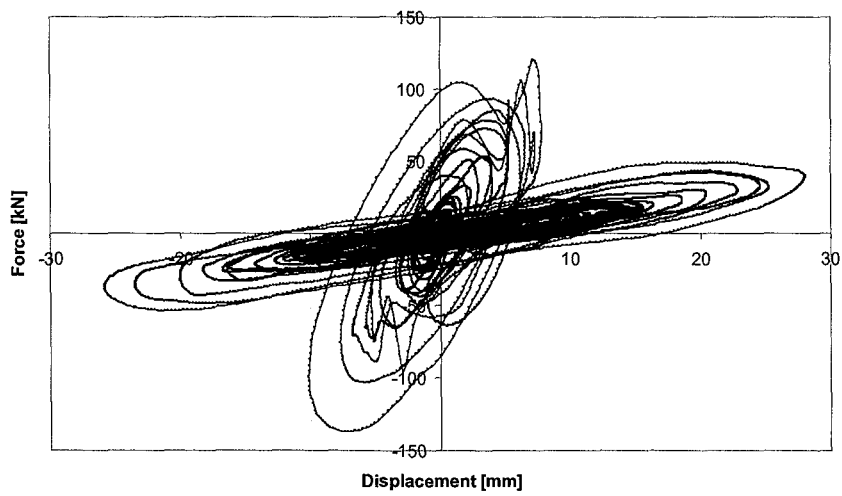
**Figure 45:** Amplitude of the transfer function between the shaking table (Table EW) and the mass of the model (A4EW) – Test 12.



**Figure 46:** Force displacement relationship for Test 10.



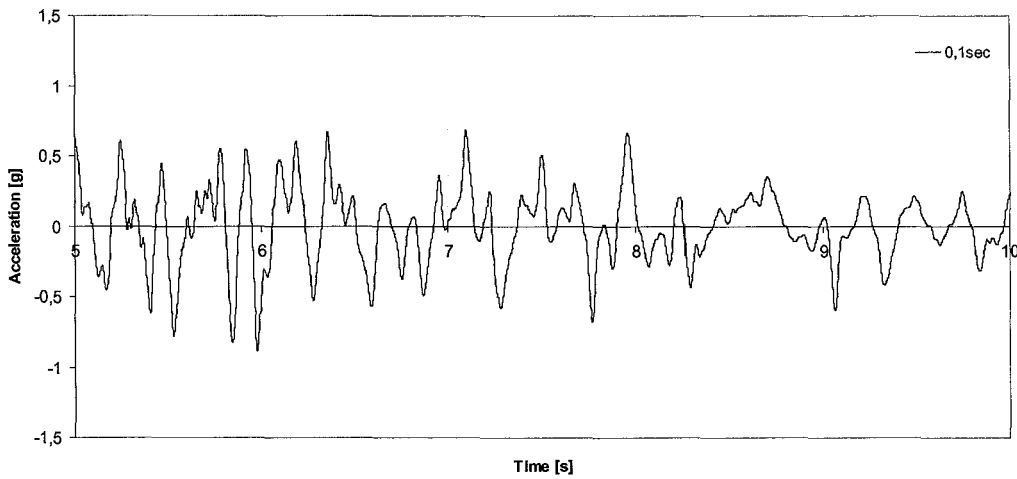
**Figure 47:** Force displacement relationship for Test 11.



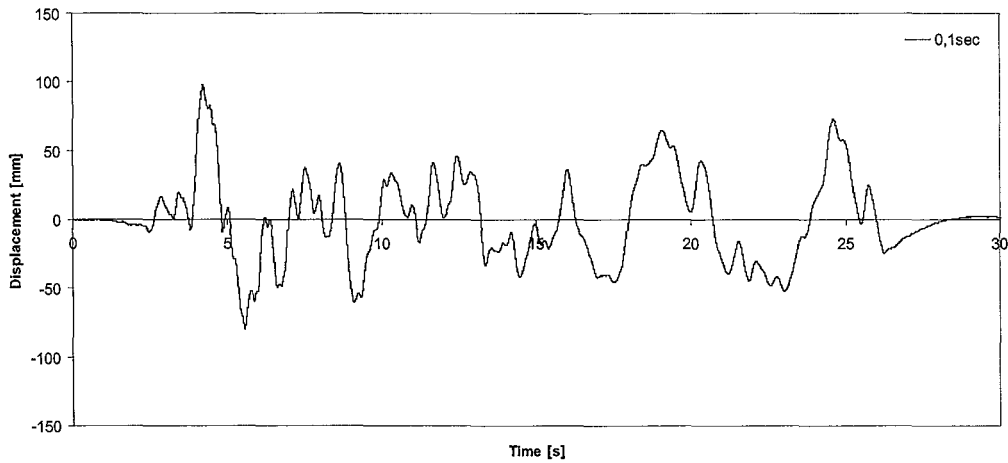
**Figure 48:** Force displacement relationship for Test 12.

**PGA=1.0g (Test 13)**

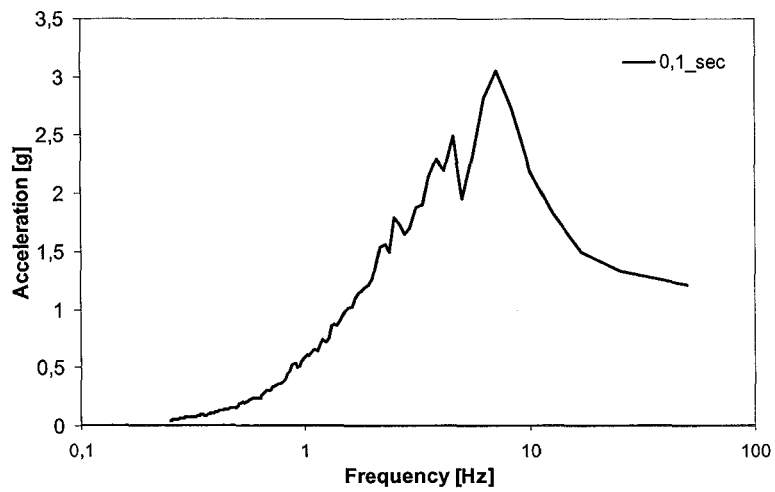




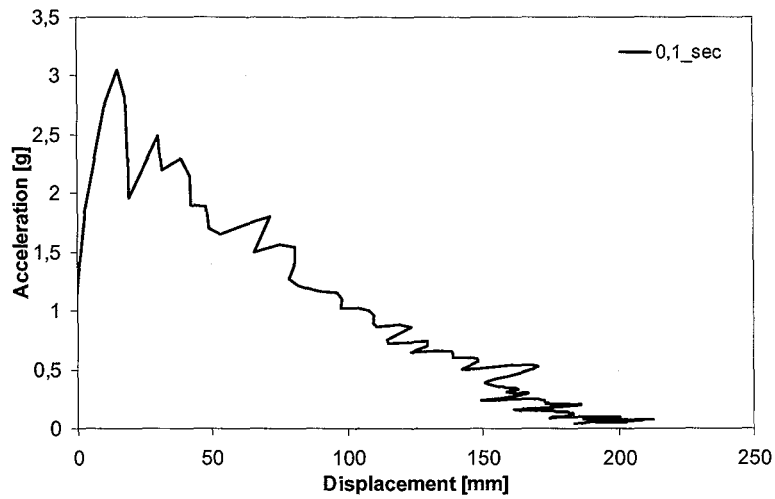
**Figure 49:** Acceleration time series (Shaking table) during Tests 13 (from 5 to 10 seconds).



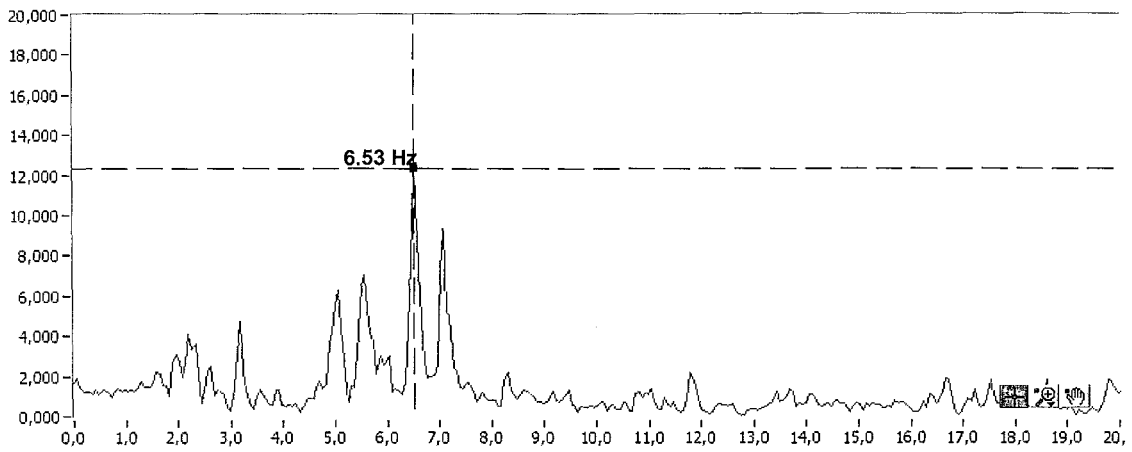
**Figure 50:** Displacement time series (Shaking table) during Tests 13.



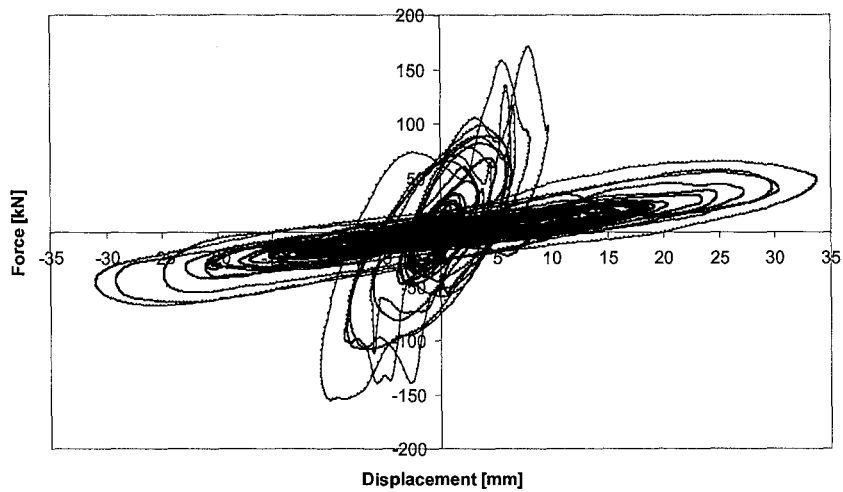
**Figure 51:** Acceleration response spectra (Shaking Table) for Test 13.



**Figure 52:** Acceleration-displacement response spectra (Shaking Table) for Test 13.



**Figure 53:** Amplitude of the transfer function between the shaking table (Table EW) and the mass of the model (A4EW) – Test 13.

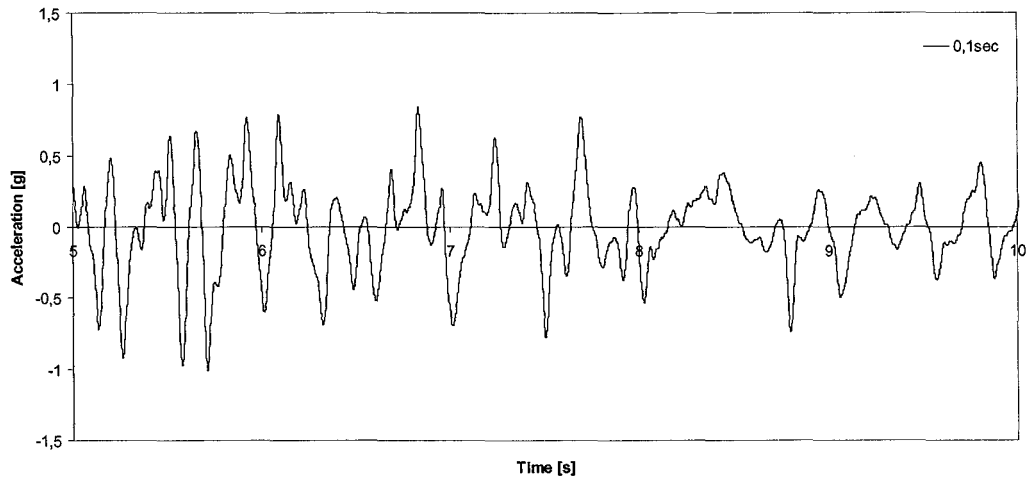


**Figure 54:** Force displacement relationship for Test 13.

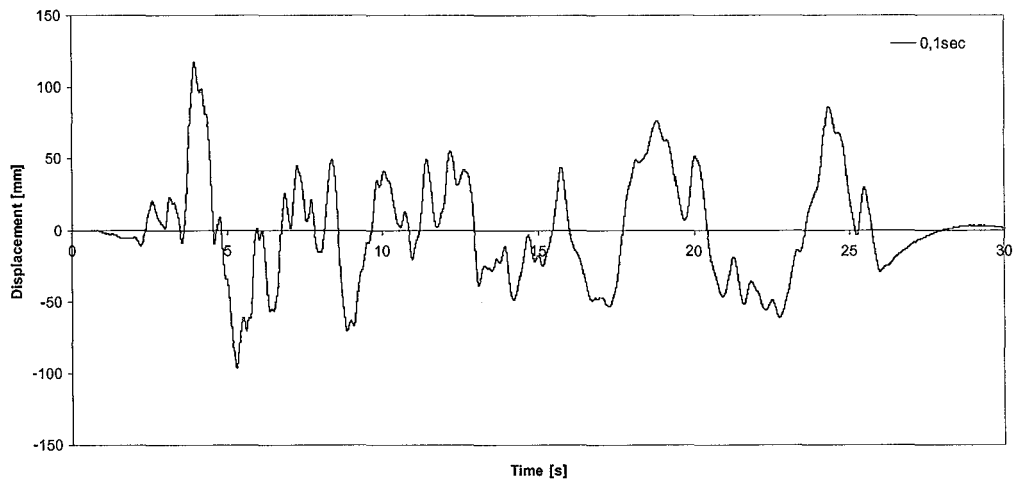


**PGA=1.2g (Test 14)**

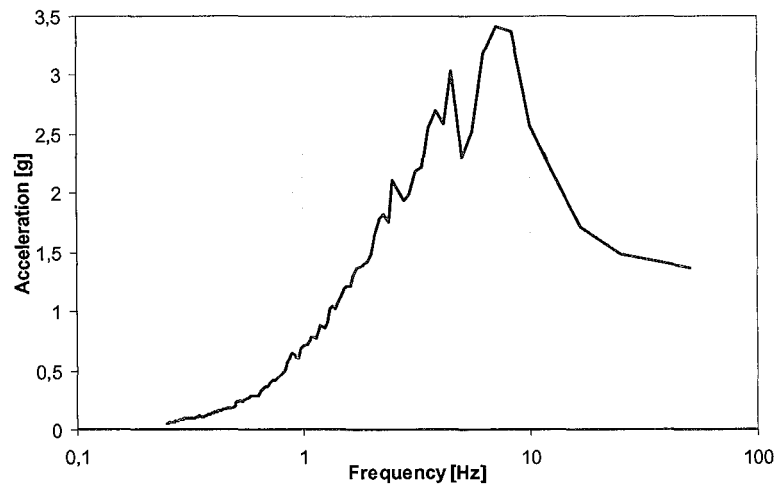




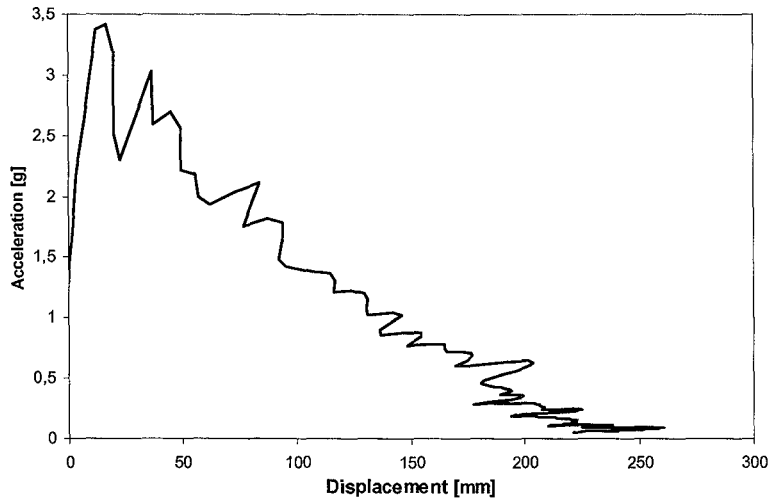
**Figure 55:** Acceleration time series (Shaking table) during Test 14 (from 5 to 10 seconds).



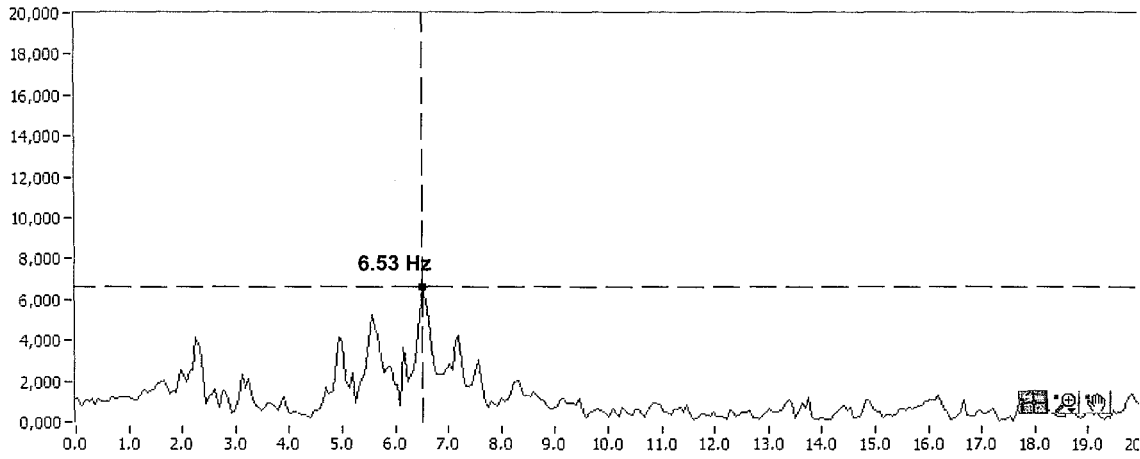
**Figure 56:** Displacement time series (Shaking table) during Test 14.



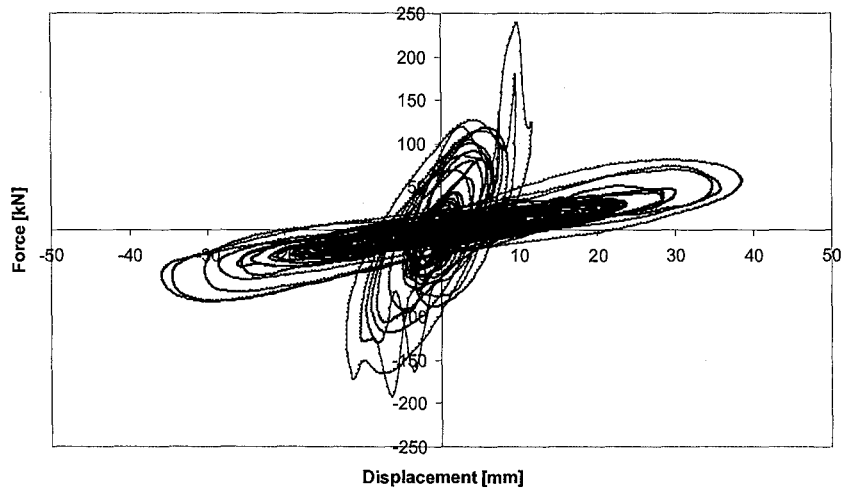
**Figure 57:** Acceleration response spectra (Shaking Table) for Test 14.



**Figure 58:** Acceleration-displacement response spectra (Shaking Table) for Test 14.



**Figure 59:** Amplitude of the transfer function between the shaking table (Table EW) and the mass of the model (A4EW) – Test 14.



**Figure 60:** Force displacement relationship for Test 14.

