

## EMBEDDED DATA ACQUISITION SYSTEM FOR EFFECTIVENESS OF LINING SYSTEMS

Pedro Miguens Matutino<sup>1</sup>, Tiago Dias<sup>1</sup>, André Cigarro<sup>1</sup>, Carlos Vitorino<sup>1</sup>, Rogério Mota<sup>2</sup>, M.Graça Lopes<sup>3</sup>, Madalena Barroso<sup>2</sup>, Rui Dóres<sup>4</sup>, Francisco Silva<sup>5</sup>

<sup>1</sup> ISEL / ADEETC <sup>2</sup> LNEC <sup>3</sup> ISEL/ADEC <sup>4</sup> EGF <sup>5</sup> APA

Lisboa, Portugal

*pmiguens@deetc.isel.pt, tdias@cc.isel.ipl.pt, 31650@alunos.isel.pt, 30264@alunos.isel.pt, rmota@lnec.pt, glopes@dec.isel.ipl.pt, mbarroso@lnec.pt, r.dores@adp.pt, francisco.silva@apambiente.pt*

**Keywords:** Data acquisition, embedded system, lining systems, defect detection.

**Abstract:** This paper presents an embedded data acquisition system for the mobile probe liner integrity survey method using one matrix of electrodes. The mobile probe is used for landfill fault detection on barriers systems. These barriers are used in the construction of landfills, in order to assure the protection of the environment. Such faults are produced during the construction process and it is impossible to avoid them. Consequently, accurate test methods are required to check the integrity of the barriers after the placement of the granular layer. In this paper, a prototype of an embedded data acquisition system that allows the implementation of a quick and low-cost test method is proposed.

### 1 INTRODUCTION

Landfills are engineering facilities designed and constructed with a barrier system (lining system) intended to assure the protection of the environment. Figure 1 shows one of these systems, which typically include both active and passive barriers.



Figure 1: Landfill facility with a barrier system.

The passive barriers comprise a Compacted Clay Liner (CCL) and/or a Geosynthetic Clay Liner (GCL), while the active barriers includes a Geomembrane (GM), protected by a Geotextile (GTX), and a

drainage layer known as Primary Leachate Collection System (PLCS), as depicted in Figure 2.

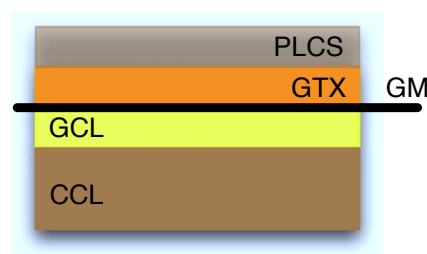

Figure 2: Landfill cut with a barrier system.

The effectiveness of lining systems in service conditions depends, above all, on the performance of the GM. A critical issue for its performance are the defects that, unfortunately, are unavoidable. Most of such defects appear during the placement of the PLCS [1, 2]. Indeed, data collected at more than 300 sites in 16 countries revealed that 71% of the damages were caused by stones during the PLCS installation [3]. Moreover, according to these authors, the number of defects per hectare is about 12.9, where as [4] refers a value of 17.4 defects/ha. It should be noted that these values concern to GMs installed un-

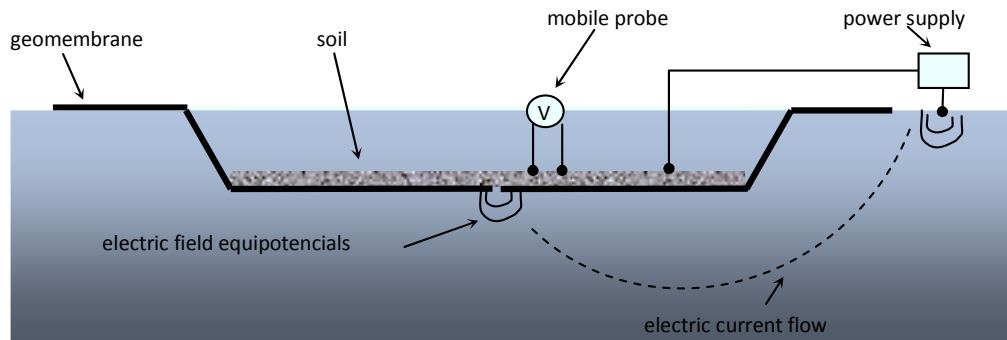

Figure 3: Mobile probe line integrity survey method.

der strict Construction Quality Assurance (CQA) programmes. Higher values can be expected in landfills without CQA.

Although there are some test methods do detect and locate defects in GM liners after the placement of the PLCS [5], namely the soil-covered GM method (or mobile probe) [6] and the permanent grid method, such methods present some disadvantages. They are labour and time consuming and therefore very expensive.

The mobile probe liner integrity survey method (Figure 3) uses two pairs of electrodes to detect defaults: one fixed for power injection and the other mounted on a mobile unit, which is used to survey point by point, all the basement of the landfill. In an uniform medium, while the mobile probe gets away from the injection point the voltage measured drops as the potential decreases with distance. However, in the presence of a near hole/defect the voltage measure raises, as it is depicted in Figure 4. This method is highly dependent on the skills of the system operator, and can be not very precise in terms of area coverage.

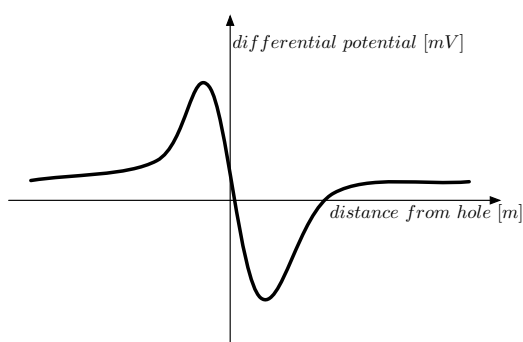

Figure 4: Electrical potential variation near a hole/defect.

These conditions motivated us to the development of a quick and low-cost, but also accurate test method

to check the integrity of the GMs after the placement of the granular layer (PLCS). The proposed methodology consists in the development of a prototype of a defect detection system combining the mobile probe method with multi-probes, a similar approach to the one adopted by multi-cables resistivity equipments currently used for geophysical surveys.

In this paper an improved methodology is considered to acquire the data of the landfill survey, namely, we propose an autonomous embedded system for data acquisition and information storage. Our approach is similar to the mobile probe liner integrity survey, but instead of using a single probe with two electrodes it uses a matrix of electrodes to detect defects, where only two of them are selected in each acquiring step.

The rest of this paper is organized as follows. The next section presents the architecture of the proposed system. Section 3 describes the implementation details of the hardware and the software modules integrating a prototype of the developed embedded data acquisition system. Section 4 discusses the preliminary experimental results obtained with the proposed data acquisition system. Finally, in section 5, the conclusions of this work are presented, as well as some guidelines for future work.

## 2 SYSTEM ARCHITECTURE

The proposed data acquisition system, whose block diagram is depicted in Figure 5, is composed of five different modules, namely a: *i*) processing module, *ii*) human interface, *iii*) data storage, *iv*) electrodes switching module, *v*) signal conditioning module. The first three blocks are very tightly coupled and form the system Data Processing and Human Interface (DPHI) module.

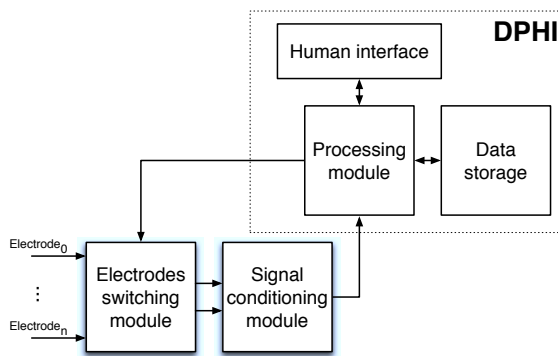

Figure 5: Proposed system architecture.

The processing module consists of an ARM processor and is used to control the whole system, as well as to process all the acquired data. A pair of electrodes, which are selected by the switching electrodes module, captures such data that is subsequently pre-processed by the signal conditioning module. This module converts the electrical potential difference between the two electrodes into the digital domain, by using an analog-to-digital converter (ADC). The processed data is then stored in an SD card, which is part of the data storage module. User commands are given using one touch-screen monitor, which is also used to display the system information. These devices are part of the Human Interface module.

### 3 IMPLEMENTATION

In this section it is presented the logical structure of the application implementing the proposed data acquisition system. More specifically, the logical structure of the system, which is depicted in Figure 6, is presented and the implementation options for its 3 main blocks, namely the DPHI, the signal conditioning and the electrodes switching module, are described in detailed.

#### 3.1 Data Processing and Human Interface (DPHI)

The developed prototype of the proposed system is based on the Bluescreen [7] board, which is used to implement the DPHI block of the conceived data acquisition system. This development board has an ARM7 LPC2378 micro-controller, a resistive type 2.8 inches touch screen TFT LCD with 240x320 pixels of resolution and 8kB on board EEPROM. The considered peripheral interfaces were the SPI (Serial Periph-

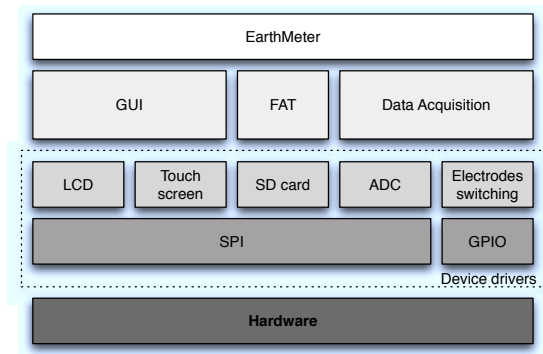

Figure 6: Software structure.

eral Interface) and the 16 bit General Purpose Input Output (GPIO) port, that as 3.3 V TTL interface and is 5 V tolerant. Furthermore, a micro-SD card socket connected via the SPI interface is also available, supporting up to 2GB of storage capacity.

The EarthMeter application has been implemented using a modular structure, as it can be seen in Figure 6. Using this approach, each hardware device is mapped into a device driver software module that is used as an interface between the application and the devices. Regarding to the application itself, it consists of a stand alone program with a relatively simple functionality. Such functionality consists in allowing the user to select the configuration file containing the sequence of electrodes used in the fault detection search. In addition it allows the user to start/stop the acquisition process and to store the obtained measures in the SD card. All the user commands are sent to the system using the touch screen functionality, while system responses are shown to the user using the LCD. These operations are supported by the developed Graphical User Interface (GUI) software module. The FAT module implements an optimized version for embedded systems of the FAT16 file system, in order to support the reading and writing of data in the SD card. Finally, the Data Acquisition module implements the communication protocol supported by the signal conditioning and the electrodes switching modules, which are presented in section 3.3.

As it can be seen, the complexity of this approach is quite modest, which is why EarthMeter was implemented as cooperative state machine application. This allows to significantly reduce the required amount of memory and processor usage, that are very important factors to take into consideration when developing a portable or battery supplied embedded system.

### 3.2 Signal conditioning module

This module converts the electrical potential difference between the two electrodes into the digital domain, by using an analog-to-digital converter (ADC). Considering, that the maximum voltage injected by the fixed power supply unit is +300 V, the difference in potential between two electrodes ( $V_{diff}$ ) is in the range [-300; +300] V. Typically, ADCs have an input range of 0 to  $V_{ref}$ , and for the considered system the value of this reference voltage is 3.3 V.

In order to adequate  $V_{diff}$  to the input range of the ADC, it is necessary to implement a conditioning circuit with a gain factor less than 1, which reduces the input values to the magnitude of  $V_{ref}$ . The proposed

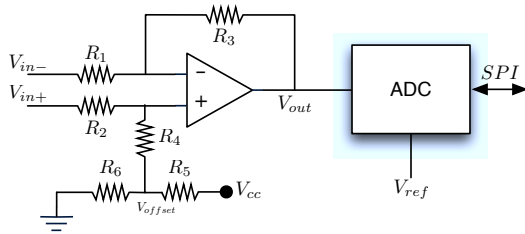

Figure 7: Signal conditioning circuit.

conditioning circuit is based on a differential amplifier, as shown in Figure 7, and it is characterized by the following equations.

The output value of an operational amplifier is given by:

$$V_{out} = V_{in+} + V_{in-} . \quad (1)$$

$V_{out}$  can be rewritten using the superposition theorem as:

$$V_{in+} \rightarrow V_{out} = \frac{R_4}{R_4 + R_2} V_{in+} \quad (2)$$

$$V_{in-} \rightarrow V_{out} = -\frac{R_3}{R_3 + R_1} V_{in-} \quad (3)$$

$$V_{offset} \rightarrow V_{out} = \frac{R_2}{R_2 + R_4} V_{offset} \quad (4)$$

$$V_{offset} = \frac{R_6}{R_6 + R_5} V_{cc} \quad (5)$$

$$V_{out} = \left( \frac{R_4}{R_4 + R_2} V_{in+} - \frac{R_3}{R_3 + R_1} V_{in-} \right) + \frac{R_2}{R_2 + R_4} V_{offset} . \quad (6)$$

For this particularly case, the contribution for each input branch has to be the same. Resistors  $R_1$ ,  $R_3$  and  $R_2$ ,  $R_4$  set the gain of negative and of the positive branch, respectively. Also, the  $V_{offset}$  value has

to be transposed to the output value. These restrictions results in:

$$\frac{R_4}{R_4 + R_2} = \frac{R_3}{R_3 + R_1} = \frac{V_{ref}}{600} \quad (7)$$

$$\frac{R_2}{R_2 + R_4} = 1 \quad (8)$$

$$R_1 = R_2 \quad (9)$$

$$R_3 = R_4 \quad (10)$$

$$R_2 \gg R_4 . \quad (11)$$

Considering that the reference voltage ( $V_{ref}$ ) of the ADC and  $V_{cc}$  are 3.3 V, the value of  $V_{offset}$  has to be 1.5 V. Consequently, the adopted resistors values are:

$$R_1 = R_2 = 2.2M\Omega \quad (12)$$

$$R_3 = R_4 = 11K\Omega \quad (13)$$

$$R_5 = 100\Omega \quad (14)$$

$$R_6 = 83.3\Omega . \quad (15)$$

Regarding to the operational amplifier, the MAX4460ESA+ [8] rail-to-rail instrumentation amplifier was used to develop the proposed system prototype. This amplifier has low-power consumption, an excellent gain-bandwidth characteristic, allows ground-sensing capability combined with ultra-low input current and increased common-mode rejection performance.

The output signal of the operational amplifier ( $V_{out}$ ) is fed into a SPI ADC to be converted to the digital domain. The considered ADC device was the MCP3201 [9] from Microchip Technology Inc., which has an SPI interface. Moreover, this ADC has an on-chip sample and hold circuit supporting sampling rates up to 100 ksp/s, using a clock frequency of 1.6 MHz, and implements a successive approximation analog-to-digital conversion method with 12-bit resolution. This is enough resolution and sampling rate to our application requirements.

The proposed signal conditioning module includes also some ILD74 [10] optocoupler devices, in order to opto-isolated the communication with the DPHI module. This provides over-voltage protection to the operator of the lining system.

### 3.3 Electrodes switching module

The switching module is responsible for selecting the electrodes to be connected to the signal conditioning module. Considering this functionality, each electrode has three possible connections: *i*) connected to the positive input of the signal conditioning module ( $V_{in+}$ ), *ii*) connected to negative input of the module ( $V_{in-}$ ), and *iii*) not connected to any input.

The proposed switching circuit for one electrode is composed by two Solid State Relays (SSRs), and two independent control circuits, as it is shown in Figure 8. To connect the electrode to  $V_{in+}$  or to  $V_{in-}$  the

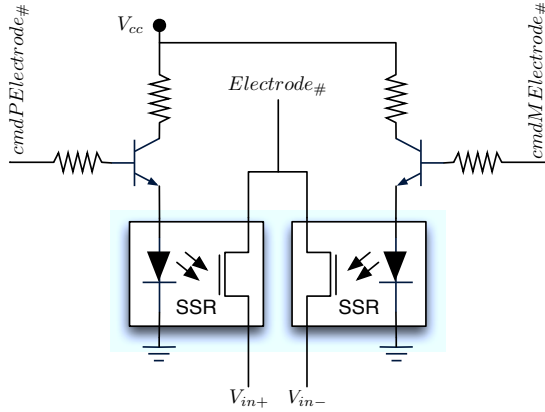

Figure 8: Switching circuit for 1 electrode.

control signals  $cmdPElectrode\#$  or  $cmdMElectrode\#$  has to be activated, respectively. When both control signals are inactive the electrode is in the disconnected configuration. Conversely, if both signals are simultaneously active the electrode is connected to the two inputs of the signal conditioning module. Consequently, output value is  $V_{offset}$ , meaning that the differential potential is zero. This configuration can be used to calibrate the data acquisition system.

The switching circuit has been designed using SSRs, so as to replace the typical electromechanical relays and thus to avoid their mechanical problems. The adopted SSR devices [11] are Single Pole Double Throw Relay (SPST) normally open switches. These use GaAIAs LED for actuation control and an integrated monolithic die for the switch output. Such circuits are fabricated in a high-voltage dielectrically isolated technology. In addition, over-voltage protection is provided by the current-limiting circuit, which meets the FCC 68.302 and other regulatory voltage surge requirements.

The electrodes switching module consists of several electrodes combined in an array, with their switching circuits and one interface/controller circuit. Our proposal is based on a switching block of 16 electrodes configured as depicted in Figure 9.

Considering such design, it is necessary to implement a parallel interface with 32 bits for control. However, this interface is not scalable and uses a great amount of the GPIO pins of the processing module. In order to implement a more scalable interface, a serial interface was adopted for the switching-block. Our proposal is based on a shift register to propagate the

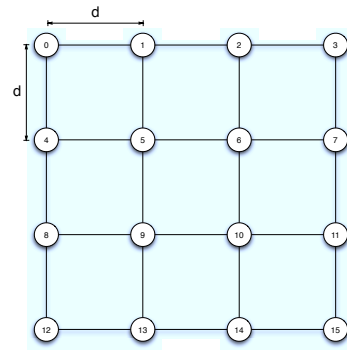
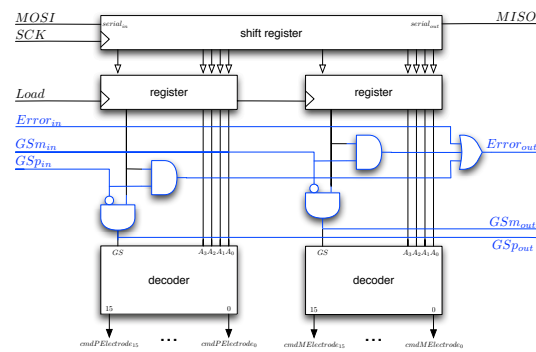
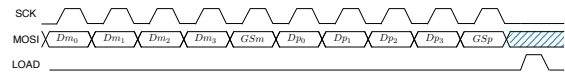

Figure 9: 16 electrodes block configuration.



(a) Block diagram



(b) Temporal diagram

Figure 10: Serial receiving and electrode decode

configuration across the entire block chain. Another register is used to store the configuration to be decoded, that allows getting the difference in potential between the two selected electrodes. Furthermore, this type of implementation allows to simultaneously acquire one measure and propagate the next selection bits across the block chain. In addition, *Group Select* and *Error* signals are propagated across the block chain, in order to avoid the selection of more than two electrodes among different boards. The *Error* signal is used to detect if more than one group select is made across different switching boards by the processing module. Also, this solution avoids the possibility of having two electrodes simultaneously connected to one input of the signal conditioning module. The proposed interface controller (depicted in Figure 10) was implemented in an ATF1504 programmable logic de-

vice (CPLD) from ATMEL.

Finally, it is worth mentioning that the proposed switching block is also scalable and easily replicable, since we intend to support multiple configurations of the system. This scalability allows conjugating more than one switching block and simultaneously maintaining the same functionality. In Figure 11 it is depicted a 64 electrode configuration.

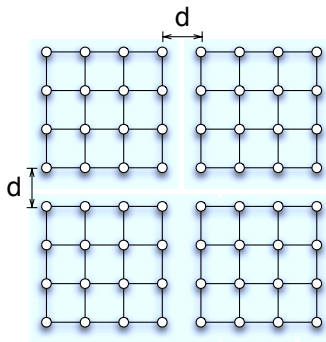

Figure 11: 64 electrode block configuration.

## 4 EXPERIMENTAL RESULTS

To validate the functionality and assess the accuracy of the developed data acquisition system, a prototype of the complete proposed fault detection system was developed. This prototype is depicted in Figure 13 and consists not only of the Bluescreen platform implementing DPHI, but also of the mechanical structure implementing the mobile unit that support the electrodes structure and the data acquisition system.

In what concerns to the functionality of the data acquisition system, the tests that were performed in laboratory allowed to conclude that the developed application complies with the specified requirements. Namely, it was programmed to successfully use the touch-screen LCD monitor to interact with the user, as well as the SD card interface to retrieve the configurations of the electrode array from the data acquisition procedure and to store such data in the SD card. The performed tests also proved that the DPHI module is capable to program the electrodes switching module, to implement the designed electrodes array configurations, and to command it in order to obtain the electrical potential variations reported by the electrodes. This has been verified for several configurations of the electrodes array.

Regarding to the signal conditioning module, the set of tests that were realized was much more com-

prehensive, in order to assure the accuracy of the data acquisition system. To achieve such goal, the following two-steps methodology was adopted: in the first step, the data acquisition system was calibrated adjusting the zero offset, and subsequently several different measures were executed. The calibration process consisted in connecting the same electrode to the  $V_{in+}$  and  $V_{in-}$  inputs of the signal conditioning, and fine-tuning the  $R_6$  value until  $V_{out}$  reached the desired offset value. In the second step, an external power supply was connected to the two electrodes and its output voltage was varied in the range -300 V to +300 V, in order to obtain the practical characteristic of the signal conditioning module. Figure 12 depicts these experimental results, as well as the predicted theoretic response of this module.

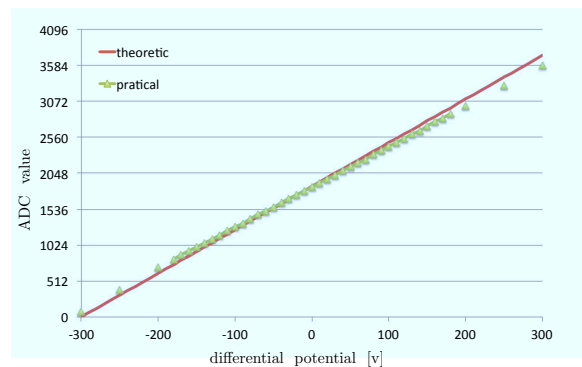

Figure 12: Characteristic of the signal conditioning module.

The differences observed in Figure 12 are owed to the Differential Nonlinearity (DNL) and the Integral Nonlinearity (INL) of the ADC [9], which are about  $\pm 1$  LSB. Consequently, this behaviour was corrected in the software application, by introducing a correction factor in the ADC software block that is configured during the system calibration process.

## 5 CONCLUSIONS

An innovative embedded data acquisition system for an improved mobile probe liner integrity survey method is proposed in this paper. The modifications introduced in the presented improved survey method consists of using a matrix of 4x4 electrodes to speed up the data acquisition task. Nevertheless, the proposed system presents a scalable architecture that further allows extending the number acquisition points by replicating the amount of arrays of 4x4 electrodes. This feature is especially relevant not only when large search areas are considered, since it allows to signif-



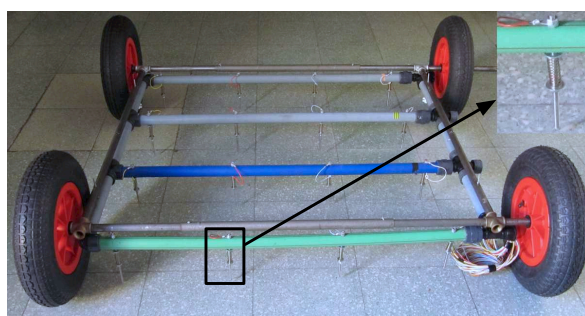

(a) 16 Electrodes structure

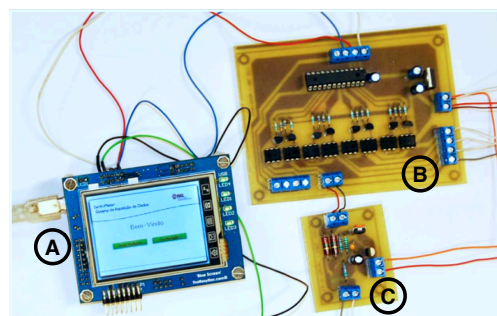

(b) Data acquisition system: A - PDI; B - Electrodes switching; C - Signal conditioning

Figure 13: System prototype

icantly reduce the computation time, but also to augment the precision of the search procedure by shortening the step space between the electrodes.

The functionality of the prototype has been verified at laboratory with different types of lining systems and defects. The obtained experimental results are good and consistent. A bigger scale plant is currently being constructed to verify, at real scale, the functionality and accuracy. Afterwards, it will be checked *in situ*, at a true landfill.

As future work, a geographic positioning device will be integrated with this embedded system. More specifically, a GPS (Global Positioning System) with Real Time Kinetic (RTK) capability shall be used to allow accessing the position of the defect with better accuracy. With the proposed system, it becomes possible to assure that all landfill basement was covered on each survey, not relying only on the skills of the operator, and that such data is recorded on a SD card for later utilization. This information can be used to know the precise location of the defects, as well as to generate complete quality control documentation. These facts give good perspectives for on site application, therefore allowing a higher use of liner integrity surveys and assessments as part of the quality control program in the construction of a landfill, which ultimately benefits the environment.

## ACKNOWLEDGEMENTS

This work was supported by the Portuguese Foundation for Science and for Technology under the grant PTDC/AAC-AMB/102846/2008.

## REFERENCES

- [1] N. TouzeFoltz M. Barroso and M.G. Lopes. Rate of liquid flow through composite liners due to defects in the geomembrane: Recent advances. *2nd Portuguese Seminar on Geosynthetics*, pages 239–259, 2007.
- [2] P. Colucci and M.C. Lavagnolo. Three years field experience in electrical control of synthetic landfill liners. *5th International Landfill Symposium: Sardinia 95*, 2:437–452, 1995.
- [3] V. Nosko and N. TouzeFoltz. Liner failure: Modelling of its influence on contaminant transfer. *EuroGeo 2*, 2:557–560, 2000.
- [4] M. Marcotte A.L. Rollin and L. Chaput. Lessons learned from geo-electrical leaks surveys. *7th International Conference on Geosynthetics*, 2:527–530, 2002.
- [5] E. Kramer A. Beck and M. Smith. Specifications for moisture content of gcl to perform electrical leak location surveys. *EuroGeo 4*, page 279, 2008.
- [6] ASTM D7007-03. Standard practices for electrical methods for locating leaks in geomembranes covered with water or earth materials, 2003.
- [7] ThaiEasyElec. Blue screen user manual v1.00. Technical report, ThaiEasyElec, 2010.
- [8] Maxim Integrated Products. Max4460 - rail-to-rail instrumentation amplifiers. Technical report, Maxim, 2006.
- [9] Microchip. Mcp3201 - 2.7v 12-bit a/d converter with spi serial interface. Technical report, Microchip, 2007.
- [10] Vishay Semiconductors. Il74 / ild74 / ilq74 - optocoupler, phototransistor output. Technical report, Vishay Semiconductors, 2004.
- [11] Vishay Semiconductors. Lh1500aab - 1 form a solid state relay. Technical report, Vishay Semiconductors, 2011.